

Steam traps and steam specialty products for critical applications



Nicholson™ Steam Traps and Steam Specialty Products
Portfolio includes mechanical, orifice, thermostatic, thermodynamic, variable orifice and clean steam product designs in addition to condensate pumps, piping specialties and other accessories



Thermostatic Steam Trap

Applications

- Unit Heaters
- Laundry Equipment
- Steam Tracing
- Plating Tanks
- Drip Legs
- Platen Presses
- Tire Presses
- Cooking Equipment
- Air Vents

EASILY MAINTAINED

Four bolt cover permits easy in-line rebuilding for less than the cost of replacement.

EXCELLENT ENERGY SAVINGS

Positive shutoff and thermostatic action assure no loss of steam during normal operation.

FITS ALL UNIVERSAL CONNECTORS

Liquidator body will replace any manufacturers' universal mount trap body.

EASILY REPLACED

Two bolt design permits rapid removal without breaking pipe connections.

FREEZE PROOF

Self draining when installed vertically.

OPTIONAL INTEGRAL STRAINER

Helps prevent dirt and scale build-up on valve seat.

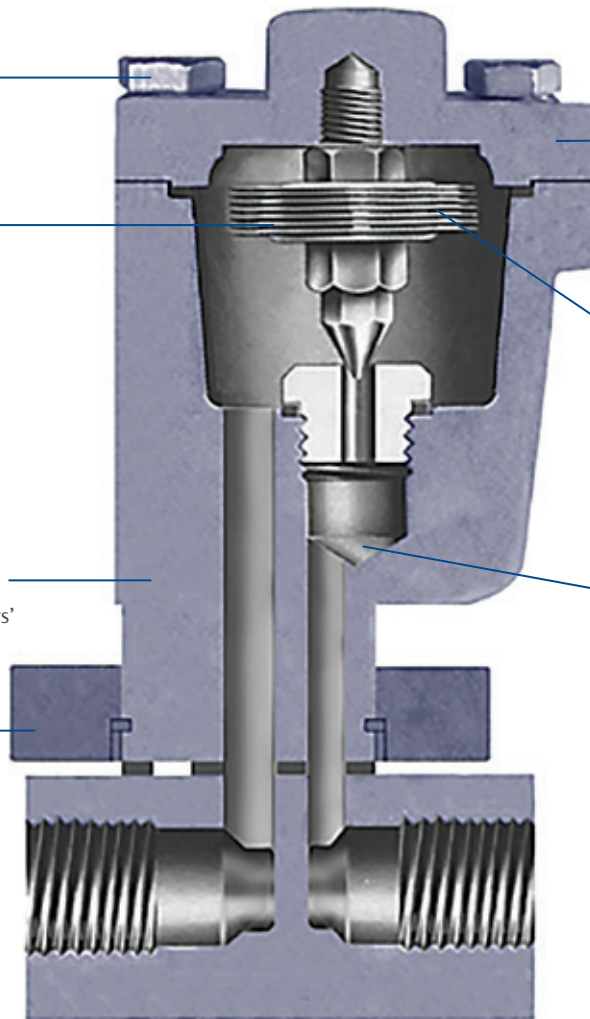

DURABILITY AND LONG SERVICE LIFE

Stainless steel body and cover with stainless steel welded actuator for maximum corrosion, thermal and hydraulic shock resistance.

RAPID STARTUP WITH OUTSTANDING AIR HANDLING

Thermostatic action responds quickly to eliminate air and other non-condensibles. Large startup capacity.

WATER TIGHT SEAL

Hardened stainless steel valve and seat lapped as a matched set assure tight seal and long life.

Thermostatic Traps

N125 and N25 Series

- Welded stainless steel bellows
- Repairable in-line
- Freezeproof
- For low-to-medium condensate tracing and process

- Pressures to 125 PSIG
- Temperatures to 400°F
- NPT 1/2" or 3/4"



N450 Series

- Welded stainless steel bellows
- Repairable in-line
- Freezeproof
- For process and for tracer and drip leg

- Pressures to 450 PSIG
- Temperatures to 600°F
- NPT or socket weld 1/2" or 3/4"



Liquidator 450 Series

- Universal two bolt swivel mount for simple installation
- Repairable in-line
- Freezeproof
- Welded stainless steel bellows

- For tracer, drip leg and medium process
- Pressures to 450 PSIG
- Temperatures to 600°F
- Mounting block in NPT or socket weld 1/2", 3/4", 1"



TA500 Series

- Welded stainless steel bellows
- 316L stainless steel body
- Maintenance free
- Freezeproof

- For tracer, drip leg and medium process
- Pressures to 650 PSIG
- Temperatures to 750°F
- NPT or socket weld 3/8", 1/2", 3/4", 1"



N650 Series

- Integral stainless steel strainer and blowdown valve
- Welded stainless steel bellows
- Repairable in-line
- Freezeproof

- For tracer, drip leg and process
- Pressures to 650 PSIG
- Temperatures to 750°F
- NPT or socket weld 1/2" or 3/4"



A Series

- Welded stainless steel bellows
- Repairable in-line
- Freezeproof
- For process equipment

- Pressures to 200 PSIG
- Temperatures to 400°F
- NPT 1/2" to 1"



B Series

- Welded stainless steel bellows
- Repairable in-line
- Freezeproof
- For unit and hot water heaters, coils, steam mains and large heat exchangers

- Pressures to 250 PSIG
- Temperatures to 450°F
- NPT 1/2" to 2"



C Series

- Welded stainless steel bellows
- Repairable in-line
- Freezeproof
- For unit and hot water heaters, coil, steam mains, dryers and large heat exchangers

- Pressures to 300 PSIG
- Temperatures to 500°F
- NPT or socket weld 1/2" to 2"
- Cast iron or cast steel body



Thermodynamic Steam Trap

Applications

- Unit Heaters
- Laundry Equipment
- Steam Tracing
- Plating Tanks
- Drip Legs
- Platen Presses
- Tire Presses
- Cooking Equipment

EASILY MAINTAINED

Four bolt cover permits easy in-line rebuilding for less than the cost of replacement.

OPTIONAL INTEGRAL STRAINER

Helps prevent dirt and scale buildup on valve seat.

EXCELLENT ENERGY SAVINGS

Positive shutoff assures no loss of steam during normal operation.

FITS ALL UNIVERSAL CONNECTORS

Liquidator body will replace any manufacturers' universal mount trap body.

EASILY REPLACED

Two bolt design permits rapid removal without breaking pipe connections.

FREEZE PROOF

Self draining when installed vertically.

DURABILITY AND LONG SERVICE LIFE

Stainless steel body and cover with stainless steel Celtron® Cartridge for maximum corrosion, thermal and hydraulic shock resistance.

UNAFFECTED BY AMBIENT CONDITIONS

Steam jacketing minimizes steam loss.

BLAST DISCHARGE

Clears away dirt and scale.

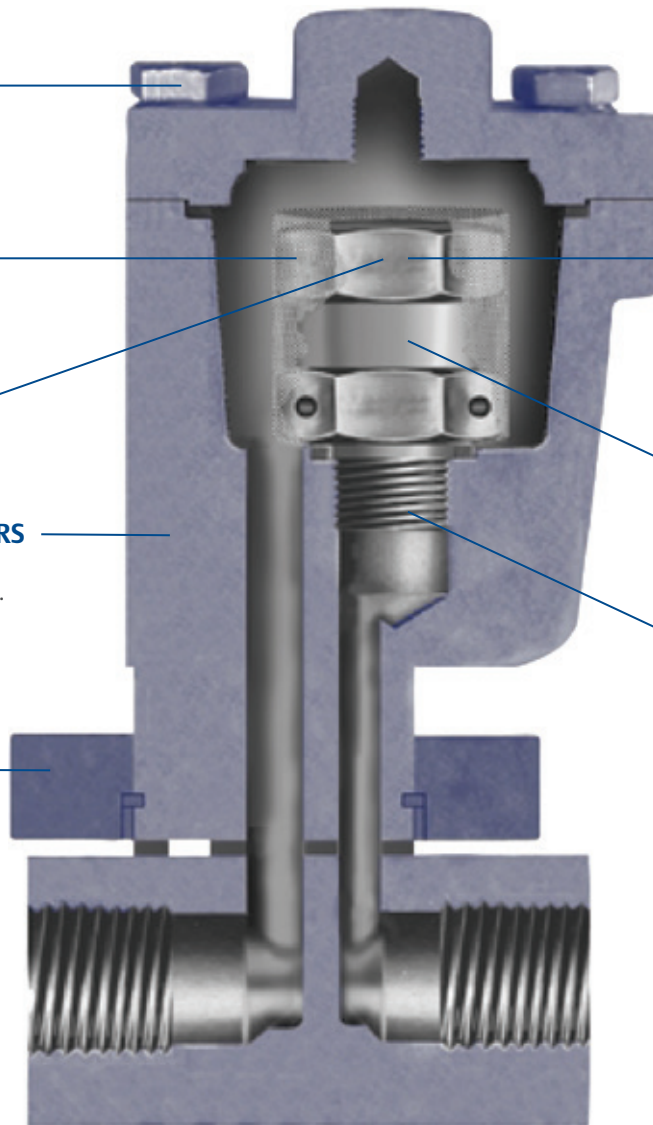

Thermodynamic Traps

NTD600 Series

- Conventional thermodynamic trap
- Optional strainer and/or blowdown valve
- All stainless steel construction
- Repairable in-line
- Freeze resistant

- For tracer and drip leg
- Pressures to 600 PSIG
- Temperatures to 800°F
- NPT or socket weld 3/8" to 1"



NTD600



NTD600B

Liquidator UMT-TD Series

- Universal two bolt swivel mount for simple installation
- Repairable in-line with Celtron® cartridge
- Freezeproof
- For tracer, drip leg and light process

- Pressures to 450 PSIG
- Temperatures to 650°F
- Mounting block in NPT or socket weld 1/2", 3/4", 1"



Inverted Bucket Steam Trap

Applications

- Steam Lines
- Unit Heaters
- Process Equipment
- Oil Preheaters
- Steam Cookers
- Converters
- Steam Heated Vats
- Coils
- Pressing Machinery
- Rotating Drum

EASY TO MAINTAIN

Working parts lift out with top for quick inspection and maintenance.

RESISTS CORROSION

Stainless steel bucket provides maximum service life with minimum deterioration.

MINIMIZES EFFECTS OF WATER HAMMER

Open bucket design avoids collapse typical of sealed floats.

SUITABLE FOR WIDE VARIETY OF LOADS/APPLICATIONS

Horizontal and vertical models in thirteen body sizes are one of the most comprehensive inverted bucket trap lines available.

WITHSTANDS SEVERE CONDITIONS

Heavy wall cast iron cover and body provide many years of trouble free service.

SMOOTH ACTION AND TIGHT SHUTOFF

Stainless steel linkage, valve and seats are precision manufactured to ensure optimal performance.

IDEAL FOR "DIRTY" SYSTEMS

Valve and seat located at top of trap and stainless steel strainers available on most horizontal models ensure long service

MAXIMUM COMPATIBILITY WITH EXISTING INSTALLATIONS

Pressure change assemblies are interchangeable with Armstrong which guarantees maximum flexibility when stocking repair parts.

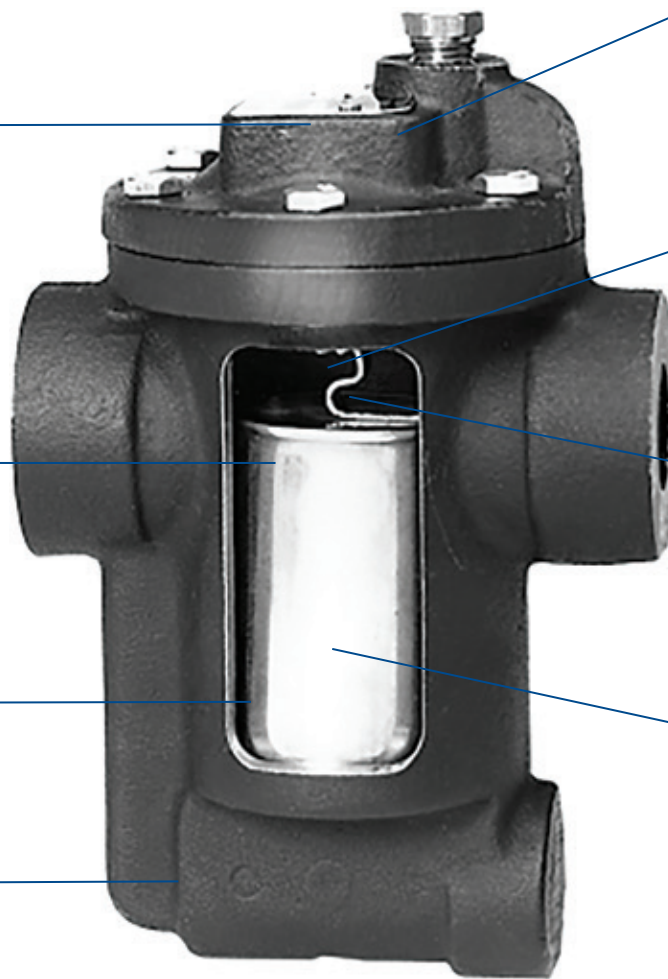

Inverted Bucket Traps

Dura-Flo Series

- Conventional inverted bucket trap
- Integral strainer
- All stainless steel internals
- Horizontal and vertical models
- Repairable in-line

- For drip leg and process
- Pressures to 250 PSIG
- Temperatures to 450°F
- NPT 1/2" to 2-1/2" in 13 body configurations



Horizontal Mount



Vertical Mount

Stainless Steel Dura-Flo

- NPT horizontal and Universal Mount inverted bucket trap
- Stainless Steel body and internals
- Inexpensive, low maintenance and disposable
- For drip leg and process applications
- Pressure to 650 PSIG

- Temperatures to 497°F
- NPT 1/2" to 1" in three body configurations
- Universal mount, two-bolt swivel connection, 1/2" to 1"



Horizontal Mount



Universal Mount

Variable Orifice Traps

Applications

- Steam Lines
- Unit Heaters
- Process Equipment
- Oil Preheaters
- Steam Cookers
- Converters
- Steam Heated Vats
- Coils
- Pressing Machinery
- Rotating Drum

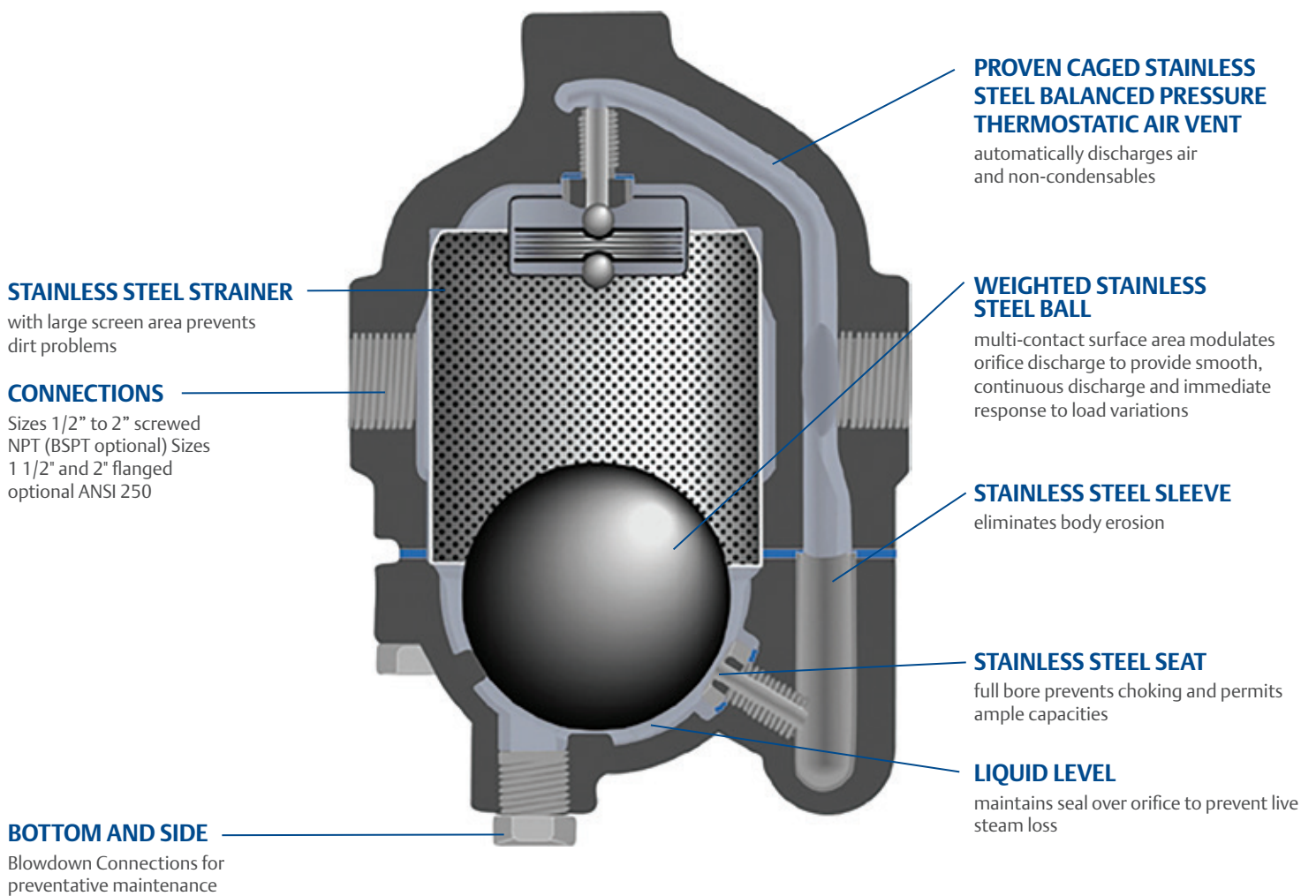

Variable Orifice Traps

Nova NFT250 Series

- No mechanical linkage
- Modulating continuous discharge
- All stainless steel internals including bellows, float and strainer
- Repairable in-line

- For heavy load process
- Pressures to 250 PSIG
- Temperatures to 450°F
- NPT or flanged 1/2" to 2"



Nova NFT650 Series

- No mechanical linkage
- Modulating continuous discharge
- All stainless steel internals including bellows, float and strainer
- Repairable in-line

- For heavy load process
- Pressures to 650 PSIG
- Temperatures to 750°F
- NPT, socket weld and flanged (#300, #600) 1/2" to 2"



Float and Thermostatic Traps

FTN Series

- Conventional F and T
- All stainless steel internals
- Universal four port design available
- Repairable in-line

- For process applications
- Pressures to 125 PSIG
- Temperatures to 450°F
- NPT 3/4" to 2"



FTN



FTN "H" Pattern

Max-Flo HC Series

- High capacity F and T
- All stainless steel internals
- Two port "C" configuration
- Repairable in-line

- For heavy load process
- Pressures to 175 PSIG
- Temperatures to 377°F
- NPT 1 1/4" to 2-1/2"



FTE In-Line Series

- In-line configuration F and T trap
- All Stainless Steel internals
- Cast iron, ductile iron or cast steel bodies and covers
- In-line repairable
- For process applications
- Pressure to 464 PSIG

- Temperatures to 850°F
- NPT, BSPT, DIN, socket weld, flanged and ANSI connections
- Sizes: 1/2" to 2"



FTE 10

FTE 44F

FTE 43

FTE 44

FTE 14

Condensate Pump

Applications

- Collection of condensate
- Where electrical service is unavailable
- Submerged or remote sumps and manholes
- Hazardous fluids and process fluids
- Low pressure and vacuum systems
- High back pressure systems
- High capacity process applications



UNIQUE SINGLE SPRING MECHANISM

Eliminates pump breakdown due to spring failure

Snap acting mechanism actuates the valve

Heavy duty spring operating in compression carries lifetime warranty

Unaffected by turbulence

Stainless steel construction maximizes reliability and service life

Valve and linkage positioning above condensate level minimizes

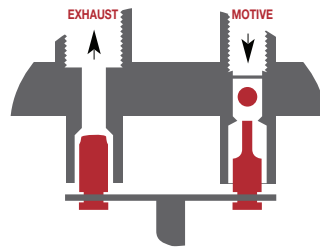

INLET SUPPLY AND VENT VALVES

Lapped valves and seats for tight shutoff
Stainless steel construction resists corrosion
Floating ball design and hardened sealing surface of supply valve provide long service life
Floating disk and ball valves feature an infinite number of seating surfaces
Self centering design assures reliable performance



CYCLE COUNTER

Accurately depicts number of cycles and assists in maintenance scheduling

RETROFIT MECHANISM AVAILABLE

Head assembly fits many manufacturer's tanks

ASME CODE STAMPED TANK

Fabricated steel tank is standard on most models

Condensate Pumps

Condensate Commander Pump

- Powered by steam or compressed gas
- ASME Code stamped tank
- All stainless steel snap acting mechanism retrofits many manufacturers' units
- For condensate pumping where electricity is impractical

- Pressures to 250 PSIG
- Temperatures to 650°F
- Capacities exceed 48,000 lbs/hr
- Vertical and horizontal models
- NPT or flanged 1" x 1" to 4" x 4"



Horizontal

Condensate Commander Skid System

- Standard system includes one or more pumps, receiver tank and all connections
- Customized systems to meet unique space and/or capacity requirements

- Prefabricated system facilitates quick installation
- Capacities exceed 200,000 lbs/hr



Gasketed Unions

Uniflex Union

- No leak seal equivalent to flange with ease of NPT connection
- Spiral wound gasket ensures a leak-tight seal
- For all process and industrial applications

- Pressures to 3000 PSIG
- Temperatures to 850°F
- NPT or socket weld 1/2" to 2"



Vacuum Breakers

Vacu-Break Series

- Improved System Efficiency
- Maintenance free
- Brass Body, Stainless Steel Spring EPDM Seat
- Cracking Pressure 0.36 PSIG

- Pressures to 125 PSIG
- Temperatures to 350°F
- NPT 1/8", 1/2" and 3/4" Sizes



Clean Steam

CDS Series

- 316L Stainless Steel Bellows
- Free draining, fail open
- Self centering conical valve
- Sanitary clamp for easy disassembly

- For CIP/SIP and sterilization
- Pressures to 100 PSIG
- Temperatures to 338°F
- Sanitary clamp 1/2" to 1 1/2"



CDH Series

- 316L Stainless Steel Bellows
- Free draining, fail open
- Swivel connections
- Self centering conical valve
- Sanitary clamp for easy disassembly

- For CIP/SIP and sterilization
- Pressures to 100 PSIG
- Temperatures to 338°F
- Sanitary clamp 1/2" and 3/4"



DS100 Series Steam Trap

- Welded 316L Stainless Steel Bellows
- Free draining, fail open
- Maintenance free
- For CIP/SIP and sterilization

- Pressures to 150 PSIG
- Temperatures to 366°F
- Sanitary clamp or tube 1/2" to 1"
- Optional check valve



Combo Condensate Measuring Elbow Sanitary Steam Trap

- CMV - Vertical configuration
- 6" Condensate Cooling Elbow
- CDS Series Steam Trap features

- 2 to 3°F Subcool
- Pressures to 40 PSIG
- Temperatures to 292°F



CMV

DS200 Series Steam Trap

- 316L Stainless Steel Bellows
- Self centering conical valve
- Free draining, fail open
- Maintenance free

- For drip leg and sterilization
- Pressures to 100 PSIG
- Temperatures to 338°F
- NPT 3/8" to 1"



NLD / NAV

- Effective removal of liquids from air or steam systems
- Effective positive venting of Air/Gas under pressure

- Pressures to 400 PSIG
- Temperatures to 500°F
- Loads to 2000 lb./hr
- NPT



NLD

NAV

Drain Orifice Traps

DFA

- Maintenance free, no moving parts
- Easy to install
- Freezeproof
- Resists thermal and hydraulic shock
- Spiral wound inlet strainer gasket with 60 mesh domed screen

- For ANSI B16.5 flange applications
- Pressures to 2500 PSIG
- Temperatures to 750°F
- For flanged 1/2" to 2"
- Meets MS 18301



DUA

- Maintenance free, no moving parts
- Easy to install
- Freezeproof
- Resists thermal and hydraulic shock

- Spiral wound inlet strainer gasket with 60 mesh domed screen
- Pressures to 3000 PSIG
- Temperatures to 850°F
- NPT or socket weld 1/2" to 1"



Piping Specialties

TAV Thermostatic Air Vent

- Removes air from steam systems
- Isopropyl filled stainless steel bellows
- 316L stainless steel body
- Maintenance free and freezeproof
- Pressures to 650 PSIG
- Temperatures to 750°F
- NPT or socket weld 3/8" to 1"



Mini-Drain and Drain Air

- Removes condensate from compressed air systems
- Compact, durable, lightweight
- Muffler reduces noise and diffuses moisture
- Pressures to 600 PSIG
- Temperatures to 220°F
- NPT 1/8" or 1/2"



Pneumatic Muffler

- Compact, durable, lightweight, non-corrosive
- Reduces noise levels to OSHA standards
- For exhaust air in pneumatic systems
- Pressures to 600 PSIG
- Temperatures to 220°F
- Male NPT 1/8" to 1/2"



STV Trap Test and Blocking Valve

- Provides for quick visual check of steam trap operation
- Bottom loaded stem and packing nut
- Compact body is easy to install
- Pressures to 250 PSIG
- Temperatures to 406°F
- NPT 1/2" and 3/4"
- Cast Steel or Stainless Steel with locking handles



SS600

- Diffuses High Velocity Discharge from Steam Traps
- Dampens the Level of Noise Associated with Steam Trap Discharge
- Porous Stainless Steel Baffle Allows Condensate Discharge Without Back Pressure
- NPT 3/8" to 3/4" – Stainless Steel Construction



UMTVS-BB "Big Block"

- Isolation valves, test ports, strainer and blowdown valve combined in one "Big Block" for easy installation
- Universal two bolt swivel trap mount installs permanently into system, simplifying installation and removal of trap
- Available with Inverted Bucket, Thermodynamic or Thermostatic Trap
- Pressures to 1440 PSI
- Temperatures to 750°F





Notes

Nicholson™ steam traps and steam specialty products



Emerson Automation Solutions

Americas

McKinney, Texas 75070 USA
T +1 972 548 3574

Walden, NY 12586 USA
T +1 845 778 5566

Europe

T +39 051 419 0611

Asia Pacific

T +65 6777 8211

Middle East / Africa

T +971 4811 8100

✉ webadmin.regulators@emerson.com
🔍 SpenceEngineering.com

D353009X012 © 2019 Emerson Process Management Regulator Technologies, Inc. All rights reserved. 11/19.
Nicholson is a mark owned by one of the companies in the Emerson Automation Solutions business unit of Emerson Electric Co.
The Emerson logo is a trademark and service mark of Emerson Electric Co. All other marks are property of their respective owners.



CONSIDER IT SOLVED.™