

November 2021

# Spence™ T61 Series Pneumatic Temperature Controller



*Figure 1. T61 Series Pneumatic Temperature Controller*

## Features

- **Bimetallic Thermostat for Fast Response**
- **Pinpoint Accuracy**
- **Over temperature Protection**

## Introduction

The T61 Series Temperature Controller is ideal for wide ranging, fast changing loads on instantaneous heaters and other difficult process applications. The cascade principle, normally used only on instrument type regulators, is the basis for this design.

T61 Series, used with a properly selected A Series Pilot or Control Valve, continuously adjusts a pressure regulator to the required heater pressure. This action, coupled with the fast response of a bimetallic thermostat, gives exceptional results. Added convenience and economy results from the wide (200°F / 93°C) adjustable range and the low air consumption (0.35 cfm / 0.59 m<sup>3</sup>/h). These controllers have adjustable proportional band as well as over temperature protection.

# T61 Series

## Specifications

The Specifications section gives some general specifications for the T61 Series pneumatic temperature controller. The nameplates give detailed information for a specific controller as built in the factory.

### Available Configurations<sup>(1)</sup>

**Type T61:** Reverse Acting

### Maximum Air Supply

30 psi / 2.07 bar

### Maximum Signal Pressure

2 psi / 0.14 bar below supply

### Maximum Inlet Pressure<sup>(2)</sup>

250 psi / 17.2 bar

### Maximum Inlet Temperature<sup>(2)</sup>

400°F / 204°C

### Temperature Ranges<sup>(2)</sup>

50 to 250°F / 10 to 121°C

### Mounting

1/2 NPT

### Air Connections

1/8 NPT

### Air Consumption

**Normal:** 0.35 SCFM / 0.59 m<sup>3</sup>/hr

**Maximum:** 0.70 SCFM / 1.19 m<sup>3</sup>/hr

### Proportional Band Adjustable

1/4 to 2 psi per 1°F / 0.02 to 0.14 bar per 17.2°C

### Construction Materials

**Body:** Bronze

**Seal:** Viton®

**Spool:** Brass

**Seat and Spring:** Stainless steel

**Thermostat bulb:** Bronze or stainless steel

### Application

Instantaneous Heaters

Process Applications with wide range and fast changing loads

### Approximate Weight

2-3/4 lbs / 0.68 kg

1. Reverse Acting is when air control signal decreases as process temperature increases. Direct Acting is when air control signal increases as process temperature increases.  
2. The pressure/temperature limits in this Bulletin or any applicable standard limitation should not be exceeded.

## Principle of Operation

### When Used with Regulator

The regulator is operated by its initial steam pressure. It is normally closed, being held so by initial pressure on the disc and by an internal main spring. The pressure pilot is actuated by means of an air signal applied to its diaphragm. This signal is received from the temperature pilot as a result of the temperature bulb sensing a drop in temperature from the control setting.

When steam is turned on, it flows through the pressure pilot (Figure 3) to No. 8B tee. Bleedport No. 4A restricts the flow, builds pressure under the diaphragm and opens the main valve. Restriction No. 5A steadies the operation of the regulator.

Steam flowing to the heater develops a rising delivery pressure which feeds back through the control pipe to the pressure pilot diaphragm. As this pressure approached a balance with the air pressure signal supplied by the temperature pilot, the pressure pilot throttles. This, in turn, allows the main valve to assume a position to maintain the set temperature.

As the temperature at the outlet of the heater increases, it causes the T61 Series controller to reduce the loading pressure and this, in turn, will cause the pressure regulator to modulate the steam flow to the heater.

### When Used with Pneumatic Control Valve

The T61 Series controller sends a proportional air signal from 0 psi / 0 bar to a maximum of 30 psi / 2.07 bar (not greater than 2 psi / 0.14 bar less than the supplied pressure) within a 10 degree span. The pilot will increase signal as the temperature falls, which will either open or close the control valve, depending upon actuator configuration.

## Installation

### Planning

1. Locate the regulator in a horizontal pipe. Provide a trap ahead of the regulator to prevent water hammer and erratic operation.
2. Use a strainer to avoid damaging effects of scale and dirt in pipelines to protect the regulator.
3. Provide a three valve bypass to facilitate inspection of the regulator without interrupting service.

Viton® is a mark owned by E.I. du Pont de Nemours and Co.



# T61 Series

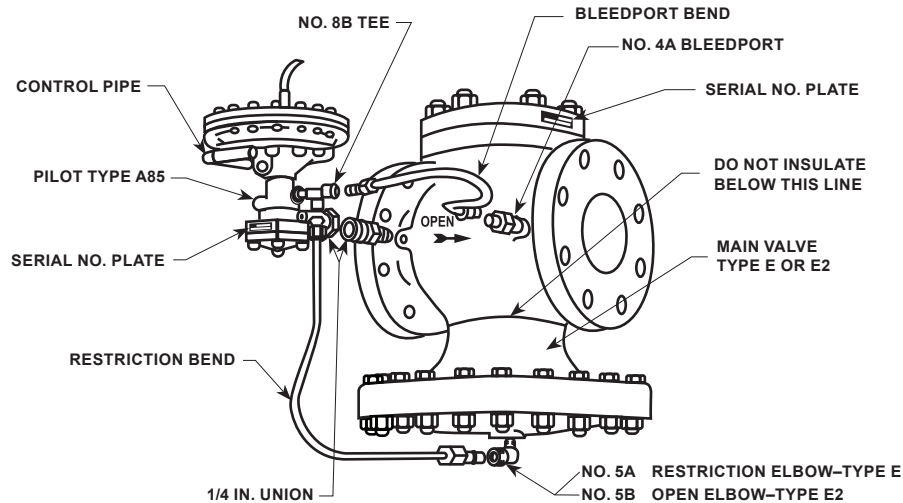
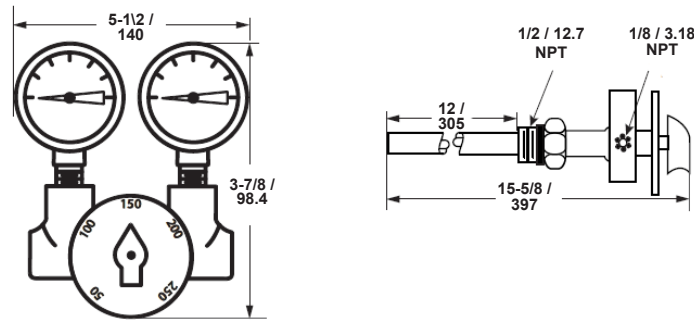

Figure 3. T61 Series Tubing Bends Connection



IN. / mm.

## T61 SERIES CONTROLLER

Figure 4. T61 Series Dimension

 SpenceValve.com

### Emerson

**Americas**  
McKinney, Texas 75069 USA  
T +1 800 558 5853  
+1 972 548 3574

**Europe**  
Bologna 40013, Italy  
T +39 051 419 0611

**Asia Pacific**  
Singapore 128461, Singapore  
T +65 6777 8211

**Middle East and Africa**  
Dubai, United Arab Emirates  
T +971 4 811 8100

VCIMD-16353 © 2021, 2026 Emerson Electric Co. All rights reserved 03/26.  
Spence is a mark owned by a subsidiary of Emerson Electric Co. The Emerson logo is a trademark and service mark of Emerson Electric Co. All other marks are property of their respective owners.

Neither Emerson nor any of its affiliated entities assume responsibility for the selection, use or maintenance of any product. Responsibility for proper selection, use, and maintenance of any product remains solely with the purchaser and end user.

The contents of this publication are presented for informational purposes only, and while every effort has been made to ensure their accuracy, they are not to be construed as warranties or guarantees, express or implied, regarding the products or services described herein or their use or applicability. All sales are governed by our terms and conditions, which are available upon request. We reserve the right to modify or improve the designs or specifications of such products at any time without notice.

