

March 2021

Spence Q Series Back Pressure Pilots

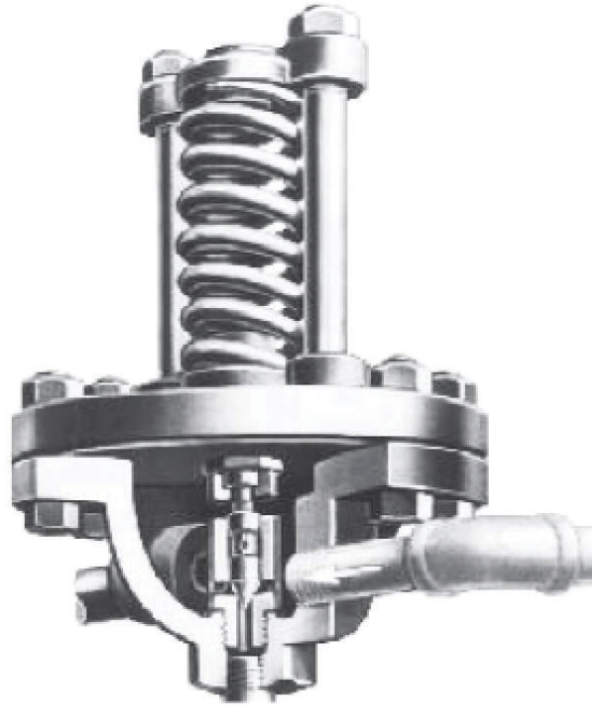

Figure 1. Q Series Pilots

Features

- Spring Operated
- Packless Construction
- Adjustable Spring Ranges
- Fluid, Gas and Vapor Applications
- Loading Pressure Supplied by any Fluid
- Accurate Regulation Unaffected by Service Conditions
- Easy In-line Maintenance

Introduction

The Q Series pilot is separated from the main valve and connected to it with a male union. It is normally closed, designed with packless construction and interchangeable on all sizes of main valves. A strainer screen is built into the pilot inlet.

These regulators are designed to maintain a constant back pressure by discharging excess flow to a lower system pressure or atmosphere.

A back pressure regulator is not a safety valve and should never be used as such.

Q Series

Specifications

The Specifications section gives some general specifications for the Q Series pilots. The nameplates give detailed information for a specific pilot as built in the factory.

<p>Available Configurations See Table 1</p> <p>Body Size and End Connection Style 1/4 NPT</p> <p>Maximum Inlet Pressure⁽¹⁾ Cast iron: 250 psig / 17.2 bar Cast steel: 600 psig / 41.4 bar</p> <p>Maximum Inlet Temperature⁽¹⁾ Cast Iron: 450°F / 232°C Cast Steel: 750°F / 400°C</p> <p>Outlet Pressure Ranges</p> <p>Types Q and Q73: 3 to 20 psig / 0.21 to 1.38 bar 5 to 50 psig / 0.35 to 3.45 bar 10 to 100 psig / 0.69 to 6.90 bar 20 to 150 psig / 1.38 to 10.3 bar</p> <p>Type Q2: 100 to 300 psig / 6.90 to 20.7 bar</p>	<p>Construction Materials Body: Cast iron and Cast steel Disk, Seat and Diaphragm: Stainless steel Spring: Steel</p> <p>Option Enclosed Spring Chamber Adjusting Handle High Pressure</p> <p>Application Pump Bypass Maintain Upstream Pressure in Steam and Liquid Distribution Systems</p> <p>Approximate Weights Type Q: 7 lbs / 3.2 kg Type Q2: 10 lbs / 4.5 kg Type Q73: 15 lbs / 6.8 kg</p>
--	---

1. The pressure/temperature limits in this Bulletin and any applicable standard or code limitation should not be exceeded.

Table 1. Q Series Available Configurations

TYPE	APPLICATION
Q	For ± 1 psig / 0.07 bar accuracy controlling backpressures between 3 and 150 psig / 0.21 to 10.3 bar
Q2	For ± 2 psig / 0.14 bar accuracy controlling backpressures between 100 and 300 psig / 6.89 to 20.7 bar
Q73	Air adjusted for ± 1 psig / 0.07 bar accuracy controlling backpressure at high retained pressures when available loading air is at low pressure. Delivery to loading pressure is 6-2/3 to 1 psig / 0.28 to 0.07 bar

Principle of Operation

The main valve is normally closed. Backpressure regulator responds to changes in upstream pressure. Pressure changes register to the pilot diaphragm through a control line. If the upstream pressure increases, the pilot opens and fluid starts to fill the connecting tubing. Orifice coupling (No. 4A bleedport) restricts flow and builds pressure under the main valve diaphragm, opening the main valve. Opening of the main valve relieves pressure in inlet pipe and control line, relaxing pressure on the pilot diaphragm. As pressure at the pilot diaphragm approaches a balance with control spring force, the regulator is under throttling operation. Once the pressure at pilot is less than the force of the control spring, the pilot closes and allows the main valve to close until an increase in backpressure occurs.

Installation

1. Mount the Q Series pilot on either side of the main valve using the 1/4 in. / 6.35 mm blind nipple and union provided.
2. Install the provided fittings in their proper locations. These fittings are vital to the operation of the regulator and must be properly installed and unobstructed.
3. Install a 1/2 in. / 12.7 mm control pipe with gate valve to connect the pilot to the selected control point in the backpressure pipe. The control pipe transmits the backpressure signal to the pilot and also provides the small amount of fluid required to operate the main valve. The control pipe should be as short as practical and must connect to the backpressure pipe at a point of minimum turbulence.

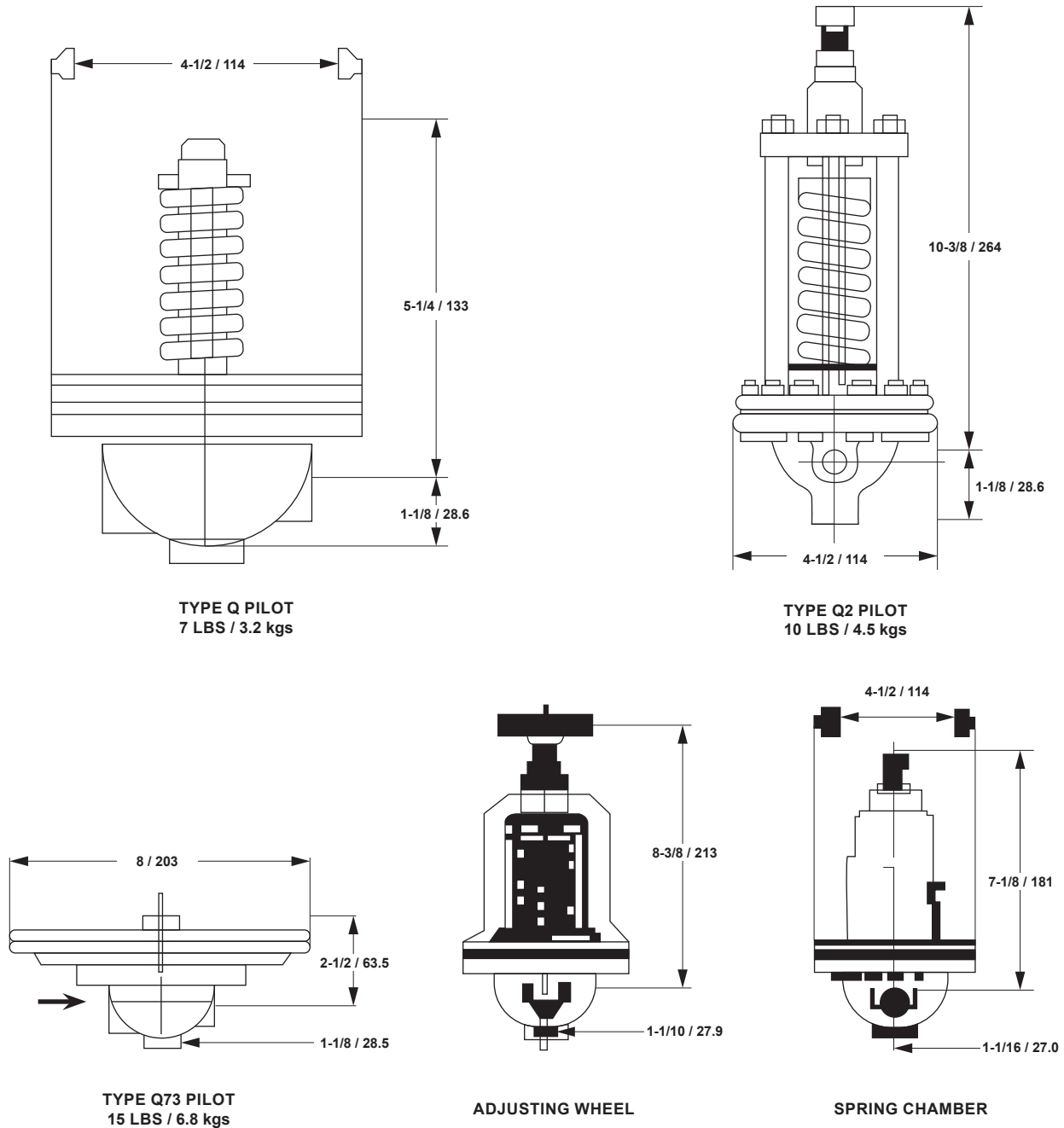

IN. / mm

Figure 2. Q Series Pilots Dimension

Note

Avoid selecting a control point near a turn or enlargement in pipe size. On steam service, install the control pipe so that a water leg or pocket will not occur. If necessary, install a float and thermostatic trap for drainage.

- Insulation may be applied to the upper portion of the main valve (globe and flange). Do not insulate the diaphragm chamber, condensation chamber (if supplied) or any part of the pilot.

Q Series

Ordering Information

When ordering, complete the ordering guide on this page. Refer to the Specifications section. Review the description to the right of each specification and the

information in each referenced table or figure. Specify your choice whenever a selection is offered.

Ordering Guide

Available Configurations (Select One)

- Type Q
- Type Q2
- Type Q73

Body Material (Select One)

- Cast iron
- Cast steel

Pressure Ranges (Select One)

- 3 to 20 psig / 0.21 to 1.38 bar
- 5 to 50 psig / 0.35 to 3.45 bar
- 10 to 100 psig / 0.69 to 6.90 bar
- 20 to 150 psig / 1.38 to 10.3 bar
- 100 to 300 psig / 6.9 to 20.7 bar

Options

- Enclosed Spring Chamber
- Adjusting Handle
- High Pressure

 [SpenceEngineering.com](https://www.spenceengineering.com)

 Sales@SpenceEngineering.com

Emerson Automation Solutions

Americas

McKinney, Texas 75070 USA
T +1 800 558 5853
+1 972 548 3574

Walden, NY
T +1 845 778 5566

Europe

Bologna 40013, Italy
T +39 051 419 0611

Asia Pacific

Singapore 128461, Singapore
T +65 6777 8211

Middle East and Africa

Dubai, United Arab Emirates
T +971 4 811 8100

VCBUL-16334 © 2021 Emerson Electric Co. All rights reserved 03/21. Spence and Nicholson are marks owned by one of the companies in the Emerson Automation Solutions business unit of Emerson Electric Co. The Emerson logo is a trademark and service mark of Emerson Electric Co. All other marks are property of their prospective owners.

The contents of this publication are presented for informational purposes only, and while every effort has been made to ensure their accuracy, they are not to be construed as warranties or guarantees, express or implied, regarding the products or services described herein or their use or applicability. All sales are governed by our terms and conditions, which are available upon request. We reserve the right to modify or improve the designs or specifications of such products at any time without notice.

Emerson Electric Co. does not assume responsibility for the selection, use or maintenance of any product. Responsibility for proper selection, use and maintenance of any Emerson Electric Co. product remains solely with the purchaser.

