

November 2021

# Spence™ NTD600 Series Thermodynamic Steam Trap



Figure 1. NTD600 Series Thermodynamic Steam Trap

## Introduction

The NTD600 Series is a thermodynamic design steam trap. Body is an all stainless construction and hardened throughout. Seat is integral to body. Cover seals to body without gaskets or seals. Trap is suitable for pressures through 600 psi / 41.3 bar and available in NPS 3/8 to 1 / DN 10 to 25.

## Features

- **Compact Design** - Hardened stainless steel disk is the only moving part.
- **Inexpensive** - Low initial cost is less expensive than repairable technologies.
- **Simplifies Installation** - Works in vertical or horizontal position.
- **Rugged** - Handles water hammer and superheat.
- **Reliable, Efficient Operation** - Blast discharge helps to eliminate dirt buildup and provides tight shutoff.
- **Freeze Resistant** - Self draining design prevents freezing.
- **All Stainless Steel Construction** - Resists both internal and external corrosion.
- **Easy to Monitor** - Audible discharge cycle makes checking operation simple.

# NTD600 Series

## Specifications

The specifications section on this page provides the ratings and other specifications for the NTD600 Series.

### Available Configurations

**Type NTD600:** Thermodynamic Disk Trap

**Type NTD600S:** Type NTD600 with integral strainer

**Type NTD600B:** Type NTD600S with blowdown valve

### Pressure Range<sup>(1)</sup>

2 to 600 psig / 0.14 to 41.3 barg

### Maximum Operating Pressure<sup>(1)</sup>

600 psig / 41.3 barg

### Maximum Operating Temperature<sup>(1)</sup>

800°F / 426°C

### Maximum Allowable Pressure<sup>(1)</sup>

600 psig / 41.3 barg

### Maximum Allowable Temperature<sup>(1)</sup>

800°F / 426°C

### Maximum Capacity

See Tables 1 and 2

### Materials of Construction

**Body:** 420F Stainless steel

**Cap and Disk:** 416 Stainless steel

**Blowdown Valve:** 304/316 Stainless steel

**Screen:** Stainless steel

### Approximate Weights

0.8 to 3.1 lbs / 0.36 to 1.8 kg

1. The pressure/temperature limits in this Bulletin and any applicable standard or code limitation should not be exceeded.

## Principle of Operation

Incoming air and condensate flow through the trap body and into the control chamber. Line pressure raises the disk off the seat allowing complete discharge. When flashing condensate enters the cartridge, flow velocity increases, creating low pressure underneath the disk. Flashing condensate at high velocity strikes the inside wall of the disk chamber and is deflected to the top of the disk causing a pressure buildup. The disk is forced down onto the seat by this pressure imbalance. The trap remains closed as flashed vapor in the control chamber keeps the disk seated. Pressure inside the cap is not lowered until the trapped flash vapor condenses due to body radiation. Condensing steam lowers the pressure above the disk. Disk is then lifted and the cycle repeated.

## Installation

1. Before installing trap, blow all dirt and scale from apparatus and piping.
2. Install trap with arrow on body in flow line as close as possible to apparatus with strainer and valve upstream of trap.
3. Pitch all drain lines toward trap.

### Note

**Approved practice is to install separate traps on each piece of apparatus to be drained. Steam supplied to inlets of several units may be of uniform pressure, but invariably there is a differential at the outlets. Although this differential may be small, unit discharging highest pressure will control the action of trap, while other units become air-bound and waterlogged.**

**Piping upstream and downstream of trap should be at least equal to or one size larger than trap connection.**

4. Retighten cap screws of all socket weld traps after field or shop welding.
5. Record the location of the trap for maintenance accessibility.

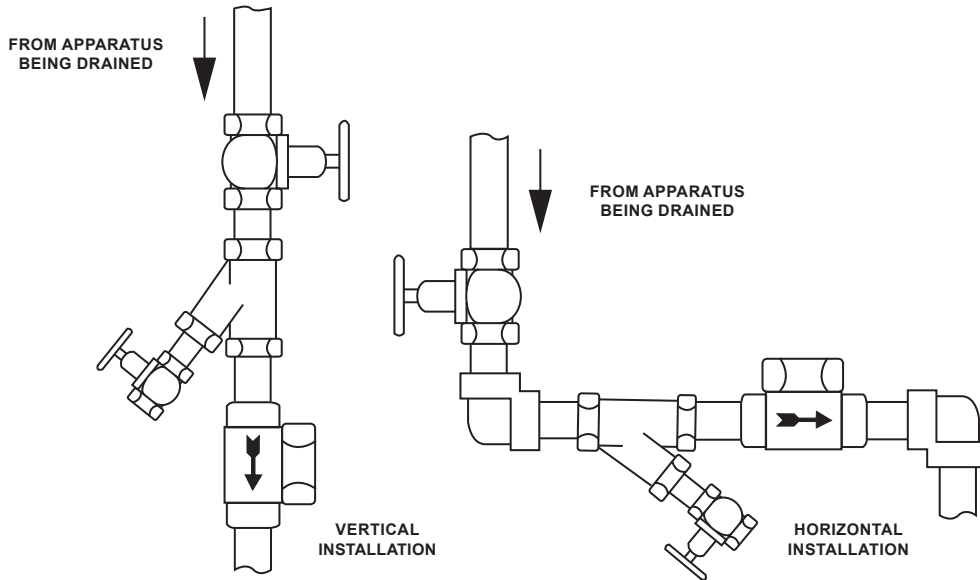

**Figure 2.** NTD600 Series Dimension

**Table 1.** NTD600 Series Maximum Capacities in lbs/hr 10°F Below Saturation, psi

SIZE		DIFFERENTIAL PRESSURE													
NPS	DN	3.5	5	10	20	30	50	75	100	150	200	300	400	500	600
3/8	10	180	185	190	200	215	245	305	370	500	610	790	960	1100	1250
1/2	15	300	310	345	410	465	575	700	810	1000	1140	1410	1630	1830	2000
3/4	20	405	420	410	560	640	810	1000	1160	1450	1670	2100	2430	2750	3050
1	25	640	670	725	865	980	1200	1470	1750	2200	2600	3250	3780	4250	4700

**Table 2.** NTD600 Series Maximum Capacities in kg/hr 5°C Below Saturation, bar

SIZE		DIFFERENTIAL PRESSURE													
NPS	DN	0.24	0.34	0.7	1.4	2.1	3.4	5.2	6.9	10.3	13.8	20.7	27.6	34.5	41.3
3/8	10	81.6	83.9	86.2	90.7	97.5	111	138	168	227	277	358	435	499	567
1/2	15	136	141	156	186	211	261	318	367	454	517	640	739	830	907
3/4	20	184	191	186	254	290	367	454	526	658	758	953	1102	1247	1383
1	25	290	304	329	392	445	544	667	794	998	1179	1474	1715	1928	2132

## Capacity

The NTD600 Series steam trap works efficiently at all line pressures between 2 and 600 psi / 0.14 and 41.3 bar and back pressures to 80% of line pressure.

## Ordering Information

When ordering, complete the ordering guide on this page. Refer to the Specifications section. Review the description to the right of each specification and the information in each referenced table or figure. Specify your choice whenever a selection is offered.

## Ordering Guide

**Available Configuration (Select One)**

- Type NTD600
- Type NTD600S
- Type NTD600B

# NTD600 Series

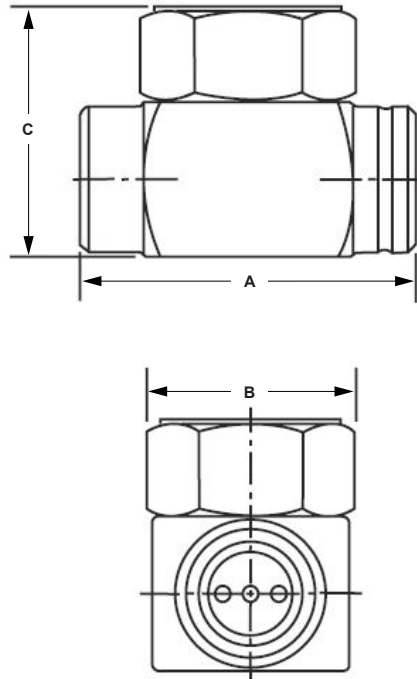

IN. / mm

Figure 3. NTD600 Series Dimension

Table 3. NTD600 Series Dimensions

SIZE		A		B		C		WEIGHT	
NPS	DN	In.	mm	In.	mm	In.	mm	lbs	kg
3/8	10	2	51	1-3/4	44	1-3/4	44	0.8	0.36
1/2	15	2	68	1-3/4	44	2	51	1.2	0.55
3/4	20	2-13/16	71	2-5/16	59	2-7/16	62	1.85	0.86
1	25	3-5/16	84	2-1/2	64	2-7/8	73	3.1	1.8

 SpenceValve.com

## Emerson

### Americas

McKinney, Texas 75069 USA  
T +1 800 558 5853  
+1 972 548 3574

### Europe

Bologna 40013, Italy  
T +39 051 419 0611

### Asia Pacific

Singapore 128461, Singapore  
T +65 6777 8211

### Middle East and Africa

Dubai, United Arab Emirates  
T +971 4 811 8100

VCBUL-15802 © 2021, 2026 Emerson Electric Co. All rights reserved 03/26.  
Spence is a mark owned by a subsidiary of Emerson Electric Co. The Emerson logo is a trademark and service mark of Emerson Electric Co. All other marks are property of their respective owners.

Neither Emerson nor any of its affiliated entities assume responsibility for the selection, use or maintenance of any product. Responsibility for proper selection, use, and maintenance of any product remains solely with the purchaser and end user.

The contents of this publication are presented for informational purposes only, and while every effort has been made to ensure their accuracy, they are not to be construed as warranties or guarantees, express or implied, regarding the products or services described herein or their use or applicability. All sales are governed by our terms and conditions, which are available upon request. We reserve the right to modify or improve the designs or specifications of such products at any time without notice.

