

November 2021

Spence™ ET124 and ET134 Series Integrally-Mounted Temperature Regulators



WARNING

Failure to follow these instructions or to properly install and maintain this equipment could result property damage and personal injury or death.

ET124 and ET134 Series regulators must be installed, operated and maintained in accordance with federal, state and local codes, rules and regulations and Emerson Process Management Regulator Technologies, Inc. instructions.

If the valve vents gas or a leak develops in the system, service to the unit may be required. Failure to correct issue could result in a hazardous condition.

Installation, operation and maintenance procedures performed by unqualified personnel may result in improper adjustment and unsafe operation. Either condition may result in equipment damage or personal injury. Only a qualified person shall install or service the ET124 and ET134 Series regulators.



Figure 1. ET124 or ET134 Series Regulator

Introduction

Scope of the Manual

This manual provides instructions for the installation, troubleshooting, maintenance, valve setting and parts ordering for ET124 and ET134 Series regulators. Refer to the following documents for the complete details.

- VCIMD-14980 for Types T124 and T134 temperature and pressure pilots.
- VCIMD-14961 for Type E main valve.
- VCIMD-14935 for Type E2 main valve.

Product Description

ET124 and ET134 Series are steam pressure reducing valves and temperature regulators in a single pilot-operated valve. These regulators are combination of Type T124 or T134 pressure and temperature pilot and a Type E or E2 main valve. Steam pressure on the heater is modulated in proportion to temperature and load variations. Pressure control provides fast, accurate adjustment of heat transfer rate to demand requirements.

ET124 and ET134 Series

Specifications

This section lists the specifications for the ET124 and ET134 Series. Factory specifications are stamped on the nameplate fastened on the regulator at the factory.

Available Configurations

Type ET124: For heater operating pressures between 20 to 125 psi / 1.38 to 8.62 bar.

Type ET134: For heater operating pressures up to 20 psi / 1.38 bar.

Type E2T134: For heater operating pressures up to 15 psi / 1.03 bar.

Sizes

NPS 3/8, 1/2, 3/4, 1, 1-1/4, 1-1/2, 2, 2-1/2, 3, 4, 5, 6, 8, 10, 12 / DN 10, 15, 20, 25, 32, 40, 50, 65, 80, 100, 125, 150, 200, 250 and 300

End Connection Styles

NPT

Maximum Operating Temperature⁽¹⁾

Type T124

Cast Iron: 450°F / 232°C

Type T134

Cast Steel: 750°F / 400°C

Cast Iron: 450°F / 232°C

Maximum Inlet Pressure⁽¹⁾

Type T124

Cast Iron: 250 psi / 17.2 bar

Type T134

Cast Steel: 600 psi / 41.4 bar

Cast Iron: 250 psi / 17.2 bar

Temperature Ranges⁽¹⁾

20 to 120°F / -7 to 49°C

50 to 150°F / 10 to 66°C

70 to 170°F / 21 to 77°C

120 to 220°F / 49 to 104°C

150 to 300°F / 66 to 149°C

170 to 270°F / 77 to 132°C

250 to 350°F / 121 to 177°C

Main Valve Material

Body: Cast Iron and Cast Steel

Stem, Disc, Seat: 416 Stainless steel

Gasket: Graphite

Diaphragm: 301 Stainless steel

Spring: Steel

Options

Bronze or Stainless steel Thermostat

Thermostat Well

Dial Thermometer

Tubing from 5 to 20 ft / 1.5 to 6.1 m

Integral Mount

1. The pressure/temperature limits in this Instruction Manual and any applicable standard or code limitation should not be exceeded.

Intended Purpose

The ET124 and ET134 Series temperature regulators are designed to reduce steam pressure and regulate the flow of steam to heater to control the temperature. No separate reducing valve is required. The heater pressure is automatically limited to the pressure limit spring setting. The Type ET134 has an adjustable range between 5 to 30 psi / 0.34 to 2.07 bar. The Type ET214 has an adjustable range between 20 to 125 psi / 1.38 to 8.62 bar. Slight variations at the thermostat throttle the steam pressure according to the demand for heat.

Principle of Operation

The regulator is operated by its initial steam pressure. The main valve is normally closed, being held so by initial pressure on the disk and by an internal main spring. The pilot is opened by compressing the pressure limit spring.

When steam is turned on, it flows to the pilot up through the top flange. See Figure 2. At the No. 8B tee between the valve and the pilot the flow divides, one branch being connected to bleedport No. 211, the other to restriction elbow No. 211, the other to restriction elbow No. 5A and the underside of the main valve diaphragm. Bleedport No. 211 restricts the flow, builds pressure under the diaphragm and opens the main valve. Restriction No. 5A steadies the operation

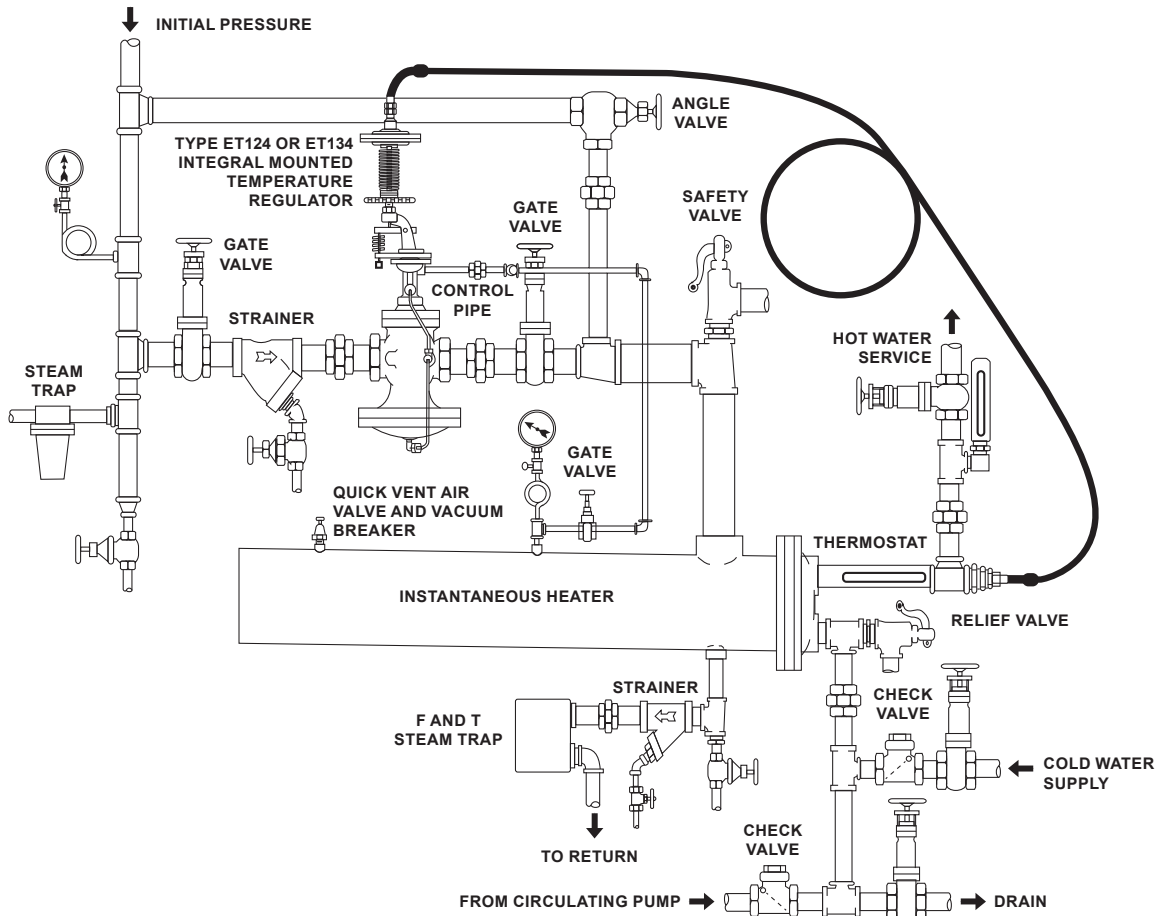

Figure 2. Recommended Installation of a Type ET124 or ET134 Integral Pilot Temperature Regulator on an Instantaneous Heater

of the regulator. Steam flowing to the heater creates a rising delivery pressure which feeds back through the control pipe to the underside of the pilot diaphragm. As the pressure on this diaphragm approaches a balance with the thrust of the pressure limit spring, the pilot throttles. This in turn, allows the main valve to assume a position where just enough steam flows to maintain the set maximum delivery pressure.

As the temperature of the heated medium rises, vapor pressure is generated in the thermostat bulb and transmitted to the pilot temperature diaphragm. When the vapor pressure becomes sufficient to over-balance the combined thrust of the temperature adjusting and pressure limit springs, the regulator throttles to maintain the set temperature.

Installation



WARNING

Personal injury or system damage may result if this regulator is installed, without appropriate overpressure protection, where service conditions could exceed the limits given in the Specifications section and/or regulator nameplate.

Additionally, physical damage to the regulator may result in personal injury or property damage due to escaping of accumulated gas. To avoid such injury and damage, install the regulator in a safe location.

Under enclosed conditions or indoors, escaping gas may accumulate and be an explosion hazard. In this case, the vent should be piped outdoors.

ET124 and ET134 Series

Planning the Installation

1. Locate the regulator in a horizontal pipe.
2. Prevent water hammer and erratic operation by providing a trap *ahead* of the regulator.
3. Avoid damaging the effects of scale and dirt in pipe lines by using a strainer to protect the regulator.
4. Provide a three-valve by-pass to facilitate inspection of the regulator without interrupting service.
5. Thermostat position:
 - a. The preferred thermostat position is horizontal.
 - b. When vertical or slanting, the tip of the bulb must point downward.
 - c. Locate the thermostat as close to the heater outlet as practical.
 - d. Expose the entire length of the bulb to the active flow leaving the heater.
6. If the pressure rating of the heater or the connected equipment is less than the initial stream pressure, provide a safety valve.
7. Hot water and similar liquid systems require a relief valve to prevent dangerous overpressure due to expansion.
8. Instantaneous Heaters - When operated on intermittent demand, as in domestic water heating, require the following conditions for best temperature regulation.
 - a. Constant forced recirculation of fluid through the heater.
 - b. Omission of thermostat well to reduce temperature lag. Use of a thermostat compatible with the heated medium is preferred over the use of a standard thermostat installed in a well, which is compatible with the heated medium. When the use of a well is unavoidable, an appropriate heat transfer medium should be installed between the well and the thermostat.

Main Valve

1. Flush the piping system thoroughly to clear it of welding beads, scale, sand, etc.
2. Mount the main valve with the diaphragm chamber down and arrow on body pointing in the direction of the flow.

Pilot

1. Remove the protecting cover from the top flange of the valve and flange of the pilot. Mount the pilot to the valve as shown in Figure 3.
2. Screw No. 4A bleedport fitting into the 1/8 in. / 3.18 mm pipe tap on the outlet side of the main valve body. Note that the bleed orifice in this fitting is vital to the operation of the regulator.
3. Screw No. 4B coupling into 1/8 in. / 3.18 mm pipe tap in pilot.
4. Screw No. 5A elbow containing the restriction orifice into the 1/8 in. / 3.18 mm pipe tap on the underside of the main valve diaphragm chamber. Type E2 main valves use a No. 5B elbow without orifice.
5. Connect the tubing bends as illustrated in Figure 3 for Type E and E2 main valves.

Control Pipe

1. Use 1/4 in. / 6.35 mm pipe for this line which connects the pilot pressure diaphragm chamber to the desired point of pressure control. See Figure 3.
2. On instantaneous heaters with steam in shell, tap the control pipe into the shell. Otherwise, enter the delivery steam pipe at point of entrance to the heater. (See Figure 2)
3. Pitch the control pipe away from the pilot and avoid water pockets.

Insulation

Insulation may be applied to the upper portion (globe and flanges) of the main valve. Do not insulate the diaphragm chamber or any part of the pilot. See Figure 3.

Starting Up and Setting Controlled Temperature

Best temperature control will result when the delivery pressure setting is the lowest steam pressure capable of sustaining the desired temperature at maximum load. The following adjustments should be made under full load conditions or as near such as possible:

1. Close by-pass. Open 1/4 in. / 6.35 mm control pipe valve and turn up temperature adjusting wheel, until 1/2 in. / 12.7 mm of thread is exposed. Back off pressure adjusting screw to remove all compression from pressure limit spring. (See Figure 3)

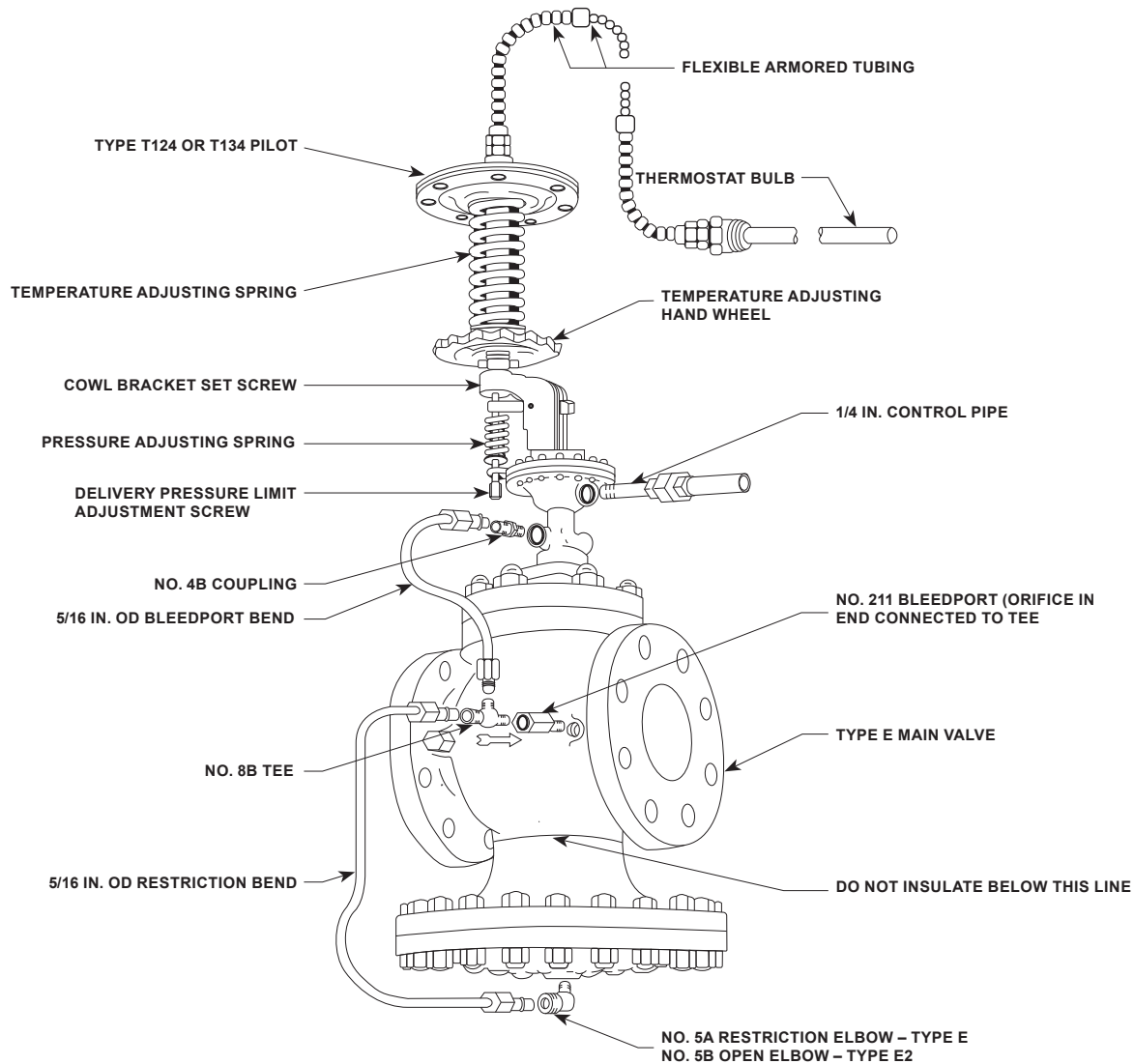

Figure 3. Regulator Assembly for Type ET214 or ET134 with Integrally-Mounted Pilot

2. Crack open outlet stop valve. Crack open inlet stop valve, blow down strainer, then slowly open inlet valve, wide open.
3. Turn up pressure adjustment slowly. When steam begins to flow, open outlet stop valve gradually.
4. Continue delivery pressure adjustment until heater output temperature is 5°F / -15°C above that required. (If the temperature adjustment of paragraph 1 limits this operation, set the adjusting wheel a little higher.)
5. Lower the temperature adjusting wheel until the desired operating temperature is reached.
6. If the adjustment is made at a partial load, the temperature will sag under heavy loads. When maximum load occurs, increase the pressure setting just sufficient to restore the temperature to normal.

Maintenance

WARNING

To avoid personal injury or property damage from sudden release of pressure, isolate the regulator from the pressure system and release all pressure from the pilot and main valve before performing maintenance operations.

ET124 and ET134 Series

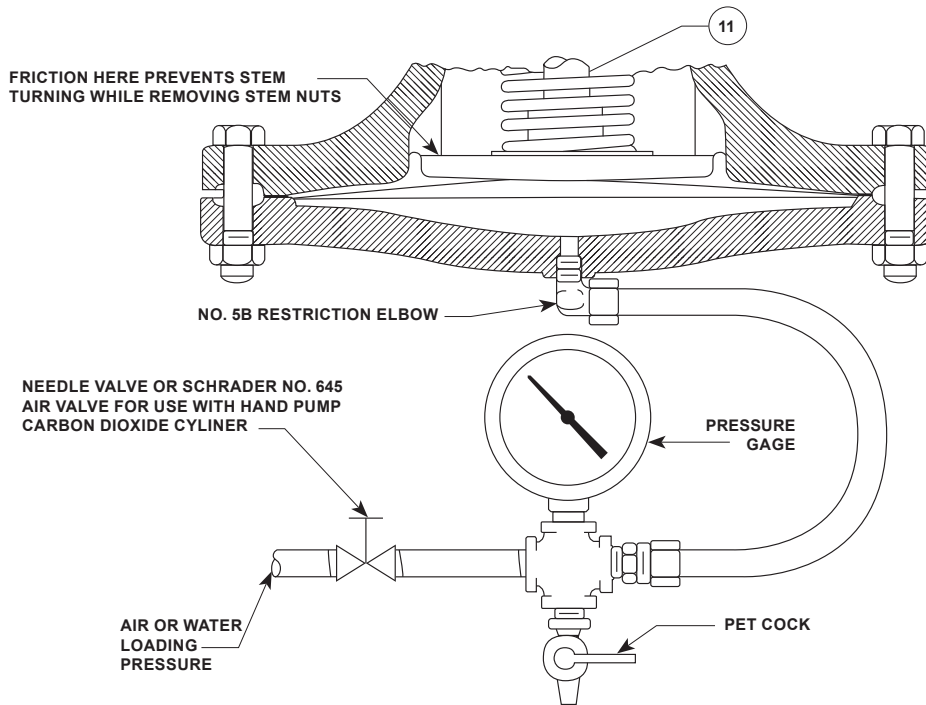

Figure 4. Air Loading Arrangement for Removing Stem Nuts

Complete dismantling at regular intervals for inspection and repair is not recommended. Under normal conditions, if kept relatively free of dirt, a regulator will function year after year with minimum maintenance attention. These service points are suggested:

1. After the first few days and thereafter twice a year, inspect for dirt collected at:
 - a. Bleedport orifice - screwed into the downstream side of the main valve.
 - b. Restriction orifice - screwed into the underside of the main valve Types E and E5. Type E2 main valve has an open elbow without orifice.
2. After the first few days of operation and thereafter twice a year, inspect all flanges and screwed joints for leakage. Tighten all bolts. Never allow a leak to persist.
3. Do not, in under any circumstances, loosen the bolts on the temperature diaphragm chamber or attempt to dismantle the thermostat element. The system is filled with a volatile fluid which if lost, will render the pilot inoperative. A damaged element, however, can easily be changed in the field by following the directions in Form SIOI12B.

Troubleshooting

Failure to Open

1. The setting of adjusting springs may have been tampered with.
2. Initial pressure may be down due to partially-closed supply valve, clogged strainer or other obstruction.
3. Bleedport may have been omitted and an open coupling is substituted.
4. Orifice in No. 5A restriction may be plugged.
5. Control pipe on pilot may be plugged. Most likely, points of obstruction are at shutoff valve and entrance to delivery main valve.
6. Make sure the heater is properly trapped and free of condensate.
7. Pilot or main valve diaphragms may be broken. Check for leakage around the stem between the lever and the diaphragm on pilot. Check the main valve with air pressure in the diaphragm chamber before dismantling.
8. Leak in the thermostat bulb may allow heated fluid pressure, if sufficiently high, to back up into thermal system to hold the pilot closed.

Failure to Close, Overheating

1. The setting of adjusting springs may have been tampered with.
2. By-pass may be leaking.
3. Thermostat is located too far from instantaneous heater outlet.
4. Thermostat may be kinked, broken, or have lost its fill. Alternately warm and cool the bulb at least 10°F / -12°C above and below its setpoint. If the thermostat is operative, the stem between the lever and the pressure diaphragm will become loose and snug as the temperature stem on opposite ends of the lever moves up and down.
5. A lift of condensate to a hot well may require more pressure in the heater than the heated medium.
 - a. Arrange the drainage of the heater by gravity or install a pump to lift condensate.
6. Main valve or pilot may be held open by foreign matters to determine which valve leaks:
 - a. Close the inlet stop valve and 1/4 in. / 6.35 mm control valve.
 - b. Remove the bleed port bend so the pilot will exhaust to atmosphere.
 - c. Remove all compression from the pressure adjusting spring.
 - i. If steam issues from the end of bleedport bend on pilot, there is an obstruction between its seat and disk.
 - ii. Steam blowing back from the bleedport on the downstream side of valve indicates that the main valve disk is held open by a foreign matter.
 - iii. Leakage of wither valve requires dismantling. See dismantling and valve grinding for method.

Erratic Temperature Control

1. Thermostat installed too far from the heater outlet.
2. Improper trapping or erratic discharge of trap.
3. Lift of condensate to hot well may require more pressure than that called for by the medium flowing through the heater.
 - a. Arrange to drain condensate by gravity or lift it with a pump.
4. Sticky check valve in return line.

5. Poor circulation through heater.
 - a. Constant circulation should be employed.
6. Valve is too large for the heater or the heater is too large for load.
7. Valve is installed too far from the heater.

Dismantling

Main Valve

1. Remove the pilot and its connection to the main valve.
2. Remove the top flange of the valve.
3. Connect a source of air (water, steam) pressure which can be adjusted by hand to the underside of the diaphragm as shown in Figure 4.
4. Apply 50 to 60 psi / 3.45 to 4.14 bar to Type E, 10 psi / 0.69 bar to Types E2 and E5 to jack the valve wide open. The friction of the pressure plate against the stops in the base will prevent the stem (key 11) from turning while removing the stem nuts.

Pilot

Note

If possible, remove the bulb of the thermostat from the tank or pipe line. This will make disassembling easier and permit the omission of step 1. If it is not possible to remove the bulb of the thermostat, proceed with step 1.

1. Loosen the set screw in cowl bracket just below the barrel nut and unscrew the pressure pilot from the barrel.
2. Release the compression on the pressure adjusting spring and remove the spring.
3. Remove the flange bolts at the small flange where the pilot connects to the valve, and remove the pilot.
4. Take the pilot body apart at the diaphragm joint.
5. Hold the pusher plate on the upper end of the pilot body to turn off the stem nuts.

Grinding the Main Valve or Pilot Disk

1. Use extremely fine (400 grit) compound with light pressure to avoid tearing of metal.
2. Clean all parts with solvent before reassembling.

ET124 and ET134 Series

Parts Ordering

When corresponding with your local Sales Office about this equipment, always reference the equipment regulator size, service and serial number.

When ordering replacement parts, reference the key number of each needed part as found in the following parts list and indicate the part number.

Parts List

Type E Main Valve

See Instruction Manual VCIMD-14961-EN

Type E2 Main Valve

See Instruction Manual VCIMD-14935-EN

T124 and T134 Series Pilot

See Instruction Manual VCIMD-14980-EN

 [SpenceValve.com](https://www.SpenceValve.com)

Emerson

Americas

McKinney, Texas 75069 USA
T +1 800 558 5853
+1 972 548 3574

Europe

Bologna 40013, Italy
T +39 051 419 0611

Asia Pacific

Singapore 128461, Singapore
T +65 6777 8211

Middle East and Africa

Dubai, United Arab Emirates
T +971 4 811 8100

VCIMD-16109-EN © 2021, 2026 Emerson Electric Co. All rights reserved 02/26. Spence is a mark owned by a subsidiary of Emerson Electric Co. The Emerson logo is a trademark and service mark of Emerson Electric Co. All other marks are property of their respective owners.

Neither Emerson nor any of its affiliated entities assume responsibility for the selection, use or maintenance of any product. Responsibility for proper selection, use, and maintenance of any product remains solely with the purchaser and end user.

The contents of this publication are presented for informational purposes only, and while every effort has been made to ensure their accuracy, they are not to be construed as warranties or guarantees, express or implied, regarding the products or services described herein or their use or applicability. All sales are governed by our terms and conditions, which are available upon request. We reserve the right to modify or improve the designs or specifications of such products at any time without notice.

