

Spence Dura-Flo Series Inverted Bucket Steam Traps



Figure 1. Dura-Flo Series Inverted Bucket Steam Trap

Features

- Hardened Stainless Steel Valve and Seat – Long life and maximum corrosion resistance.
 - Stainless Steel Bucket – Long lasting, rugged and naturally resistant to water hammer.
 - Inexpensive – Low maintenance and initial cost.
 - Repairable in-line – All working parts lift out of top of trap.
 - Cast Iron Body – Durable heavy wall construction provides years of reliable service.
 - Suitable for Wide Variety of Loads/Applications – Horizontal and vertical models in thirteen body sizes.
- Resists Dirt and Scale – Valve and seats positioned at top of traps and internal stainless strainer available on most horizontal models ensure long service.

Introduction

A steam trap is an automatic valve which discharges condensate, undesirable air and non-condensibles from a system while trapping, or holding in, steam.

Dura-Flo Series inverted bucket traps are capable of discharging condensate, air and other non-condensable gases without loss of steam. These traps have a heavy cast iron body, hardened stainless steel valve and seat, all stainless steel linkage and bucket and a graphite fiber cover gasket.

Dura-Flo Series

Specifications

The Specifications section gives some general specifications for the Dura-Flo Series inverted bucket steam traps. The nameplates give detailed information for a specific steam trap as built in the factory.

Available Configurations

- Type 80S:** Low capacity horizontal with integral strainer
- Type 81S:** Medium low capacity horizontal with integral strainer
- Type 82S:** Medium capacity horizontal with integral strainer
- Type 83S:** Medium high capacity horizontal with integral strainer
- Type 84:** High capacity horizontal
- Type 85:** Super high capacity horizontal
- Type 86:** Ultra high capacity horizontal
- Type 21:** Medium low capacity vertical
- Type 22:** Medium capacity vertical
- Type 23:** Medium high capacity vertical
- Type 24:** High capacity vertical
- Type 25:** Super high capacity vertical
- Type 26:** Ultra high capacity vertical

Available Sizes

NPS 1/2, 3/4, 1, 1-1/4, 1-1/2, 2 and 2-1/2 /
DN 15, 20, 25, 32, 40, 50 and 60

End Connection Styles

NPT

Maximum Operating Pressure⁽¹⁾

See Tables 1 and 2

Maximum Operating Temperature⁽¹⁾

Saturated at pressure

Maximum Allowable Pressure⁽¹⁾

250 psig / 17.2 bar

Maximum Allowable Temperature⁽¹⁾

450°F / 232°C

Capacity Information

See Tables 1 and 2

Materials of Construction

Body and Cover: Cast Iron

Bucket and Linkage: Stainless steel

Valve and Seat: Hardened Chrome Steel

Standpipe: Steel pipe

Cover Gasket: Graphite

Option

Repair Kits

Applications

- Steam Lines
- Process Equipment
- Steam Cookers
- Steam Heated Vats
- Pressing Machinery
- Unit Heaters
- Oil Preheaters
- Converters
- Coils
- Rotating Drum

Approximate Weights

7 to 90 lbs / 3.2 to 40.8 kg

1. The pressure/temperature limits in this Bulletin and any applicable standard or code limitation should not be exceeded.

Principle of Operation

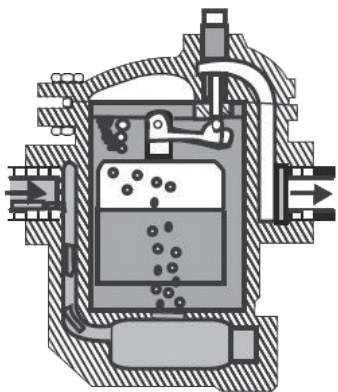

Figure 2. Dura-Flo Series Inverted Bucket Steam Trap Closed

Steam entering the trap collects in the top of the bucket, floating the bucket and forcing the valve into its seat.

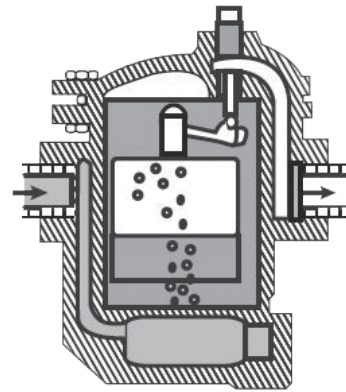

Figure 3. Dura-Flo Series Inverted Bucket Steam Trap Begins to Open

As the condensate begins to flow into the trap, the steam and air are forced from the bucket. This causes the bucket to begin losing buoyancy, tending to pull the valve from its seat.

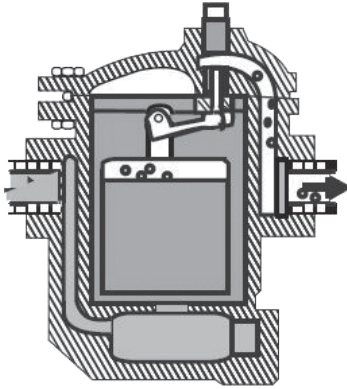

Figure 4. Dura-Flo Series Inverted Bucket Steam Trap Discharges

When enough condensate has entered the trap, displacing the steam and air, the bucket drops, pulling the valve from the seat and allowing condensate and air to discharge.

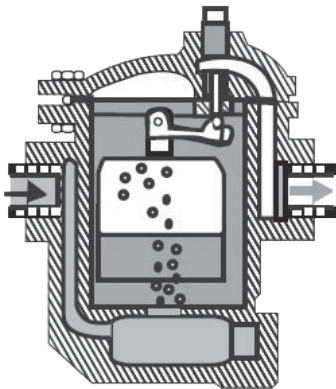

Figure 5. Dura-Flo Series Inverted Bucket Steam Trap Closes

As the flow of condensate stops, steam enters the trap and re-floats the bucket, forcing the valve into its seat. The cycle repeats as more condensate reaches the trap.

Installation

- Install the traps in an accessible position and location for easy servicing. Allow vertical clearance for maintenance.
- Install the trap with the body upright so that bucket is rising and falling vertically.
- Install the inlet and outlet connections in a horizontal plane for horizontal traps and a vertical plane with inlet on the bottom for vertical traps.
- Avoid long lengths of horizontal piping ahead of trap.
- Pitch all horizontal inlet lines towards the steam trap to help eliminate potential water hammer problems.
- Install the trap below the drain point, so that a water seal can be maintained around the open end of the bucket.
- Install the trap below and close to equipment being drained.
- The maximum differential pressure (ΔP) stamped on product nameplate must be greater than the maximum pressure differential across the trap.
- For all models, install a strainer ahead of trap.
- Install union fittings and shut off valves on both sides of trap for ease of servicing and trap testing.
- Install a test and pressure relief valve to ensure relief of internal pressure prior to servicing and as a visual indication of trap operation.
- If there will be a pressurized return line or the trap drains to an overhead return line, install a check valve on return piping.

Ordering Information

When ordering, complete the ordering guide on this page. Refer to the Specifications section. Review the description to the right of each specification and the information in each referenced table or figure. Specify your choice whenever a selection is offered.

Dura-Flo Series

Table 1. Maximum Capacity - lbs/hr 10°F Below Saturation

TYPE	ORIFICE, In.	MAX. ΔP psig	DIFFERENTIAL PRESSURE, psig									
			0.5	1	5	10	15	20	25	30	40	60
80S	3/16	20	200	270	450	560	640	690	----	----	----	----
	1/8	80	80	110	200	300	360	420	460	500	540	620
	7/64	125	----	55	90	145	195	260	305	345	400	485
	3/32	150	----	----	70	110	150	200	240	270	310	380
81S and 21	1/4	15	300	450	830	950	1060	----	----	----	----	----
	3/16	30	190	300	540	670	770	880	950	1000	----	----
	5/32	70	100	165	180	430	495	585	655	710	770	900
	1/8	125	70	130	220	340	390	460	515	560	610	710
	7/64	200	----	65	150	230	275	335	375	405	455	545
	3/32	250	----	----	100	150	190	240	270	290	340	420
82S and 22	5/16	15	570	850	1600	1900	2100	----	----	----	----	----
	1/4	30	350	500	950	1380	1630	1800	1900	2050	----	----
	3/16	70	250	420	785	950	1120	1260	1395	1500	1700	2000
	5/32	125	180	300	560	680	800	900	995	1070	1220	1440
	1/8	200	100	180	325	465	505	575	650	710	805	980
	7/64	250	75	130	240	340	370	420	480	520	590	720
83S and 23	1/2	15	1410	1880	2900	3500	3900	----	----	----	----	----
	3/8	30	990	1400	2300	2700	3300	3500	3800	4000	----	----
	5/16	60	600	940	1730	2045	2510	2825	2995	3135	3800	4400
	9/32	80	510	735	1350	1595	1960	2205	2340	2450	2880	3490
	1/4	125	385	600	1100	1300	1600	1800	1910	2000	2350	2850
	7/32	180	300	490	860	1165	1350	1595	1865	2085	2205	2510
	3/16	250.00	255	400	700	950	1100	1300	1520	1700	1800	2050
84 and 24	5/8	15.00	2160	2900	4800	5800	6500	----	----	----	----	----
	1/2	30.00	1450	2250	3700	4750	5200	6000	6500	6800	----	----
	3/8	60.00	1050	1750	2950	3550	4000	4700	5000	5400	5800	6800
	11/32	80.00	800	1560	2500	2900	3200	3500	4000	4400	4850	5750
	5/16	125.00	660	1200	1950	2450	2750	3100	3250	3500	4000	4800
	9/32	180.00	550	950	1500	1900	2200	2350	2700	2900	3250	3800
	1/4	250.00	350	580	1000	1250	1450	1800	2000	2200	2600	3150
	3/4	15.00	3100	4160	7600	9000	10000	----	----	----	----	----
85 and 25	9/16	30.00	1800	2900	5200	6400	7700	8500	9200	9800	----	----
	7/16	60.00	1400	2200	3800	5000	6000	6600	7100	7600	8300	9500
	3/8	100.00	1100	1700	3000	3600	4500	5200	5800	6100	7000	8500
	11/32	130.00	900	1500	2600	3200	3900	4500	5000	5400	6200	7500
	5/16	180.00	750	1200	2100	2600	3200	3700	4100	4500	5400	6600
	9/32	225.00	600	970	1700	2100	2600	2950	3300	3600	4500	5400
	1/4	250.00	400	700	1200	1500	1900	2100	2400	2600	3200	3800
	11/16	15.00	6240	8400	14500	17300	19200	----	----	----	----	----
86 and 26	7/8	25.00	4100	5490	10000	12930	15620	18500	20000	----	----	----
	3/4	40.00	2900	4500	8200	10600	12800	15000	16700	18000	20000	----
	5/8	60.00	2100	3500	6900	8700	10600	12100	13300	14250	16300	19800
	9/16	80.00	1900	3095	6000	7600	9300	10600	11700	12500	14300	17300
	1/2	125.00	1600	2600	5000	6400	7800	8900	9800	10500	12000	14500
	7/16	180.00	1400	2210	4180	5530	6640	7500	8490	9230	10450	12420
	3/8	250.00	1000	1800	3400	4500	5400	6100	6900	7500	8500	10100

Table 1. Maximum Capacity - lbs/hr 10°F Below Saturation (continued)

TYPE	ORIFICE, In.	MAX. ΔP psig	DIFFERENTIAL PRESSURE, psig									
			70	80	100	125	130	150	180	200	225	250
80S	3/16	20	----	----	----	----	----	----	----	----	----	----
	1/8	80	660	690	----	----	----	----	----	----	----	----
	7/64	125	525	565	640	680	----	----	----	----	----	----
	3/32	150	410	440	480	540	545	570	----	----	----	----
81S and 21	1/4	15	----	----	----	----	----	----	----	----	----	----
	3/16	30	----	----	----	----	----	----	----	----	----	----
	5/32	70	950	----	----	----	----	----	----	----	----	----
	1/8	125	760	800	860	950	----	----	----	----	----	----
	7/64	200	580	610	665	735	780	810	850	860	----	----
3/32	250	450	470	520	575	585	620	670	700	730	760	
82S and 22	5/16	15	----	----	----	----	----	----	----	----	----	----
	1/4	30	----	----	----	----	----	----	----	----	----	----
	3/16	70	2200	----	----	----	----	----	----	----	----	----
	5/32	125	1550	1650	1800	2000	----	----	----	----	----	----
	1/8	200	1050	1105	1225	1375	1410	1500	1560	1600	----	----
7/64	250	770	810	900	1010	1020	1100	1170	1230	1280	1300	
83S and 23	1/2	15	----	----	----	----	----	----	----	----	----	----
	3/8	30	----	----	----	----	----	----	----	----	----	----
	5/16	60	----	----	----	----	----	----	----	----	----	----
	9/32	80	3800	4000	----	----	----	----	----	----	----	----
	1/4	125	3100	3300	3600	3900	----	----	----	----	----	----
	7/32	180	2695	2820	3065	3185	3300	3500	3700	----	----	----
	3/16	250.00	2200	2300	2500	2600	2700	2800	3020	3200	3400	3500
84 and 24	5/8	15.00	----	----	----	----	----	----	----	----	----	----
	1/2	30.00	----	----	----	----	----	----	----	----	----	----
	3/8	60.00	----	----	----	----	----	----	----	----	----	----
	11/32	80.00	6000	6400	----	----	----	----	----	----	----	----
	5/16	125.00	5250	5600	6200	6700	----	----	----	----	----	----
	9/32	180.00	4250	4500	4800	5500	5600	5700	6000	----	----	----
	1/4	250.00	3350	3500	3800	4300	4450	4700	5000	5300	5500	5700
85 and 25	3/4	15.00	----	----	----	----	----	----	----	----	----	----
	9/16	30.00	----	----	----	----	----	----	----	----	----	----
	7/16	60.00	----	----	----	----	----	----	----	----	----	----
	3/8	100.00	9200	9700	10400	----	----	----	----	----	----	----
	11/32	130.0	8050	8500	9600	10900	11000	----	----	----	----	----
	5/16	180.0	7000	7257	8118	8979	9041	9500	10000	----	----	----
	9/32	225.0	5700	5900	6600	7300	7350	7850	8400	9200	9800	----
1/4	250.0	4000	4150	4600	5100	5150	5500	5950	6350	6650	7000	
86 and 26	1-1/16	15.0	----	----	----	----	----	----	----	----	----	----
	7/8	25.0	----	----	----	----	----	----	----	----	----	----
	3/4	40.0	----	----	----	----	----	----	----	----	----	----
	5/8	60.0	----	----	----	----	----	----	----	----	----	----
	9/16	80.0	18300	19000	----	----	----	----	----	----	----	----
	1/2	125.0	15400	16300	18000	20000	----	----	----	----	----	----
	7/16	180.0	13300	14150	15750	17400	17900	18500	20000	----	----	----
3/8	250.0	10800	11500	12800	14200	14300	15600	16900	17500	18500	19000	

Dura-Flo Series

Table 2. Maximum Capacity - kg/hr 5°C Below Saturation

TYPE	ORIFICE, mm	MAX. ΔP bar	DIFFERENTIAL PRESSURE, bar									
			0.03	0.07	0.34	0.69	1.03	1.38	1.72	2.07	2.76	4.14
80S	4.76	1.38	91	122	204	254	290	313	----	----	----	----
	3.18	5.52	36	50	91	136	163	191	209	227	245	281
	2.78	8.62	0	25	41	66	88	118	138	156	181	220
	2.38	10.34	0	0	32	50	68	91	109	122	141	172
81S and 21	6.35	1.03	136	204	376	431	481	----	----	----	----	----
	4.76	2.07	86	136	245	304	349	399	431	454		
	3.97	4.83	45	75	82	195	225	265	297	322	349	408
	3.18	8.62	32	59	100	154	177	209	234	254	277	322
	2.78	13.79	0	29	68	104	125	152	170	184	206	247
	2.38	17.24	0	0	45	68	86	109	122	132	154	191
82S and 22	7.94	1.03	259	386	726	862	953	----	----	----	----	----
	6.35	2.07	159	227	431	626	739	816	862	930	----	----
	4.76	4.83	113	191	356	431	508	572	633	680	771	907
	3.97	8.62	82	136	254	308	363	408	451	485	553	653
	3.18	13.79	45	82	147	211	229	261	295	322	365	445
	2.78	17.24	34	59	109	154	168	191	218	236	268	327
83S and 23	12.70	1.03	640	853	1315	1588	1769	----	----	----	----	----
	9.53	2.07	449	635	1043	1225	1497	1588	1724	1814	----	----
	7.94	4.14	272	426	785	928	1139	1281	1359	1422	1724	1996
	7.14	5.52	231	333	612	723	889	1000	1061	1111	1306	1583
	6.35	8.62	175	272	499	590	726	816	866	907	1066	1293
	5.56	12.41	136	222	390	528	612	723	846	946	1000	1139
	4.76	17.24	116	181	318	431	499	590	689	771	816	930
	15.88	1.03	980	1315	2177	2631	2948	----	----	----	----	----
84 and 24	12.70	2.07	658	1021	1678	2155	2359	2722	2948	3084	----	----
	9.53	4.14	476	794	1338	1610	1814	2132	2268	2449	2631	3084
	8.73	5.52	363	708	1134	1315	1452	1588	1814	1996	2200	2608
	7.94	8.62	299	544	885	1111	1247	1406	1474	1588	1814	2177
	7.14	12.41	249	431	680	862	998	1066	1225	1315	1474	1724
	6.35	17.24	159	263	454	567	658	816	907	998	1179	1429
	19.05	1.03	1406	1887	3447	4082	4536	----	----	----	----	----
85 and 25	14.29	2.07	816	1315	2359	2903	3493	3856	4173	4445	----	----
	11.11	4.14	635	998	1724	2268	2722	2994	3221	3447	3765	4309
	9.53	6.90	499	771	1361	1633	2041	2359	2631	2767	3175	3856
	8.73	8.96	408	680	1179	1452	1769	2041	2268	2449	2812	3402
	7.94	12.41	340	544	953	1179	1452	1678	1860	2041	2449	2994
	7.14	15.51	272	440	771	953	1179	1338	1497	1633	2041	2449
	6.35	17.24	181	318	544	680	862	953	1089	1179	1452	1724
	26.99	1.03	2830	3810	6577	7847	8709	----	----	----	----	----
86 and 26	22.23	1.72	1860	2490	4536	5865	7085	8392	9072	----	----	----
	19.05	2.76	1315	2041	3720	4808	5806	6804	7575	8165	9072	----
	15.88	4.14	953	1588	3130	3946	4808	5489	6033	6464	7394	8981
	14.29	5.52	862	1404	2722	3447	4218	4808	5307	5670	6486	7847
	12.70	8.62	726	1179	2268	2903	3538	4037	4445	4763	5443	6577
	11.11	12.41	635	1002	1896	2508	3012	3402	3851	4187	4740	5634
	9.53	17.24	454	816	1542	2041	2449	2767	3130	3402	3856	4581

Table 2. Maximum Capacity - kg/hr 5°C Below Saturation (continued)

TYPE	ORIFICE, mm	MAX. ΔP bar	DIFFERENTIAL PRESSURE, bar										
			4.83	5.52	6.90	8.62	8.96	10.3	12.4	13.8	15.5	17.2	
80S	4.76	1.38	----	----	----	----	----	----	----	----	----	----	----
	3.18	5.52	299	313	----	----	----	----	----	----	----	----	----
	2.78	8.62	238	256	290	308	----	----	----	----	----	----	----
	2.38	10.34	186	200	218	245	247	259	----	----	----	----	----
81S and 21	6.35	1.03	----	----	----	----	----	----	----	----	----	----	----
	4.76	2.07	----	----	----	----	----	----	----	----	----	----	----
	3.97	4.83	431	----	----	----	----	----	----	----	----	----	----
	3.18	8.62	345	363	390	431	----	----	----	----	----	----	----
	2.78	13.79	263	277	302	333	354	367	386	390	----	----	----
2.38	17.24	204	213	236	261	265	281	304	318	318	331	345	
82S and 22	7.94	1.03	----	----	----	----	----	----	----	----	----	----	----
	6.35	2.07	----	----	----	----	----	----	----	----	----	----	----
	4.76	4.83	998	----	----	----	----	----	----	----	----	----	----
	3.97	8.62	703	748	816	907	----	----	----	----	----	----	----
	3.18	13.79	476	501	556	624	640	680	708	726	----	----	----
2.78	17.24	349	367	408	458	463	499	531	558	581	590	----	
83S and 23	12.70	1.03	----	----	----	----	----	----	----	----	----	----	----
	9.53	2.07	----	----	----	----	----	----	----	----	----	----	----
	7.94	4.14	----	----	----	----	----	----	----	----	----	----	----
	7.14	5.52	1724	1814	----	----	----	----	----	----	----	----	----
	6.35	8.62	1406	1497	1633	1769	----	----	----	----	----	----	----
	5.56	12.41	1222	1279	1390	1445	1497	1588	1678	----	----	----	----
	4.76	17.24	998	1043	1134	1179	1225	1270	1370	1452	1542	1588	----
84 and 24	15.88	1.03	----	----	----	----	----	----	----	----	----	----	----
	12.70	2.07	----	----	----	----	----	----	----	----	----	----	----
	9.53	4.14	----	----	----	----	----	----	----	----	----	----	----
	8.73	5.52	2722	2903	----	----	----	----	----	----	----	----	----
	7.94	8.62	2381	2540	2812	3039	----	----	----	----	----	----	----
	7.14	12.41	1928	2041	2177	2495	2540	2586	2722	----	----	----	----
	6.35	17.24	1520	1588	1724	1950	2019	2132	2268	2404	2495	2586	----
85 and 25	19.05	1.03	----	----	----	----	----	----	----	----	----	----	----
	14.29	2.07	----	----	----	----	----	----	----	----	----	----	----
	11.11	4.14	----	----	----	----	----	----	----	----	----	----	----
	9.53	6.90	4173	4400	4717	----	----	----	----	----	----	----	----
	8.73	8.96	3651	3856	4355	4944	4990	----	----	----	----	----	----
	7.94	12.41	3175	3292	3682	4073	4101	4309	4536	----	----	----	----
	7.14	15.51	2586	2676	2994	3311	3334	3561	3810	4173	4445	----	----
6.35	17.24	1814	1882	2087	2313	2336	2495	2699	2880	3016	3175	----	
86 and 26	26.99	1.03	----	----	----	----	----	----	----	----	----	----	----
	22.23	1.72	----	----	----	----	----	----	----	----	----	----	----
	19.05	2.76	----	----	----	----	----	----	----	----	----	----	----
	15.88	4.14	----	----	----	----	----	----	----	----	----	----	----
	14.29	5.52	8301	8618	----	----	----	----	----	----	----	----	----
	12.70	8.62	6985	7394	8165	9072	----	----	----	----	----	----	----
	11.11	12.41	6033	6418	7144	7893	8119	8392	9072	----	----	----	----
9.53	17.24	4899	5216	5806	6441	6486	7076	7666	7938	8392	8618	----	

Dura-Flo Series

Ordering Guide

Available Configurations (Select One)

- Type 80S
- Type 81S
- Type 82S
- Type 83S
- Type 84
- Type 85
- Type 86
- Type 21
- Type 22
- Type 23
- Type 24
- Type 25
- Type 26

Body Sizes (Select One)

- NPS 1/2 / DN 15
- NPS 3/4 / DN 20
- NPS 1 / DN 25
- NPS 1-1/4 / DN 32
- NPS 1-1/2 / DN 40
- NPS 2 / DN 50
- NPS 2-1/2 / DN 60

Option

- Repair Kits

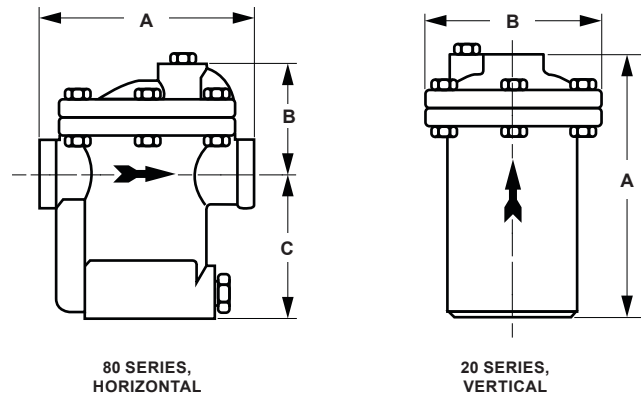

Figure 6. Dura-Flo Series Inverted Bucket Steam Trap Dimension

Table 3. Dura-Flo Series Dimension

TYPE	SIZE		A		B		C		Weight	
	NPS	DN	In.	mm	In.	mm	In.	mm	Lb.	kg
80S	1/2 and 3/4	15 and 20	5-1/16	129	2-11/16	69	3-1/2	89	7	3.2
81S	1/2, 3/4 and 1	15, 20 and 25	5-1/16	129	2-11/16	69	4-7/16	113	8	3.6
82S	1/2 and 3/4	15 and 20	7	178	3-7/8	98	5-7/16	138	22	10.0
83S	3/4 and 1	20 and 25	8-1/8	206	5	127	7-5/8	194	32	14.5
84	1 and 1-1/4	25 and 32	9	229	5-3/4	146	7-13/16	199	47	21.3
85	1-1/2 and 2	40 and 50	10-1/4	260	8	203	8-3/8	213	74	33.6
86	2 and 2-1/2	50 and 60	13	330	9-3/4	248	11	279	140	63.5
21	1/2	15	6-3/8	162	4-1/4	108	----	----	6.5	2.9
22	1/2 and 3/4	15 and 20	8	203	5-5/8	143	----	----	16	7.3
23	3/4 and 1	20 and 25	10-1/2	267	6-7/8	175	----	----	28	12.7
24	1 and 1-1/4	25 and 32	12-1/2	318	7-1/2	190	----	----	35	15.9
25	1 and 1-1/2	25 and 40	14-3/8	365	9-1/16	230	----	----	60	27.2
26	1/2 and 2	15 and 50	16-11/16	424	10-1/4	260	----	----	90	40.8

SpenceValve.com

Emerson Automation Solutions

Americas

McKinney, Texas 75070 USA
T +1 800 558 5853
+1 972 548 3574

Europe

Bologna 40013, Italy
T +39 051 419 0611

Asia Pacific

Singapore 128461, Singapore
T +65 6777 8211

Middle East and Africa

Dubai, United Arab Emirates
T +971 4 811 8100

VCBUL-16309 © 2021 Emerson Electric Co. All rights reserved 11/21.

Spence is a mark owned by one of the companies in the Emerson Automation Solutions business unit of Emerson Electric Co. The Emerson logo is a trademark and service mark of Emerson Electric Co. All other marks are property of their prospective owners.

The contents of this publication are presented for informational purposes only, and while every effort has been made to ensure their accuracy, they are not to be construed as warranties or guarantees, express or implied, regarding the products or services described herein or their use or applicability. All sales are governed by our terms and conditions, which are available upon request. We reserve the right to modify or improve the designs or specifications of such products at any time without notice.

Emerson Electric Co. does not assume responsibility for the selection, use or maintenance of any product. Responsibility for proper selection, use and maintenance of any Emerson Electric Co. product remains solely with the purchaser.

