

October 2022

Spence™ TA Series Thermostatic Steam Traps

WARNING

Failure to follow these instructions or to properly install and maintain this equipment could result in an explosion, fire and/or chemical contamination causing property damage and personal injury or death.

The TA Series Steam Trap must be installed, operated and maintained in accordance with federal, state and local codes, rules and regulations and Emerson instructions.

If leak develops in the system, service to the unit may be required. Failure to correct trouble could result in a hazardous condition.

Installation, operation and maintenance procedures performed by unqualified personnel may result in improper adjustment and unsafe operation. Either condition may result in equipment damage or personal injury. Only a qualified person shall install or service the TA Series Steam Trap.

WARNING

CALIFORNIA PROPOSITION 65

This product can expose you to chemicals including nickel which is known to the State of California to cause cancer, birth defects or other reproductive harm. For more information, go to www.P65Warnings.ca.gov.

Introduction

Scope of the Manual

This manual provides instructions for installation, maintenance and parts information for the TA Series Thermostatic Steam Traps.



Figure 1. TA Series Thermostatic Steam Trap

Product Description

A steam trap is an automatic valve which discharges condensate, undesirable air and non-condensibles from a system while trapping, or holding in steam. Thermostatic steam traps operate in direct response to the temperature within the trap.

The TA Series is a balanced pressure design with stainless steel welded actuator capable of discharging condensate within 10°F / -12°C of saturated temperature.

For greater sensitivity or protection from flash steam locking, SLR orifice is available to allow condensate and flash steam evacuation at or near saturated temperatures. If subcooling of condensate is desired, alternate thermostatic actuator is available to allow condensate evacuation at or near 40°F / 4.4°C below saturated temperatures.

Thermostatic actuator has a conical valve lapped in matched sets with the seat ring assuring tight shut off. A minimum of three orifice sizes are available allowing for custom capacity sizing. Trap is stainless steel-bodied suitable for pressures up to 650 psig / 44.8 bar and available in NPS 3/8 to 1 / DN 10 to 25 in NPT or socket weld end connection.

TA Series

Specifications

This section lists the specifications for the TA Series. Factory specifications are stamped on the nameplate fastened on the steam trap at the factory.

Available Configurations⁽¹⁾

Type TA502: Reduced capacity

Type TA503: Standard capacity

Type TA504: High capacity

Body Sizes

NPS 3/8, 1/2, 3/4 and 1 / DN 10, 15, 20 and 25

End Connection Styles

NPT and Socket Weld

Maximum Operating Pressures⁽²⁾

Standard Traps: 500 psig / 34.5 barg

ISO Option Traps: 650 psig / 44.8 barg

Maximum Allowable Pressure⁽²⁾

650 psig / 44.8 barg

Maximum Operating Temperatures⁽²⁾

Standard Traps: 600°F / 316°C

ISO Option Traps: 650°F / 343°C

Maximum Allowable Temperature⁽²⁾

750°F / 399°C

Materials of Construction

Body and Cover: Stainless steel

Actuator: Welded Stainless Steel

Valve and Seat: Hardened 416 Stainless Steel

Applications

Unit Heaters

Air Vents

Steam Tracing

Drip Legs

Platen Presses

Plating Tanks

Sterilizers

Tire Presses

Cooking Equipment

Laundry Equipment

Other Process Equipment

Options

ISO: ISO Filled Actuator

SW: Socket weld

SLR: SLR Orifice

Approximate Weights

NPS 3/8 and 1/2 / DN 10 and 15: 1.1 lbs / 0.5 kg

NPS 3/4 / DN 20: 1.2 lbs / 0.54 kg

NPS 1 / DN 25: 1.6 lbs / 0.73 kg

1. Add (-FC) for fail closed or (-FO) for fail open to the end of the type number.

2. The pressure/temperature limits in this Instruction Manual and any applicable standard or code limitation should not be exceeded.

Principle of Operation

Thermal actuator is filled at its free length with a liquid having a lower boiling point than water. As assembled, valve is normally open. When very hot condensate enters trap, thermal actuator fill vaporizes to a pressure higher than line pressure. This forces valve into seat orifice to prevent any further flow. As condensate collects, it takes heat from the actuator, lowering internal pressure. Line pressure will then compress thermal actuator to open valve and discharge condensate. Valve opening automatically adjusts to load conditions from minimum on very light loads to full lift at maximum load. Restricted orifice in Type TA502 (small opening at bottom of valve seat) prevents trap from discharging continuously on light loads such as steam and condensate that are encountered on tracer lines.

Installation



WARNING

Personal injury or system damage may result if this steam trap is installed, without appropriate overpressure protection, where service conditions could exceed the limits given in the Specifications section and/or steam trap nameplate.

Additionally, physical damage to the steam trap may result in personal injury or property damage due to escaping of accumulated gas. To avoid such injury and damage, install the steam trap in a safe location.

All pressure equipment should be installed in a non-seismic area; should not be exposed to fire; and should be protected from thunderbolt (lightning) strikes.

1. Before installing trap, blow steam through equipment and piping to remove scale, pipe threading chips and other dirt.
2. Ensure that the trap is suitable for maximum steam pressure to which it will be subjected.

Note

Emerson Thermostatic Steam Traps do not require change of parts for different pressures.

3. Check arrows on trap body or cover to ensure that flow direction is correct.
4. Locate trap accessibly and if possible, below drain outlet for rapid testing and cleaning.
5. Use a separate trap for each unit, coil, surface, chest, etc.
6. Provide uninsulated condensate reservoir and cooling leg between outlet of equipment and trap inlet. See Figure 2.
7. Include unions in inlet and outlet piping if trap will be removed from installed location for cleaning and maintenance.
8. Install an Emerson strainer, a dirt pocket or both, close to trap inlet. See Figures 3, 4 and 5.
9. Include gate valves in inlet and outlet piping so that other plant operations can continue while trap is being cleaned, serviced or maintained. See Figure 7.
10. Install a check valve close to the trap outlet, if discharging to a common return main, and whenever condensate must be lifted after passing through the trap. See Figure 6.
11. Provide an Emerson STV three-way test valve that discharges into return mains in piping close to trap outlet for quick testing. See Figure 7.
12. Provide a water seal at the bottom of the riser if trap is located above an equipment drain and whenever condensate is lifted to the trap. See Figure 8.
13. For piping conditions in step 12, for siphon-drained equipment and for tilting jacketed kettle, specify Emerson traps with “steam lock release valves” (SLR).
14. Ensure that freeze-proof traps are installed on outdoor applications. Spence Types A, C, CS and N125 traps are freeze-proof. Types N450, UMT450, N650, AHV and TA traps are freeze-proof when piped vertically with outlet down (see step 22).
15. Provide condensate-collecting pockets for traps draining steam mains, headers, risers and branches.
16. Ensure that return main is large enough to handle the condensate from all traps discharging into it, without causing excessive back pressure.
17. Always discharge high and low pressure traps into separate return mains.
18. Do not insulate the trap or the piping and fittings between equipment outlet and trap inlet unless absolutely essential.
19. Do not use piping, nipples and fittings smaller than trap connection size.
20. If possible, do not install trap with a long horizontal run of piping between equipment outlet and trap inlet. If such a hook-up is necessary, specify Emerson Traps with “steam lock release valves” (SLR).
21. Do not include a by-pass around trap unless equipment drained must be kept in operation while trap is being cleaned or serviced.
22. Do not jeopardize the advantage of a freeze-proof trap by lifting the condensate or by the use of horizontal piping from the trap outlet without considerable pitch in the direction of flow or by piping the trap in any way which will prevent fast gravity drainage when steam is turned off.

Recommended Piping Layouts

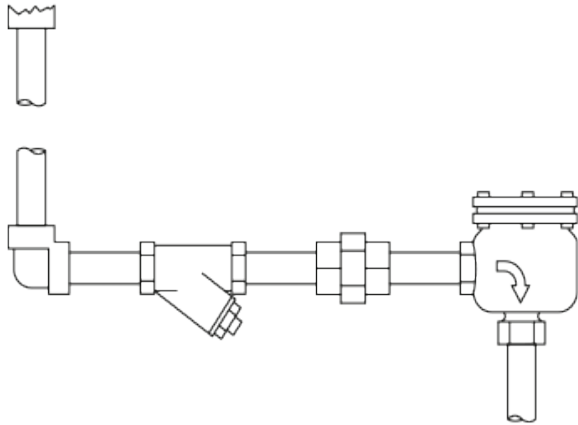

Figure 2. Ample UNINSULATED cooling leg and strainer. If 18 in. / 457 mm vertical cooling leg is not available, make up the difference with horizontal piping.

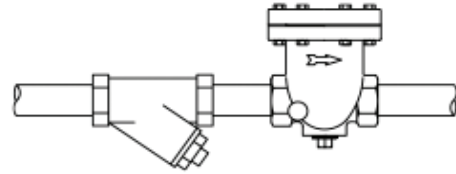

Figure 3. TA Series Industrial Traps have either vertical or horizontal outlets. Pipe plug is for draining if there is danger of freeze-up.

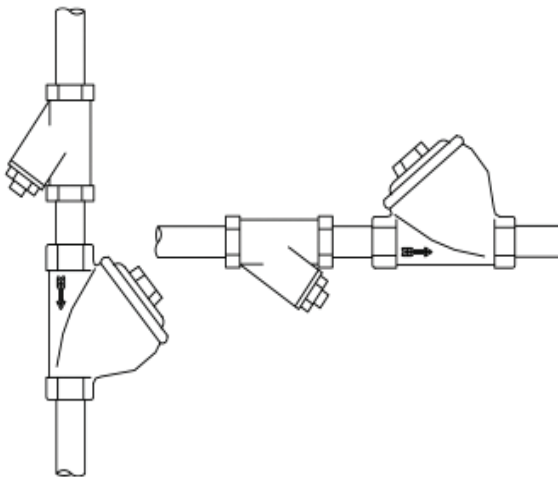

Figure 4. Types AHV, N450, N650, TA and UMT450 Industrial Steam Traps can be mounted either horizontally or vertically. They are freeze-proof when mounted vertically.

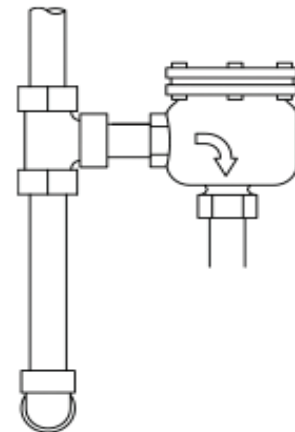

Figure 5. Dirt pocket made from pipe fittings when a strainer is not available. Clean dirt pockets and strainers frequently.

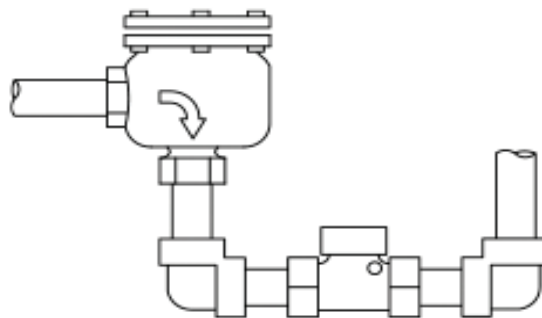

Figure 6. Check valve installed at the discharge of trap when condensate must be lifted or when return line backpressure exists. Condensate can be lifted 2 ft / 0.61 m for each PSI pressure at trap.

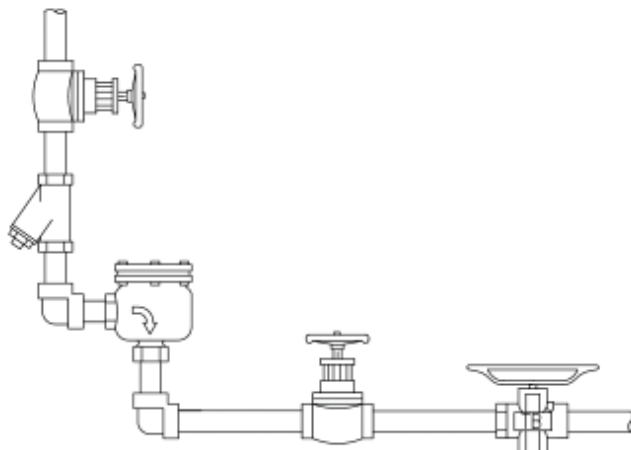

Figure 7. To determine if trap is working properly, turn STV handwheel to test position. This directs trap discharge to ground. Check for continuous flow of condensate, slight or no flow and live steam. Do not mistake normal flash steam with hot condensate for live steam. After testing, be sure STV is positioned to allow condensate discharge to the condensate return system.

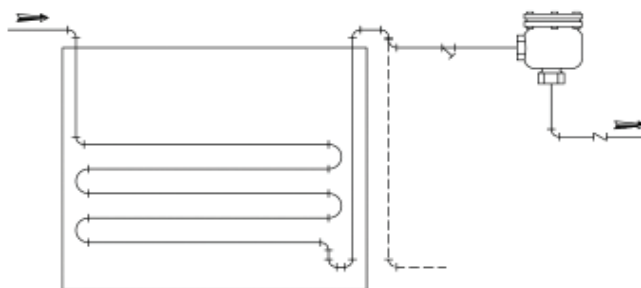

Figure 8. Recommended piping diagram for applications where condensate must be lifted to the trap.

Operation and Testing

1. When steam is first turned on, the large, wide-open orifice of an Emerson trap will quickly discharge all “warm-up” condensate and air from equipment drained. After this initial load has been expelled, live steam will follow and its heat generates a balancing pressure inside bellows, the bellows will immediately expand, closing the valve. Thereafter, trap operation will be intermittent, without live steam discharge, the frequency and duration of the cycles depending on the steam pressure, the amount of condensate and air coming to the trap and the condensate temperature.
2. Periodically test the operation of all traps, which are piped so that the discharge will not be observed. Use a three-way test valve for visual discharge. If test valves have not been installed, check temperatures of inlet and outlet piping close to the trap. Use a surface pyrometer or an infrared temperature device to detect temperature.
 - a. If inlet piping is hotter than outlet piping, with temperature of latter rising and falling in sequence with trap discharge, trap is satisfactory.
 - b. If inlet piping is considerably cooler than known temperature of the steam supplied to equipment drained, trap is either not discharging or is too small for the application.
 - c. A stethoscope or ultrasonic device can be utilized for testing intermittent discharge types of traps, but some experience is necessary to distinguish proper trap operation.
3. The recommended frequency of trap testing depends on the importance of each application and the operating conditions. There is no hard and fast rule, but in general, traps on critical applications should be tested daily to weekly; weekly to monthly for less important equipment.
4. Be aware with the difference between the unavoidable flash vapor in trap discharge and a live steam leak. Flash steam is white and wet, and most evident while the trap is discharging. Live steam has a bluish tint, is dry and hot, and may blow continuously.

Maintenance



Never open a steam shut off valve rapidly. Condensate always collects at the upstream side of a closed, untrapped steam valve. Waterhammer, destructive to equipment, piping and traps, can be initiated by quick opening of such valves.

1. Test traps periodically. Adopt a reasonable "Preventive Maintenance" program to schedule all traps for internal inspection and cleaning at least once a year.
2. Do not remove cover while the trap is very hot. Wait until steam pressure has dropped and trap can be comfortably touched with bare hand.
3. Do not drop traps or spare bellows or toss them about.
4. Do not use a Stillson or Monkey wrench to remove or replace bellows or tighten them excessively in trap cover.
5. Do not store, pile or carry bellows with tools and pipe fittings.
6. Most trap operating difficulties and failures are caused by circumstances which the trap cannot control. Some examples are pipe scale, dirt, waterhammer, corrosive condensate, improper installation and inaccessible location. Avoid or correct these detrimental conditions.
7. Ensure to regularly blow down and clean strainers and dirt pockets.

Repair

1. Wait until trap is cool to the touch.
2. Remove cover. Remove and discard old gasket.

3. Remove bellows from cover. Use box or open end wrench if bellows has hexagonal end fitting. If bellows has round valve attached (Types N125, N450 or UMT450), use vise-grip clamping on valve diameter. Do not use pipe wrench on bellows convolutions.
4. Remove valve from bellows if construction allows (Types N125, N450 or UMT450).
5. Remove valve seat from body.
6. Examine bellows by:
 - a. comparing to new bellows.
 - b. immersing in cold and hot water to test bellows travel.
 - c. If bellows are not damaged, reassemble into cover; if damaged, replace. Leave threads of bellows dry, tighten into trap cover snugly, and do not over torque.
7. Examine valve and valve seat.
 - a. Clean with 80 to 150 grit emery. If no wear or wire drawing is present, the valve and seat can be reused; if damaged, replace. Use small amount of anti-seize compound on seat and valve threads. Valve and seat should be torqued for snug fit.
8. Insert new gasket.
9. Reassemble cover using small amount of anti-seize compound on cover threads if trap has screwed cover. If cover is bolted, use anti-seize compound on the bolts.
10. Seating of cover gasket may be checked by installing a pipe plug in outlet of trap and applying 80 psig / 5.52 barg air to inlet. Use soapy water or leak detection fluid. A slight seepage should be acceptable since air can pass through a small opening that steam will not.
11. If possible, test trap before returning it to service. Any pressure within trap range can be used; a simple drip leg will suffice. Valve in trap should close on steam. Leave trap on line long enough for trap to cycle once.

Table 1. Troubleshooting

WHEN THIS HAPPENS	HERE IS WHERE THE TROUBLE MAY BE	AND HERE IS WHAT TO DO
Trap not discharging - cool to touch	1. Condensate not reaching the trap: a. Pipe and fittings between equipment and trap plugged by dirt. b. Strainer clogged by dirt.	a. Remove the obstruction. b. Blow out or clean strainer.
	2. Condensate not passing through trap. a. Trap discharge orifice blocked by dirt. b. Pipe and/or fittings between trap and return man plugged by dirt.	a. Clean trap and install strainer. b. Remove obstruction.
	3. Valve, upstream or downstream, not open or failed in closed position.	Open or repair valve.
	4. Bellows has developed a leak or crack.	Replace the bellows. Check for corrosive condition and, if present, substitute bellows material.
Trap discharging condensate continuously - warm to touch	1. Trap, strainer or piping partially obstructed by dirt.	Remove the obstruction, blow down strainer and clean trap.
	2. Valve, upstream or downstream, not open wide.	Open valve wide.
	3. Trap too small for condensate load.	Add another trap in parallel or replace with larger trap
	4. Condensate load has increased since trap was installed. a. Boiler priming or foaming. b. Leak in submerged coil of equipment. c. Other traps have failed transferring condensate to overloaded trap.	a. Correct the boiler condition. b. Repair leak or replace coil/tube. c. Locate and repair/replace faulty traps.
Trap discharging live steam	1. Trap valve not closing tight a. Scale or dirt between valve and seat. b. Valve or seat, or both, eroded and worn.	a. Clean trap and install strainer. b. Replace valve and seat with a matched set.
	2. Trap has been dropped - bellows misaligned so valve cannot seat.	Replace bellows and inspect trap for other damage.
	3. Mistaking open or leaking by-pass valve for trap leak.	Remove the by-pass if permissible, otherwise close or repair valve.
	4. Bellows damaged by waterhammer.	Replace bellows, eliminate cause of waterhammer.
Slow warm-up or temperature of equipment drained too low	1. Steam pressure too low for temperature required by process. a. Pressure throttled by thermostatically controlled steam supply valve. b. Increased demand for steam throughout the plant. c. Steam piping too small for adequate supply.	a. Check for lowest throttled pressure and increase if feasible. b. Increase boiler capacity if possible. Shut down unneeded equipment. c. Increase steam pressure or replace piping with larger size.
	2. Pressure differential across trap too low. a. Steam pressure less than when trap was installed. b. Return line pressure higher than when the trap was installed.	a. Raise pressure to former level. b. Return main too small. Other traps discharging live steam into return main. Repair or replace faulty traps. Obstruction in return main or discharge piping.
	3. Short circuiting caused by group trapping.	See Installation Step 5.
	4. No cooling leg between equipment and trap, or cooling leg is insulated.	See Installation Step 6.
	5. Trap steam-locked. a. Long horizontal piping between equipment and trap. b. Trap above drain outlet of equipment - no water seal at bottom of riser. c. Siphon-drained equipment - rotary dryers and tilting jacketed kettles.	a. See Installation Step 2. b. See Installation Steps 12 and 13. c. See Installation Step 13.
	6. Apparatus drained by siphon pipe.	Examine siphon for break or leak.

TA Series

Parts Ordering

When corresponding with your local Sales Office about TA Series, always reference the assembly number.

 [SpenceValve.com](https://www.SpenceValve.com)

Emerson

Americas

McKinney, Texas 75069 USA
T +1 800 558 5853
+1 972 548 3574

Europe

Bologna 40013, Italy
T +39 051 419 0611

Asia Pacific

Singapore 128461, Singapore
T +65 6777 8211

Middle East and Africa

Dubai, United Arab Emirates
T +971 4 811 8100

VCIMD-16892-EN © 2021, 2026 Emerson Electric Co. All rights reserved 02/26. Spence is a mark owned by a subsidiary of Emerson Electric Co. The Emerson logo is a trademark and service mark of Emerson Electric Co. All other marks are property of their respective owners.

Neither Emerson nor any of its affiliated entities assume responsibility for the selection, use or maintenance of any product. Responsibility for proper selection, use, and maintenance of any product remains solely with the purchaser and end user.

The contents of this publication are presented for informational purposes only, and while every effort has been made to ensure their accuracy, they are not to be construed as warranties or guarantees, express or implied, regarding the products or services described herein or their use or applicability. All sales are governed by our terms and conditions, which are available upon request. We reserve the right to modify or improve the designs or specifications of such products at any time without notice.

