

February 2024

Spence Type E5 Main Valve



WARNING

Failure to follow these instructions or to properly install and maintain this equipment could result property damage and personal injury or death.

Type E5 main valve must be installed, operated and maintained in accordance with federal, state and local codes, rules and regulations and Emerson instructions.

If the valve vents gas or a leak develops in the system, service to the unit may be required. Failure to correct issue could result in a hazardous condition.

Installation, operation and maintenance procedures performed by unqualified personnel may result in improper adjustment and unsafe operation. Either condition may result in equipment damage or personal injury. Only a qualified person shall install or service the Type E5 main valve.



Figure 1. Type E5 Main Valve

Introduction

Scope of the Manual

This manual provides instructions for the installation, troubleshooting, maintenance, valve setting and parts ordering for Type E5 main valve regulator.

Product Description

The Spence Type E5 Main Valve is pilot-operated, single seated, normally closed design. The valve functions quickly and shuts tight on dead end service. The diaphragm is a balanced Hycar material designed for high lift but low differential pressure.

An external condensation chamber is included in the product. There are no springs in the steam flow path and no stuffing box.

Type E5

Specifications

This section lists the specifications for the Type E5 main valve. Factory specifications are stamped on the nameplate fastened on the regulator at the factory.

<p>Valve Sizes NPS 3/4, 1, 1-1/4, 1-1/2, 2, 2-1/2, 3, 4, 5, 6, 8, 10 and 12 / DN 20, 25, 32, 40, 50, 65, 80, 100, 125, 150, 200, 250 and 300</p> <p>End Connection Styles NPT, CL125, CL150, CL250 and CL300</p> <p>Pressure Rating⁽¹⁾ See Table 1</p> <p>Minimum Differential Pressure⁽¹⁾ 5 psi / 0.34 bar</p> <p>Temperature Rating⁽¹⁾ See Table 1</p>	<p>Rated Flow Coefficient See Table 2</p> <p>Material of Constructions Body: Cast Iron or Cast Steel Stem, Disk and Seat: Stainless steel Gasket: Graphite Diaphragm: Nitrile (NBR) Spring: Steel</p> <p>Approximate Weight See Table 3</p>
--------------------------------------------------------------------------------------------------------------------------------------------------------------------------------------------------------------------------------------------------------------------------------------------------------------------------------------------------------------------------------------------------------------------------------------------------	---------------------------------------------------------------------------------------------------------------------------------------------------------------------------------------------------------------------------------------------------------------------------------------------------------------------------------

1. The pressure/temperature limits in this Instruction Manual and any applicable standard or code limitation should not be exceeded.

Table 1. Type E5 Main Valve Pressure and Temperature Rating

MAIN VALVE MATERIAL	END CONNECTION	PRESSURE RATING		TEMPERATURE RATING	
		psig	bar	°F	°C
Cast Iron	250 NPT	250	17.2	450	232
	CL125	125	8.62	450	232
	CL250	250	17.2	450	232
Cast Steel	300 NPT	300	20.7	600	315
	CL150	150	10.3	500	260
	CL300	300	20.7	600	315

Table 2. Type E5 Main Valve Rated Flow Coefficients

SEAT FACTOR	REGULATOR SIZE, NPS / DN												
	3/4 / 20	1 / 25	1-1/4 / 32	1-1/2 / 40	2 / 50	2-1/2 / 65	3 / 80	4 / 100	5 / 125	6 / 150	8 / 200	10 / 250	12 / 300
Full	7.6	11.7	18.9	27.4	43	67	95	159	258	350	665	1018	1611
Normal	5.7	10.0	13.4	19.8	25	35	59	120	176	228	366	525	952

Table 3. Type E5 Main Valve Approximate Weight

VALVE SIZE		CAST IRON						CAST STEEL			
		NPT		CL125		CL250		CL150		CL300	
NPS	DN	lbs	kg	lbs	kg	lbs	kg	lbs	kg	lbs	kg
3/4	20	23	10	----	----	----	----	----	----	----	----
1	25	24	11	30	14	33	15	35	16	39	18
1-1/4	32	49	22	46	21	49	22	58	26	63	29
1-1/2	40	53	24	58	26	68	31	67	30	74	34
2	50	84	38	90	41	97	44	113	51	120	55
2-1/2	65	----	----	97	44	112	51	130	59	135	61
3	80	----	----	148	67	170	77	210	95	226	103
4	100	----	----	208	95	293	133	307	139	330	150
5	125	----	----	240	109	333	151	335	152	366	166
6	150	----	----	348	158	616	280	560	254	503	274
8	200	----	----	650	295	814	370	795	361	862	392
10	250	----	----	910	414	1130	513	1345	611	1420	645
12	300	----	----	1580	718	1920	872	1990	904	2160	982

Principle of Operation

Regulator

The regulator is operated by initial steam or fluid pressure. It is normally closed, being held so by initial pressure on the disk and by an internal main spring, see Figure 3. When the pilot is opened (see pilot instructions), initial pressure flows through the pilot to the 8B tee. 4A bleed port restricts the flow and pressure builds under the diaphragm and opens the main valve.

Delivery pressure feeds back through the control pipe to the pilot diaphragm. As this pressure approaches a balance with the thrust of the adjusting spring, the pilot throttles the loading pressure. In turn, the main valve takes a position established by the loading pressure where just enough steam flows to maintain the set delivery pressure.

Condensate Chamber

Main valves with large internal volumes or valves used in relatively high pressure or superheat, may require more water than can be condensed from radiation alone. Live steam will rapidly degrade the rubber diaphragm of a Type E5 and generally yield poor control in other main valves. To prevent this from happening, the condensation chamber and the base are primed with water before start-up. As the pilot opens, medium pressure steam flows to the condensation chamber condensing the vapor in the presence of the prime and larger radiational area. The condensate exits the chamber through a No. 5B open elbow directed to the No. 5A restriction elbow in the hood. This condensate collecting under the diaphragm creates a loading pressure which forces the valve open.

Installation



WARNING

Personal injury or system damage may result if this regulator is installed, without appropriate overpressure protection, where service conditions could exceed the limits given in the Specifications section and/or regulator nameplate.

Additionally, physical damage to the regulator may result in personal injury or property damage due to escaping of

accumulated gas. To avoid such injury and damage, install the regulator in a safe location.

Under enclosed conditions or indoors, escaping gas may accumulate and be an explosion hazard. In this case, the vent should be piped outdoors.

For regulator constructions with a spring case vent, the vent should be kept open to permit free flow of gas to the atmosphere. Protect openings against entrance of rain, snow, insects or any other foreign material that may plug the spring case vent or vent line.

All pressure equipment should be installed in a non-seismic area; should not be exposed to fire; and should be protected from thunderbolt (lightning) strikes.

Planning

- Locate the valve in a straight run of horizontal pipe.
- Allow headroom above the valve for access through the blind flange.
- Provide clearance for stem withdrawal underneath.
- Prevent water hammer and erratic operation by installing traps to provide proper drainage before and after the valve and before secondary pressure relief valve or control valve.
- Avoid damaging effects of scale and dirt in the pipe lines by using a strainer as shown in Figure 2.
- Provide a three-valve by-pass to facilitate inspection without interrupting service.
- To eliminate excessive noise and erratic regulation with steam and other compressible fluids, enlarge the delivery pipe size to effect a reasonable flow velocity at the reduced pressure. A tapered transition is recommended.
- If possible, avoid a sharp turn close to the regulator outlet and a bull-headed tee connection to the low pressure main.
- Install initial and delivery pressure gages to indicate performance.
- If the pressure rating of the delivery system or connected equipment is less than the initial steam pressure, provide a safety valve.

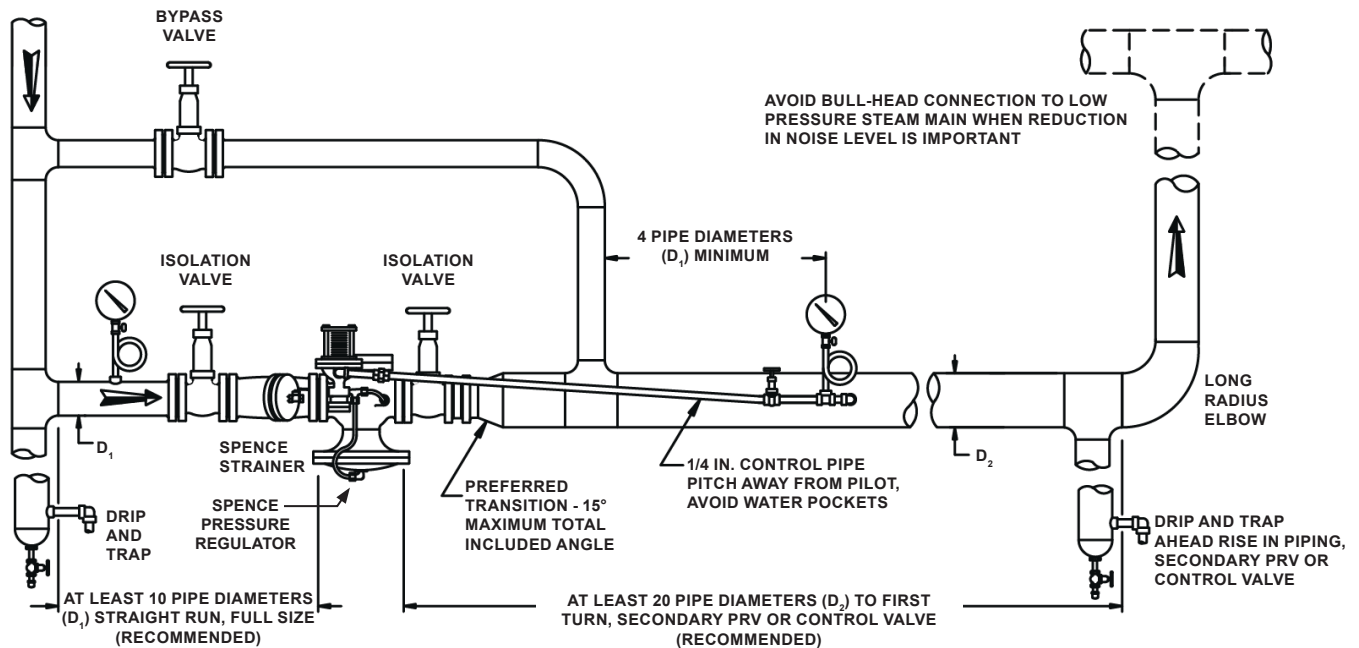

Figure 2. Type E5 Main Valve Installation

Main Valve

- Flush the piping system thoroughly to clear it of welding beads, scale, sand, etc.
- Mount the main valve with diaphragm chamber down and arrow on body pointing in the direction of flow. Screwed end valves should be mounted in unions.

Pilot

For Side Mount Construction

1. Mount the pilot on either side of the main valve by means of 1/4 in. nipple and union provided.
2. Make this connection on the 1/4 in. pipe tap at the inlet of the main valve as shown in Figure 2.

For Integral Mount Construction

1. Remove blind flange on pilot and mount on blind flange of main valve using provided bolt.
2. Screw 4A bleed port fitting into the 1/8 in. pipe tap at the outlet of the main valve body. Note bleed orifice in this fitting is vital to operation of regulator.
3. Screw 8B tee into 1/8 in. pipe tap in pilot. Select tap facing downstream.
4. Screw No. 5B elbow into 1/8 in. pipe tap on underside of main valve diaphragm chamber.
5. Connect tubing bends as illustrated in Figure 3.

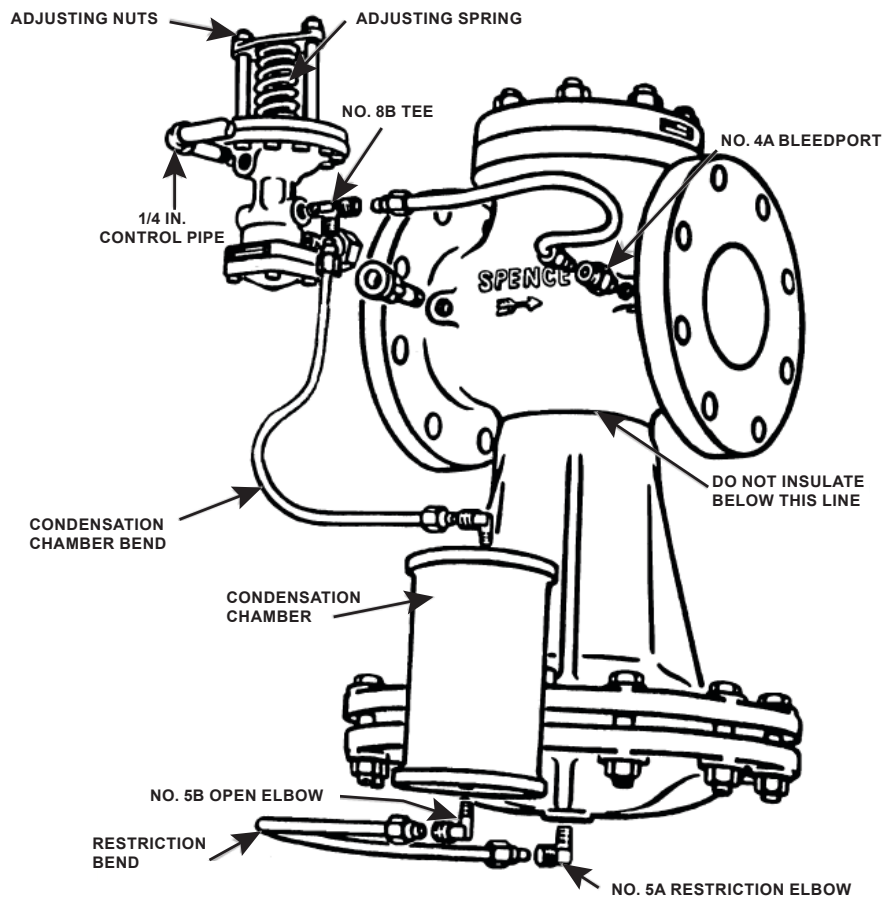

Figure 3. Regulator Assembly for Type E5 Main Valve with Condensation Chamber

Control Pipe (Not required with Types T14 and T52)

1. Use 1/4 in. pipe for the line that connects the pilot diaphragm chamber to the desired point of pressure control.
2. Take the control at a point of minimum turbulence. Avoid control immediately at the valve outlet or after a turn.
3. When the delivery pipe expands in size, select a spot at least 4 in. pipe diameters beyond the point of enlargement.
4. Pitch away from pilot to avoid erratic operation and excessive fouling.
5. Eliminate water pockets.
6. Locate delivery pressure gage in control pipe to show pressure actually reaching pilot diaphragm.

Start-up and Setting



CAUTION

Never open a reducing valve without positive indication that the high side is clear of condensate.

1. On pressure reducing valves like Type E5, use by-pass to fill the delivery system and raise pressure to slightly below normal required.
2. Close pilot by releasing compression on adjusting spring. See Figure 3.
3. Open 1/4 in. control pipe valve.
4. Crack outlet stop valve.
5. Crack inlet stop valve.
6. Blow down strainer.
7. Open inlet stop valve and gradually compress adjusting spring until the valve opens and takes control at desired pressure.
8. Alternately choke down on the by-pass and open outlet stop valve until the regulator is on the line. See individual instructions for other pilots.

Valve Setting

Valve setting is gaged at K to establish correct stem length and diaphragm position. Dimension K is supplied with each replacement stem. See Table 4 for K values.

1. To install new stem (key 13), fasten disk (key 8) firmly on stem with stem nut.
2. Insert stem and disk assembly in valve and screw on pressure plate (key 16). Omit spring (key 14) for this operation.
3. Hold disk on seat and adjust position of pressure plate until valve setting K is reached.
4. Push pressure plate against stops in base (key 18).
5. Remove disc, drop out pressure plate and stem, drill and insert dowel pin (key 15) to lock the joint.
6. Grind off stem projection flush with face of pressure plate.

Troubleshooting

Failure to Open

If the main valve failed to open check the following possible causes to properly correct the problem.

- Adjusting spring on pilot may have been tampered with.
- Initial pressure may be down due to partially closed supply valve, clogged strainer or other obstruction.
- No. 4A bleed port fitting may have been omitted and an open coupling substituted.
- Control pipe may be plugged. Most likely points of obstruction are at shutoff valve and entrance to delivery main.
- Main diaphragm may be broken. Test with air or water before dismantling.

Failure to Close

If the main valve failed to close check the following possible causes to properly correct the problem.

- Adjusting spring on pilot may have been tampered with.
- Orifice in bleed port No. 4A may be plugged.
- By-pass valve may be leaking.
- On pressure regulators like Type E5, the main valve or pilot may be held open by foreign matter in seat.

To determine which valve leaks, follow these steps. Close stop valve and 1/4 in. control pipe valve.

1. Remove bleed port bend so pilot will exhaust to atmosphere.
2. Crack inlet stop valve. Steam will issue from 8B tee.
3. Release compression on adjusting spring to see if pilot closes tight.
4. Open and close several times to wash seat. Steam blowing back from bleed port means main valve disk is held open by foreign matter. Steam may wash the obstruction from the seat if the valve is made to open wide. This can be accomplished, even at light loads, if the control point is beyond the outlet stop valve.
5. Reassemble bleed port bend and place regulator in operation.
6. Slowly open and close outlet stop valve.

Maintenance



WARNING

To avoid personal injury or property damage from sudden release of pressure, isolate the regulator from the pressure system and release all pressure from the pilot and main valve before performing maintenance operations.

Inspection

Under normal conditions, complete dismantling is not recommended.

Check the following after operation. Then, schedule an inspection as required.

1. Inspect for dirt collected at 4A bleed port.
2. Inspect all joints for leakage. Keep bolts tight to avoid any leaks

Main Valve Maintenance (See Figure 5)

1. Connect a source of air or water pressure which can be adjusted by hand to the No. 5B elbow.
2. Apply 30 psi / 2.07 bar to jack valve open and prevent stem from turning while removing stem nuts.
3. Use penetrating oil on the threads.

Seat Ring Maintenance

Note

These joints should be made up with high temperature gasket compound.

1. Remove old compound from body and seat ring with a wire brush.
2. Apply new compound sparingly to both parts, threads and shoulders. Let stand until tacky before assembling.

Grinding In



CAUTION

Seats and discs should never require more than the lightest touch up with very fine (400 grit) grinding compound. Heavy grinding will produce galling, wider seating surface and a groove in the disc, all of which tend to cause leakage.

3. Reface a damaged surface before attempting to grind it in.
4. Grind sparingly.
5. Main stem (key 13, Figure 4) is slotted for rotation with a screwdriver, valve spring (key 14) is omitted from the assembly during grinding.
6. Slip the stem into its normal position.
7. Apply compound to the disc. Place it on the stem and guide plug, tighten with stem nut.
8. After grinding, disassemble and clean all parts.

Parts Ordering

When corresponding with your local Sales Office about Type E5 Main Valve, always reference the assembly number. When ordering replacement parts, specify the complete character part number from the following parts list.

Parts List

Type E5 (NPS 3/4 to 2 / DN 20 to 50)

Key	Description	Part Number
1	Stud (4 required)	
	Cast iron	
	NPS 3/4 / DN 20	WAL05-05518-00
	NPS 1 / DN 25	WAL04-10118-00
	NPS 1-1/4 / DN 32	WAL05-05507-00
	NPS 1-1/2 / DN 40	WAL04-05443-00
	NPS 2 / DN 50	WAL04-10119-00
	Steel	
	NPS 3/4 / DN 20	WAL05-05518-00
	NPS 1 / DN 25	WAL05-05506-00
	NPS 1-1/4 / DN 32	WAL05-05507-00
	NPS 1-1/2 / DN 40	WAL05-05509-00
	NPS 2 / DN 50	WAL05-05510-00

Type E5

Type E5 (NPS 3/4 to 2 / DN 20 to 50) (continued)

Key	Description	Part Number
2	Hex Nut (4 required) Cast iron NPS 3/4 / DN 20 NPS 1 / DN 25 NPS 1-1/4 / DN 32 NPS 1-1/2 / DN 40 NPS 2 / DN 50 Steel NPS 3/4 / DN 20 NPS 1 / DN 25 NPS 1-1/4 / DN 32 NPS 1-1/2 / DN 40 NPS 2 / DN 50	WAL05-02847-00 WAL05-02851-00 WAL05-02854-00 WAL05-02856-00 WAL05-02860-00 WAL05-02848-00 WAL05-02852-00 WAL05-02855-00 WAL05-02857-00 WAL05-02861-00
3	Blind Flange Cast iron NPS 3/4 / DN 20 NPS 1 / DN 25 NPS 1-1/4 / DN 32 NPS 1-1/2 / DN 40 NPS 2 / DN 50 Steel NPS 3/4 / DN 20 NPS 1 / DN 25 NPS 1-1/4 / DN 32 NPS 1-1/2 / DN 40 NPS 2 / DN 50	WAL04-02171-01 WAL04-02173-00 WAL04-02176-00 WAL04-02178-00 WAL04-02180-00 WAL04-02190-00 WAL04-02192-00 WAL04-02194-00 WAL04-02196-00 WAL04-02198-00
4	Gasket, Graphite NPS 3/4 / DN 20 NPS 1 / DN 25 NPS 1-1/4 / DN 32 NPS 1-1/2 / DN 40 NPS 2 / DN 50	WAL05-02381-01 WAL05-02362-01 WAL05-02382-01 WAL05-02365-01 WAL05-02366-01
5	Stem Nut, Steel (2 required) NPS 3/4 / DN 20 NPS 1 and 1-1/4 / DN 25 and 32 NPS 1-1/2 and 2 / DN 40 and 50	WAL05-02969-00 WAL05-02874-00 WAL05-02971-00
6	Muffling Plate, For NPS 2 / DN 50 only	WAL04-03550-01
7	Disk Full Stainless steel NPS 3/4 / DN 20 NPS 1 / DN 25 NPS 1-1/4 / DN 32 NPS 2 / DN 50 Stainless steel, 45%/50% NPS 3/4 / DN 20 NPS 1-1/2 / DN 40 Stainless steel, 70%/75% NPS 1-1/4 / DN 32 NPS 1-1/2 / DN 40 NPS 2 / DN 50 Stellite, For NPS 2 / DN 50 only Soft NPS 3/4 / DN 20 NPS 1-1/2 / DN 40 NPS 2 / DN 50 Normal Stainless steel NPS 3/4 / DN 20 NPS 1 / DN 25 NPS 1-1/4 / DN 32 NPS 1-1/2 / DN 40 NPS 2 / DN 50 Stellite, For NPS 2 / DN 50 only	WAL04-01813-02 WAL04-01832-02 WAL04-01850-02 WAL04-01888-02 WAL04-11884-00 WAL04-11424-00 WAL04-11189-00 WAL04-11916-00 WAL04-11850-00 WAL04-01889-02 WAL05-01715-00 WAL05-01718-00 WAL05-01719-00 WAL04-01808-00 WAL04-01823-02 WAL04-01844-00 WAL04-01862-02 WAL04-01897-02 WAL04-01898-00
8	Seat Ring Full Stainless steel NPS 3/4 / DN 20 NPS 1 / DN 25 NPS 1-1/4 / DN 32 NPS 1-1/2 / DN 40 NPS 2 / DN 50 Stellite, For NPS 2 / DN 50 only Normal Stainless steel NPS 3/4 / DN 20 NPS 1 / DN 25 NPS 1-1/4 / DN 32 NPS 1-1/2 / DN 40 NPS 2 / DN 50 Stellite, For NPS 2 / DN 50 only	WAL04-04075-01 WAL04-04084-01 WAL04-04092-01 WAL04-04496-01 WAL04-11544-00 WAL04-11588-00 WAL04-04069-01 WAL04-04081-01 WAL04-04087-01 WAL04-04095-00 WAL04-11545-00 WAL04-11589-00
9	Pipe Plug, 1/4 NPT	WAL04-03772-00
10	Pipe Plug, 1/8 NPT (2 required)	WAL04-03769-00
11	Stem Side and Integral Mount NPS 3/4 / DN 20 NPS 1 / DN 25 NPS 1-1/4 / DN 32 NPS 1-1/2 / DN 40 NPS 2 / DN 50 Side Mount Balanced NPS 3/4 / DN 20 Internally (406°F / 208°C), Full and Normal Dashpot NPS 1 / DN 25 Internally (406°F / 208°C), Full and Normal Externally (406°F / 208°C), Full Dashpot NPS 1-1/4 / DN 32 Internally (406°F / 208°C), Full and Normal Internally (550°F / 288°C), Full Externally (406°F / 208°C), Full Externally (550°F / 288°C), Full Dashpot NPS 1-1/2 / DN 40 Internally (406°F / 208°C), Full and Normal Externally (406°F / 208°C), Full Dashpot NPS 2 / DN 50 Internally (406°F / 208°C), Full Internally (406°F / 208°C), Normal Internally (550°F / 288°C), Full Externally (406°F / 208°C), Full Externally (550°F / 288°C), Full Dashpot	WAL04-05232-01 WAL04-05242-01 WAL04-05246-01 WAL04-05383-01 WAL04-05265-01 WAL04-05643-00 WAL04-05232-01 WAL04-05644-00 WAL04-11888-00 WAL04-05242-01 WAL04-05645-00 WAL04-05645-00 WAL04-05246-01 WAL04-05246-01 WAL04-05246-01 WAL04-03132-00 WAL04-12288-00 WAL04-05383-01 WAL04-05647-00 WAL04-13917-00 WAL04-05647-00 WAL04-05265-01 WAL04-05265-01 WAL04-05265-01
12	Body Cast iron NPT NPS 3/4 / DN 20 NPS 1 / DN 25 NPS 1-1/4 / DN 32 NPS 1-1/2 / DN 40 NPS 2 / DN 50 BSPT NPS 3/4 / DN 20 NPS 1 / DN 25 NPS 1-1/4 / DN 32 NPS 1-1/2 / DN 40 NPS 2 / DN 50	WAL04-00639-00 WAL04-00640-00 WAL04-00643-00 WAL04-00646-00 WAL04-00649-00 WAL04-15262-00 WAL04-15209-00 WAL04-15263-00 WAL04-15264-00 WAL04-15265-00

Type E5 (NPS 3/4 to 2 / DN 20 to 50) (continued)

Key	Description	Part Number	Key	Description	Part Number
12	Body (continued)		18	Hex Nut (12 required) NPS 3/4 and 1 / DN 20 and 25 NPS 1-1/4 and 1-1/2 / DN 32 and 40	WAL05-02874-00 WAL05-02877-00
	Cast iron (continued)		19	Hood Cast iron NPS 3/4 and 1 / DN 20 and 25 NPS 1-1/4 and 1-1/2 / DN 32 and 40 NPS 2 / DN 50	WAL04-02630-00 WAL04-02629-00 WAL04-02638-00
	CL125 FF NPS 1 / DN 25 NPS 1-1/4 / DN 32 NPS 1-1/2 / DN 40 NPS 2 / DN 50	WAL04-00641-00 WAL04-00644-00 WAL04-00647-00 WAL04-00650-00		Steel NPS 3/4 and 1 / DN 20 and 25 NPS 1-1/4 and 1-1/2 / DN 32 and 40 NPS 2 / DN 50	WAL04-02631-00 WAL04-17996-00 WAL04-02639-00
	CL250 RF NPS 1 / DN 25 NPS 1-1/4 / DN 32 NPS 1-1/2 / DN 40 NPS 2 / DN 50	WAL04-00642-00 WAL04-00645-00 WAL04-00648-00 WAL04-00651-00	20	Diaphragm, Hycar NPS 3/4 and 1 / DN 20 and 25 NPS 1-1/4 and 1-1/2 / DN 32 and 40 NPS 2 / DN 50	WAL05-01600-00 WAL05-01601-00 WAL05-01602-00
	Steel		21	Disk Holder NPS 3/4 / DN 20 NPS 1-1/2 / DN 40 NPS 2 / DN 50	WAL04-02515-00 WAL04-02522-00 WAL04-02525-00
	NPT NPS 3/4 / DN 20 NPS 1 / DN 25 NPS 1-1/4 / DN 32 NPS 1-1/2 / DN 40 NPS 2 / DN 50	WAL04-00670-00 WAL04-00672-00 WAL04-00676-00 WAL04-00687-00 WAL04-00691-00	22	Disk Washer NPS 3/4 / DN 20 NPS 1-1/2 / DN 40 NPS 2 / DN 50	WAL04-06092-01 WAL04-06099-01 WAL04-06102-01
	SWE NPS 3/4 / DN 20 NPS 1 / DN 25 NPS 1-1/4 / DN 32	WAL04-01211-00 WAL04-01212-00 WAL04-01213-00	23	Internal Flange Cast iron NPS 3/4 / DN 20 NPS 1 / DN 25 NPS 1-1/4 / DN 32 NPS 1-1/2 / DN 40 NPS 2 / DN 50	WAL04-17583-00 WAL04-17584-00 WAL04-17585-00 WAL04-17586-00 WAL04-17587-00
	CL150 RF NPS 1 / DN 25 NPS 1-1/4 / DN 32 NPS 1-1/2 / DN 40 NPS 2 / DN 50	WAL04-00673-00 WAL04-00677-00 WAL04-00688-00 WAL04-00692-00		Steel NPS 3/4 / DN 20 NPS 1 / DN 25 NPS 1-1/4 / DN 32 NPS 1-1/2 / DN 40 NPS 2 / DN 50	WAL0A-17999-00 WAL0A-18000-00 WAL0A-18001-00 WAL0A-18002-00 WAL0A-17997-00
	CL300 RF NPS 1 / DN 25 NPS 1-1/4 / DN 32 NPS 1-1/2 / DN 40 NPS 2 / DN 50	WAL04-00674-00 WAL04-00678-00 WAL04-00689-00 WAL04-00693-00	24	Top Adapter	WAL04-17577-00
13	Spring NPS 3/4 and 1 / DN 20 and 25 NPS 1-1/4 and 1-1/2 / DN 32 and 40 NPS 2 / DN 50	WAL05-05072-01 WAL05-05071-01 WAL05-05073-01	26	Piston, Side Mount Balanced NPS 3/4 / DN 20 Internally (406°F / 208°C), Full Internally (406°F / 208°C), Normal Dashpot NPS 1 / DN 25 Internally (406°F / 208°C), Full Internally (406°F / 208°C), Normal Externally (406°F / 208°C), Full Externally (406°F / 208°C), Normal Dashpot NPS 1-1/4 / DN 32 Internally (406°F / 208°C), Full Internally (406°F / 208°C), Normal Internally (550°F / 288°C), Full Externally (406°F / 208°C), Full Externally (406°F / 208°C), Normal Externally (550°F / 288°C), Full Dashpot NPS 1-1/2 / DN 40 Internally (406°F / 208°C), Full Internally (406°F / 208°C), Normal Externally (406°F / 208°C), Full Externally (406°F / 208°C), Normal Dashpot NPS 2 / DN 50 Internally (406°F / 208°C), Full Internally (406°F / 208°C), Normal Internally (550°F / 288°C), Full Externally (406°F / 208°C), Full Externally (406°F / 208°C), Normal Externally (550°F / 288°C), Full Dashpot	WAL04-03336-00 WAL04-11007-00 WAL04-03372-00 WAL04-03337-00 WAL04-10775-00 WAL04-03337-00 WAL04-10775-00 WAL04-03373-00 WAL04-03338-00 WAL04-10778-00 WAL04-03338-00 WAL04-03338-00 WAL04-03338-00 WAL04-10778-00 WAL04-03338-00 WAL04-13931-00 WAL04-03339-00 WAL04-10711-00 WAL04-03339-00 WAL04-10711-00 WAL04-03329-00 WAL04-03340-00 WAL04-11306-00 WAL04-03340-00 WAL04-03340-00 WAL04-11306-00 WAL04-11306-00 WAL04-03340-00 WAL04-03331-00
14	Pin NPS 3/4 and 1 / DN 20 and 25 NPS 1-1/4, 1-1/2 and 2 / DN 32, 40 and 50	WAL05-03245-00 WAL05-03248-00			
15	Cap Screw 1 required NPS 3/4 and 1 / DN 20 and 25 NPS 1-1/4, 1-1/2 and 2 / DN 32, 40 and 50 11 required NPS 3/4 and 1 / DN 20 and 25 NPS 1-1/4, 1-1/2 and 2 / DN 32, 40 and 50	WAL05-04775-00 WAL05-04782-00 WAL05-04774-00 WAL05-04780-00			
16	Base Cast iron NPS 3/4 and 1 / DN 20 and 25 NPS 1-1/4 and 1-1/2 / DN 32 and 40 NPS 2 / DN 50 Steel NPS 3/4 and 1 / DN 20 and 25 NPS 1-1/4 and 1-1/2 / DN 32 and 40 NPS 2 / DN 50	WAL04-00546-00 WAL04-00518-00 WAL04-00521-00 WAL04-01265-00 WAL0A-17986-00 WAL04-03058-00			
17	Pressure Plate NPS 3/4 / DN 20 NPS 1 / DN 25 NPS 1-1/4 / DN 32 NPS 1-1/2 / DN 40 NPS 2 / DN 50	WAL04-03697-00 WAL04-03680-00 WAL04-03698-00 WAL04-03688-00 WAL04-03673-00			

Type E5

Type E5 (NPS 3/4 to 2 / DN 20 to 50) (continued)

Key	Description	Part Number
27	Cylinder, Side Mount Balanced NPS 3/4 / DN 20 Internally (406°F / 208°C), Full Internally (406°F / 208°C), Normal Dashpot NPS 1 / DN 25 Internally (406°F / 208°C), Full Internally (406°F / 208°C), Normal Externally (406°F / 208°C), Full Externally (406°F / 208°C), Normal Dashpot NPS 1-1/4 / DN 32 Internally (406°F / 208°C), Full Internally (406°F / 208°C), Normal Internally (550°F / 288°C), Full Externally (406°F / 208°C), Full Externally (406°F / 208°C), Normal Externally (550°F / 288°C), Full Dashpot NPS 1-1/2 / DN 40 Internally (406°F / 208°C), Full Internally (406°F / 208°C), Normal Externally (406°F / 208°C), Full Externally (406°F / 208°C), Normal Dashpot NPS 2 / DN 50 Internally (406°F / 208°C), Full Internally (406°F / 208°C), Normal Internally (550°F / 288°C), Full Externally (406°F / 208°C), Full Externally (406°F / 208°C), Normal Externally (550°F / 288°C), Full Dashpot	WAL04-01569-01 WAL04-11006-00 WAL04-01549-00 WAL04-01570-01 WAL04-10774-00 WAL04-01570-01 WAL04-10774-00 WAL04-01550-00 WAL04-01571-01 WAL04-10776-00 WAL04-18240-00 WAL04-01571-01 WAL04-10776-00 WAL04-18240-00 WAL04-01551-00 WAL04-01572-01 WAL04-10710-00 WAL04-01572-01 WAL04-10710-00 WAL04-01552-00 WAL04-01573-01 WAL04-11305-00 WAL04-18242-00 WAL04-01573-01 WAL04-11305-00 WAL04-18242-00 WAL04-01553-00
30	Piston O-ring, Side Mount Balanced NPS 3/4 / DN 20 Internally (406°F / 208°C), Full Internally (406°F / 208°C), Normal Dashpot NPS 1 / DN 25 Internally (406°F / 208°C), Full Internally (406°F / 208°C), Normal Externally (406°F / 208°C), Full Externally (406°F / 208°C), Normal Dashpot NPS 1-1/4 / DN 32 Internally (406°F / 208°C), Full Internally (406°F / 208°C), Normal Internally (550°F / 288°C), Full Externally (406°F / 208°C), Full Externally (406°F / 208°C), Normal Externally (550°F / 288°C), Full Dashpot NPS 1-1/2 / DN 40 Internally (406°F / 208°C), Full Internally (406°F / 208°C), Normal Externally (406°F / 208°C), Full Externally (406°F / 208°C), Normal Dashpot NPS 2 / DN 50 Internally (406°F / 208°C), Full Internally (406°F / 208°C), Normal Internally (550°F / 288°C), Full Externally (406°F / 208°C), Full Externally (406°F / 208°C), Normal Externally (550°F / 288°C), Full Dashpot	WAL05-04020-00 WAL05-04011-00 WAL05-04491-00 WAL05-04027-00 WAL05-07967-00 WAL05-04027-00 WAL05-07967-00 WAL05-04492-00 WAL05-16514-00 WAL04-10776-00 WAL05-16514-00 WAL05-16514-00 WAL04-10776-00 WAL05-16514-00 WAL05-04493-00 WAL05-04036-00 WAL05-04028-00 WAL05-04036-00 WAL05-04028-00 WAL05-04494-00 WAL05-04041-00 WAL05-04030-00 WAL05-16509-00 WAL05-04041-00 WAL05-04030-00 WAL05-16509-00 WAL05-04501-00

Type E5 (NPS 3/4 to 2 / DN 20 to 50) (continued)

Key	Description	Part Number
33	Locknut NPS 3/4 / DN 20 NPS 1 and 1-1/4 / DN 25 and 32 NPS 1-1/2 and 2 / DN 40 and 50	WAL05-03015-00 WAL05-03016-00 WAL05-03017-00
36	Gasket, Adapter, Cast iron	WAL05-02378-01
37	Gasket, Adapter, Steel	WAL05-11718-00
38	Hex Nut, Adapter (8 required) Cast iron Steel	WAL05-14888-00 WAL05-02847-00
39	Stud, Adapter, Cast iron (4 required)	WAL05-05490-00
40	Stud, Adapter, Steel (4 required)	WAL05-05518-00
43	Retaining Ring	WAL05-17581-00

Type E5 (NPS 2-1/2 to 12 / DN 65 to 300)

Key	Description	Part Number
1	Stud Cast iron CL125 FF NPS 2-1/2 / DN 65 NPS 3 / DN 80 NPS 4 / DN 100 NPS 5, 6 and 8 / DN 125, 150 and 200 NPS 12 / DN 300 CL250 RF NPS 2-1/2 / DN 65 NPS 3 / DN 80 NPS 4 and 5 / DN 100 and 125 NPS 6 / DN 150 NPS 8 / DN 200 NPS 10 and 12 / DN 250 and 300 Steel, CL150 and 300 RF NPS 2-1/2 / DN 65 NPS 3 and 4 / DN 80 and 100 NPS 6 and 8 / DN 150 and 200	WAL04-10119-00 WAL04-05443-00 WAL04-10119-00 WAL04-10120-00 WAL05-05450-00 WAL04-05448-00 WAL04-10119-00 WAL04-05448-00 WAL04-05449-00 WAL04-05455-00 WAL05-05450-00 WAL05-18820-00 WAL05-05509-00 WAL05-05519-00
2	Hex Nut Cast iron CL125 FF NPS 2-1/2 / DN 65 NPS 3 / DN 80 NPS 4, 5, 6 and 8 / DN 100, 125, 150 and 200 NPS 12 / DN 300 CL250 RF NPS 2-1/2 / DN 65 NPS 3 / DN 80 NPS 4, 5, 6 and 8 / DN 100, 125, 150 and 200 NPS 10 and 12 / DN 250 and 300 Steel, CL150 and 300 RF NPS 2-1/2 / DN 65 NPS 3 / DN 80 NPS 4 / DN 100 NPS 6 and 8 / DN 150 and 200	WAL05-02860-00 WAL05-02856-00 WAL05-02860-00 WAL05-02864-00 WAL05-02862-00 WAL05-02856-00 WAL05-02862-00 WAL05-02864-00 WAL05-02861-00 WAL05-02856-00 WAL05-02857-00 WAL05-02861-00
3	Blind Flange Cast iron CL125 FF NPS 2-1/2 / DN 65 NPS 3 / DN 80 NPS 4 / DN 100 NPS 5 / DN 125 NPS 6 / DN 150 NPS 8 / DN 200 NPS 12 / DN 300 CL150 RF NPS 2-1/2 / DN 65 NPS 3 / DN 80	WAL04-02185-00 WAL04-02157-00 WAL04-02158-00 WAL04-02160-00 WAL04-02165-00 WAL04-02167-00 WAL04-02168-00 WAL04-02183-00 WAL04-02186-00

Type E5 (NPS 2-1/2 to 12 / DN 65 to 300) (continued)

Key	Description	Part Number	Key	Description	Part Number
				Stainless steel, 70%/75%	
				NPS 5 / DN 125	WAL04-11582-00
				NPS 8 / DN 200	WAL04-11926-00
				Soft	
				NPS 4 / DN 100	WAL05-01724-00
				NPS 5 / DN 125	WAL05-01726-00
				NPS 8 / DN 200	WAL05-01729-00
				Normal	
				Stainless steel	
				NPS 2-1/2 / DN 65	WAL04-07072-00
				NPS 3 / DN 80	WAL04-07473-00
				NPS 4 / DN 100	WAL04-07121-00
				NPS 5 / DN 125	WAL04-08245-00
				NPS 6 / DN 150	WAL04-08247-00
				NPS 8 / DN 200	WAL04-02333-00
				Soft, 70%/75%, For NPS 6 / DN 150 only	WAL04-09695-00
			8	Seat Ring	
				Full	
				Stainless steel	
				NPS 2-1/2 / DN 65	WAL04-11539-00
				NPS 3 / DN 80	WAL04-11484-00
				NPS 4 / DN 100	WAL04-11565-00
				NPS 5 / DN 125	WAL04-11700-01
				NPS 6 / DN 150	WAL04-15142-00
				NPS 8 / DN 200	WAL04-15144-00
				NPS 10 / DN 250	WAL04-15146-00
				NPS 12 / DN 300	WAL04-15153-00
				Stainless steel, 45%/50%, For NPS 12 / DN 300 only	WAL04-14845-00
				Stainless steel, 70%/75%	
				NPS 5 / DN 125	WAL04-11700-01
				NPS 8 / DN 200	WAL04-15144-00
				Soft	
				NPS 4 / DN 100	WAL04-11565-00
				NPS 5 / DN 125	WAL04-11700-01
				NPS 8 / DN 200	WAL04-15144-00
				Normal	
				Stainless steel	
				NPS 2-1/2 / DN 65	WAL04-11541-00
				NPS 3 / DN 80	WAL04-11537-00
				NPS 4 / DN 100	WAL04-11567-00
				NPS 5 / DN 125	WAL04-11702-01
				NPS 6 / DN 150	WAL04-15141-00
				NPS 8 / DN 200	WAL04-15143-00
				Soft, 70%/75%, For NPS 6 / DN 150 only	WAL04-15141-00
			9	Pipe Plug, 1/4 NPT (2 required)	WAL04-03772-00
			10	Pipe Plug, 1/8 NPT	WAL04-03769-00
			11	Stem	
				Side Mount Balanced	
				NPS 2-1/2 / DN 65	WAL04-05391-01
				NPS 3 / DN 80	WAL04-05382-01
				NPS 4 / DN 100	
				CL125 FF	WAL04-05281-00
				CL150, 250 and 300 RF	WAL04-05384-01
				NPS 5 / DN 125	
				CL125 FF	WAL04-05287-01
				CL250 RF	WAL04-05386-01
				NPS 6 / DN 150	
				CL125 FF	WAL04-05374-00
				CL150, 250 and 300 RF	WAL04-05385-01
				NPS 8 / DN 200	
				CL125 FF	WAL04-05290-00
				CL150, 250 and 300 RF	WAL04-05388-01
				NPS 10 / DN 250, CL250 RF	WAL04-05295-00
				NPS 12 / DN 300	
				CL250 RF	WAL04-05295-00
				CL300 RF	WAL04-05398-00
				Dashpot, CL250 RF, Full	
				For NPS 5 / DN 125 only	WAL04-05386-01
				Internally Balanced (406°F / 208°C maximum)	
				NPS 8 / DN 200, CL125 FF	WAL04-07564-00
				NPS 12 / DN 300, CL300 RF	WAL04-14838-00
3	Blind Flange (continued)				
	Cast iron, CL150 RF (continued)				
	NPS 4 / DN 100	WAL04-02159-00			
	NPS 5 / DN 125	WAL04-02161-00			
	NPS 6 / DN 150	WAL04-02163-00			
	NPS 8 / DN 200	WAL04-02166-00			
	NPS 10 / DN 250	WAL04-02164-01			
	NPS 12 / DN 300	WAL04-02168-00			
	Steel, CL150 and 300 RF				
	NPS 2-1/2 / DN 65	WAL04-02184-00			
	NPS 3 / DN 80	WAL04-02201-00			
	NPS 4 / DN 100	WAL04-02204-00			
	NPS 6 / DN 150	WAL04-02209-00			
	NPS 8 / DN 200	WAL04-02211-00			
4	Gasket, Graphite				
	NPS 2-1/2 / DN 65	WAL05-02367-01			
	NPS 3 / DN 80	WAL05-02369-01			
	NPS 4 / DN 100	WAL05-02371-01			
	NPS 5 / DN 125	WAL05-02372-01			
	NPS 6 / DN 150	WAL05-02374-01			
	NPS 8 / DN 200	WAL05-02375-01			
	NPS 10 / DN 250	WAL05-02376-01			
	NPS 12 / DN 300	WAL04-02377-01			
5	Stem Nut, Steel (2 required)				
	NPS 2-1/2 / DN 65	WAL05-02972-00			
	NPS 3 / DN 80	WAL05-02973-00			
	NPS 4 / DN 100	WAL05-02974-00			
	NPS 5 / DN 125	WAL04-02975-00			
	NPS 6 / DN 150	WAL04-02976-00			
	NPS 8 and 10 / DN 200 and 250	WAL04-02977-00			
	NPS 12 / DN 300	WAL04-02978-00			
6	Muffling Plate				
	Side Mount, Full				
	NPS 2-1/2 / DN 65	WAL04-03515-00			
	NPS 3 / DN 80	WAL04-03516-00			
	NPS 4 / DN 100	WAL04-03518-00			
	NPS 5 / DN 125	WAL04-03519-00			
	NPS 6 / DN 150	WAL04-03520-00			
	NPS 8 / DN 200	WAL04-03524-00			
	NPS 10 / DN 250	WAL04-03538-00			
	NPS 12 / DN 300	WAL04-03539-00			
	Side Mount, Normal				
	NPS 2-1/2 / DN 65	WAL04-03515-00			
	NPS 3 / DN 80	WAL04-03530-00			
	NPS 4 / DN 100	WAL04-03532-00			
	NPS 5 / DN 125	WAL04-03529-00			
	NPS 6 / DN 150	WAL04-03522-00			
	NPS 8 / DN 200	WAL04-03526-00			
	NPS 10 / DN 250	WAL04-03545-00			
	NPS 12 / DN 300	WAL04-03546-00			
	Internally Balance, Full, For NPS 12 / DN 300 only	WAL04-14846-00			
7	Disk				
	Full				
	Stainless steel				
	NPS 2-1/2 / DN 65	WAL04-01906-01			
	NPS 3 / DN 80	WAL04-01918-00			
	NPS 4 / DN 100	WAL04-01931-00			
	NPS 5 / DN 125	WAL04-01938-00			
	NPS 6 / DN 150	WAL04-01995-00			
	NPS 8 / DN 200	WAL04-01691-00			
	NPS 10 / DN 250	WAL04-01953-00			
	NPS 12 / DN 300	WAL04-01957-00			
	Stainless steel, 45%/50%, For NPS 12 / DN 300 only	WAL04-14839-00			

Type E5

Type E5 (NPS 2-1/2 to 12 / DN 65 to 300) (continued)

Key	Description	Part Number
12	Body	
	Cast iron	
	CL125 FF	
	NPS 2-1/2 / DN 65	WAL04-00653-00
	NPS 3 / DN 80	WAL04-00655-00
	NPS 4 / DN 100	WAL04-00659-01
	NPS 5 / DN 125	WAL04-00661-01
	NPS 6 / DN 150	WAL04-00662-00
	NPS 8 / DN 200	WAL04-00665-00
	NPS 12 / DN 300	WAL04-06618-00
	CL250 RF	
	NPS 2-1/2 / DN 65	WAL04-00652-00
	NPS 3 / DN 80	WAL04-00654-00
	NPS 4 / DN 100	WAL04-00658-01
	NPS 5 / DN 125	WAL04-00660-01
	NPS 6 / DN 150	WAL04-00663-00
	NPS 8 / DN 200	WAL04-00664-00
	NPS 10 / DN 250	WAL04-00666-00
	NPS 12 / DN 300	WAL04-00667-00
	Steel	
	CL150 RF	
	NPS 2-1/2 / DN 65	WAL04-00695-00
	NPS 3 / DN 80	WAL04-00698-00
	NPS 4 / DN 100	WAL04-00704-00
	NPS 6 / DN 150	WAL04-00712-00
	NPS 8 / DN 200	WAL04-00715-00
	CL300 RF	
	NPS 2-1/2 / DN 65	WAL04-00696-00
	NPS 3 / DN 80	WAL04-00699-00
	NPS 4 / DN 100	WAL04-00705-00
	NPS 6 / DN 150	WAL04-00713-00
	NPS 8 / DN 200	WAL04-00716-00
13	Spring	
	NPS 2-1/2 / DN 65	WAL05-05073-01
	NPS 3 / DN 80	WAL05-05047-00
	NPS 4 and 5 / DN 100 and 125	WAL05-05062-00
	NPS 6 and 8 / DN 150 and 200	WAL05-05039-00
	NPS 10 / DN 250	WAL05-05040-01
	NPS 12 / DN 300	WAL05-05079-00
14	Pin	
	NPS 2-1/2 / DN 65	WAL05-03252-00
	NPS 3 and 4 / DN 80 and 100	WAL05-03254-00
	NPS 5 and 6 / DN 125 and 150	WAL05-03258-00
	NPS 8, 10 and 12 / DN 200, 250 and 300	WAL05-03261-00
15	Cap Screw	
	Cast iron	
	CL125 FF	
	1 required	
	NPS 2-1/2 / DN 65	WAL05-04782-00
	NPS 3, 4 and 5 / DN 80, 100 and 125	WAL05-04787-00
	NPS 6 / DN 150	WAL05-04789-00
	NPS 8 / DN 200	WAL05-04791-00
	NPS 12 / DN 300	WAL05-04799-00
	11 required	
	NPS 2-1/2 / DN 65	WAL05-04780-00
	NPS 3 / DN 80	WAL05-04785-00
	NPS 4 and 5 / DN 100 and 125	WAL05-04786-00
	15 required,	
	For NPS 6 and 8 / DN 150 and 200 only	WAL05-04787-00
	19 required, For NPS 12 / DN 300 only	WAL05-04798-00
	CL250 RF	
	1 required	
	NPS 2-1/2 / DN 65	WAL05-04782-00
	NPS 3 / DN 80	WAL05-04787-00
	NPS 4 and 5 / DN 100 and 125	WAL05-04788-00
	NPS 6 and 8 / DN 150 and 200	WAL05-04791-00
	NPS 10 and 12 / DN 250 and 300	WAL05-04799-00

Key	Description	Part Number
15	Cap Screw (continued)	
	Cast iron, CL250 RF (continued)	
	11 required	
	NPS 2-1/2 / DN 65	WAL05-04780-00
	NPS 3 / DN 80	WAL05-04785-00
	NPS 4 and 5 / DN 100 and 125	WAL05-04787-00
	19 required	
	NPS 6 and 8 / DN 150 and 200	WAL05-04788-00
	NPS 10 / DN 250	WAL05-04797-00
	NPS 12 / DN 300	WAL05-04798-00
	Steel	
	CL150 and 300 RF	
	1 required	
	NPS 2-1/2 / DN 65	WAL05-04782-00
	NPS 3 / DN 80	WAL05-04787-00
	NPS 6 / DN 150	WAL05-04791-00
	11 required	
	NPS 2-1/2 / DN 65	WAL05-04780-00
	NPS 3 / DN 80	WAL05-04785-00
	12 required, For NPS 4 / DN 100 only	WAL05-04787-00
	15 required,	
	For NPS 6 and 8 / DN 150 and 200 only	WAL05-04788-00
16	Base	
	Cast iron	
	CL125 FF	
	NPS 2-1/2 / DN 65	WAL04-00548-00
	NPS 3 / DN 80	WAL04-00520-00
	NPS 4 and 5 / DN 100 and 125	WAL04-00515-00
	NPS 6 and 8 / DN 150 and 200	WAL04-00519-01
	NPS 12 / DN 300	WAL04-17453-00
	CL250 RF	
	NPS 2-1/2 / DN 65	WAL04-00548-00
	NPS 3 / DN 80	WAL04-00520-00
	NPS 4 and 5 / DN 100 and 125	WAL04-00522-01
	NPS 6 and 8 / DN 150 and 200	WAL04-00523-01
	NPS 10 / DN 250	WAL04-09142-00
	NPS 12 / DN 300	WAL04-17453-00
	Steel, CL150 and 300 RF	
	NPS 2-1/2 / DN 65	WAL04-03059-00
	NPS 3 / DN 80	WAL0A-17960-00
	NPS 4 / DN 100	WAL0A-17961-00
	NPS 6 and 8 / DN 150 and 200	WAL04-01293-00
17	Pressure Plate	
	NPS 2-1/2 / DN 65	WAL04-03633-00
	NPS 3 / DN 80	WAL04-03681-00
	NPS 4 / DN 100	WAL04-03689-00
	NPS 5 / DN 125	WAL04-03683-00
	NPS 6 / DN 150	WAL04-03685-00
	NPS 8 / DN 200	WAL04-03682-00
	NPS 10 / DN 250	WAL04-03611-00
	NPS 12 / DN 300	WAL04-03690-00
18	Hex Nut	
	NPS 2-1/2 / DN 65	WAL05-02877-00
	NPS 3, 4, 5, 6 and 8	
	/ DN 80, 100, 125, 150 and 200	WAL05-02881-00
	NPS 10 and 12 / DN 250 and 300	WAL05-02883-00
19	Hood	
	Cast iron	
	CL125 FF	
	NPS 2-1/2 / DN 65	WAL04-02638-00
	NPS 3 / DN 80	WAL04-02634-00
	NPS 4 and 5 / DN 100 and 125	WAL04-02626-00
	NPS 6 and 8 / DN 150 and 200	WAL04-18730-00
	NPS 12 / DN 300	WAL04-02637-00
	CL250 RF	
	NPS 2-1/2 / DN 65	WAL04-02638-00
	NPS 3 / DN 80	WAL04-02634-00
	NPS 4 and 5 / DN 100 and 125	WAL04-02633-00
	NPS 6 and 8 / DN 150 and 200	WAL04-02632-01
	NPS 10 / DN 250	WAL04-02628-00
	NPS 12 / DN 300	WAL04-02637-00

Type E5 (NPS 2-1/2 to 12 / DN 65 to 300) (continued)

Key	Description	Part Number
19	Hood (continued)	
	Steel, CL150 and 300 RF	
	NPS 2-1/2 / DN 65	WAL04-02639-00
	NPS 3 / DN 80	WAL04-17962-00
	NPS 4 / DN 100	WAL04-17963-00
	NPS 6 and 8 / DN 150 and 200	WAL04-06269-00
20	Diaphragm, Hycar	
	NPS 2-1/2 / DN 65	WAL05-01602-00
	NPS 3 / DN 80	WAL05-01603-00
	NPS 4 and 5 / DN 100 and 125	WAL05-01604-00
	NPS 6 / DN 150	WAL05-18213-00
	NPS 8 / DN 200	WAL05-01605-00
	NPS 10 / DN 250	WAL05-01606-00
	NPS 12 / DN 300	WAL05-01607-00
21	Disk Holder	
	NPS 4 / DN 100	WAL04-02548-01
	NPS 5 / DN 125	WAL04-02551-00
	NPS 8 / DN 200	WAL04-02537-01
22	Disk Washer	
	NPS 4 / DN 100	WAL04-06119-00
	NPS 5 / DN 125	WAL04-06122-00
	NPS 8 / DN 200	WAL04-06112-01
26	Piston	
	NPS 5 / DN 125	WAL04-03361-00
	NPS 8 / DN 200	WAL04-07253-00
	NPS 12 / DN 300	WAL0A-14848-00
27	Cylinder	
	NPS 5 / DN 125	WAL04-01558-00
	NPS 8 / DN 200	WAL04-07252-01
	NPS 12 / DN 300	WAL04-14875-00
29	Piston Ring, For NPS 5 / DN 125 only	WAL05-04507-00
30	Piston O-ring	
	NPS 8 / DN 200	WAL05-07468-00
	NPS 12 / DN 300	WAL05-14847-00
34	Body O-ring	
	NPS 4 and 5 / DN 100 and 125	WAL05-04528-00
	NPS 6 and 8 / DN 150 and 200	WAL05-04530-00
	NPS 10 and 12 / DN 250 and 300	WAL05-04531-00
35	Piston Spacer, For NPS 12 / DN 300 only	WAL04-14840-00
41	Reducing Bushing,	
	For NPS 10 and 12 / DN 250 and 300 only	WAL05-01109-00
42	Stem Bushing	
	NPS 10 / DN 250	WAL04-02307-00
	NPS 12 / DN 300	WAL04-06528-00
45	Quad Ring, For NPS 8 / DN 200 only	WAL05-07368-00
46	Cap Screw	
	NPS 4 and 5 / DN 100 and 125	WAL05-04808-00
	NPS 8 / DN 200	WAL05-04803-00

Type E5

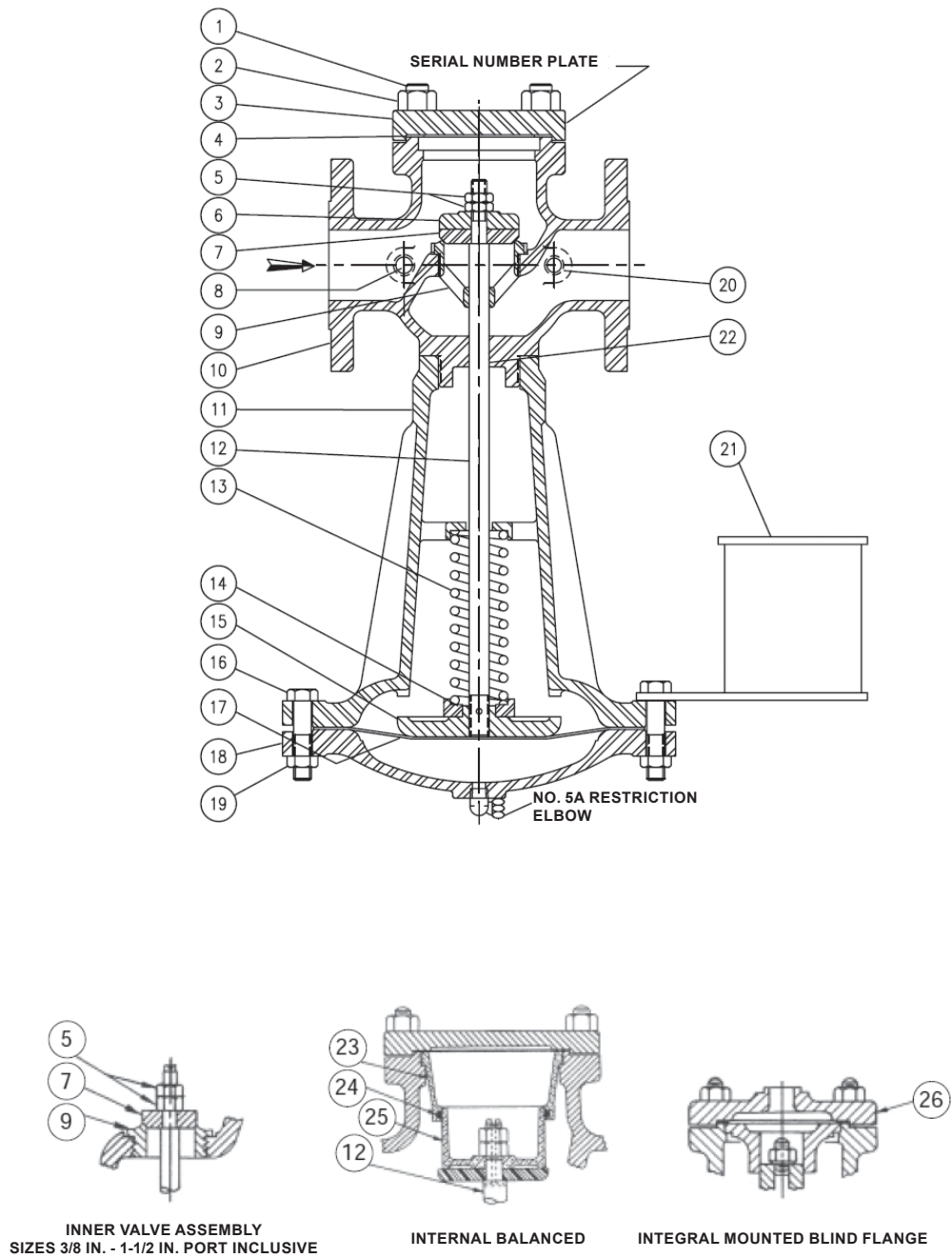

Figure 4. Type E5 Assembly Drawing

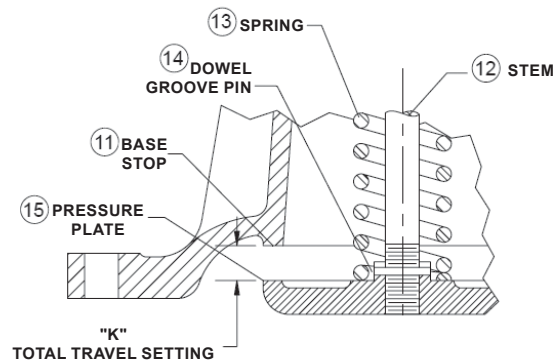

Figure 4. Type E5 Assembly Drawing (continued)

Table 4. Type E5 Main Valve K Values

VALVE SIZE		TYPE E5 TRAVEL SETTING (IN.)		
NPS	DN	Total Travel (K)	Groove Pin	Drill Size
3/4	20	1/4	1/8 x 11/16	1/8
1	25	5/16	1/8 x 11/16	1/8
1-1/4	32	3/8	5/32 x 13/16	5/32
1-1/2	40	7/16	5/32 x 13/16	5/32
2	50	9/16	5/32 x 15/16	5/32
2-1/2	65	11/16	3/16 x 15/16	3/16
3	80	13/16	3/16 X 1-3/8	3/16
4	100	1-1/16	1/4 X 1-3/4	1/4
5	125	1-5/16	5/16 X 1-3/4	5/16
6	150	1-9/16	5/16 X 2	5/16
8	200	2-1/16	3/8 X 2	3/8
10	250	2-9/16	3/8 X 2-1/2	3/8
12	300	3-1/16	1/2 X 2-3/4	1/2

Type E5

 SpenceValve.com

Emerson

Americas

McKinney, Texas 75070 USA
T +1 800 558 5853
+1 972 548 3574

Europe

Bologna 40013, Italy
T +39 051 419 0611

Asia Pacific

Singapore 128461, Singapore
T +65 6777 8211

Middle East and Africa

Dubai, United Arab Emirates
T +971 4 811 8100

VCIMD-14951 © 2021, 2024 Emerson Electric Co. All rights reserved. 02/24
Spence is a mark owned by one of the companies in the Emerson Automation Solutions business unit of Emerson Electric Co. The Emerson logo is a trademark and service mark of Emerson Electric Co. All other marks are property of their prospective owners.

The contents of this publication are presented for informational purposes only, and while every effort has been made to ensure their accuracy, they are not to be construed as warranties or guarantees, express or implied, regarding the products or services described herein or their use or applicability. All sales are governed by our terms and conditions, which are available upon request. We reserve the right to modify or improve the designs or specifications of such products at any time without notice.

Emerson Electric Co. does not assume responsibility for the selection, use or maintenance of any product. Responsibility for proper selection, use and maintenance of any Emerson Electric Co. product remains solely with the purchaser.

