

February 2026

Spence™ NFT250 Series Steam Trap



WARNING

Failure to follow these instructions or to properly install and maintain this equipment could result in an explosion, fire and/or chemical contamination causing property damage and personal injury or death.

NFT250 Series steam trap must be installed, operated and maintained in accordance with federal, state and local codes, rules and regulations and Emerson instructions.

If leak develops in the system, service to the unit may be required. Failure to correct trouble could result in a hazardous condition.

Installation, operation and maintenance procedures performed by unqualified personnel may result in improper adjustment and unsafe operation. Either condition may result in equipment damage or personal injury. Only a qualified person shall install or service the NFT250 Series steam trap.

Introduction

Scope of the Manual

This manual provides instructions for installation, maintenance and parts information for the NFT250 Series.

Product Description

NFT250 Series are float and thermostatic steam traps. Float is free of levers, linkages or other mechanical connections. This float is weighted to maintain orientation and acts as the valve being free to modulate condensate through the seat ring. Air vent is balanced-pressure design with stainless steel welded



Figure 1. NFT250 Series Steam Trap

encapsulated bellows capable of discharging air and non-condensable gases continuously within 15°F / -9.4°C of saturated temperature.

Principle of Operation

On startup, the thermostatic air vent, caged stainless welded bellows, is open, allowing air to flow freely through the vent valve orifice. When condensate flows into the trap, the float rises, allowing condensate to be discharged. Once air and non-condensables have been evacuated, hot condensate will cause the thermostatic vent to close. Condensate will continue to be discharged as long as condensation occurs. During normal operation, an increase in the load causes the liquid level in the trap to rise. The float then rises and rolls off the seat ring, allowing more condensate to flow out. The float sinks as the condensate load decreases, moving nearer to the seat ring, decreasing the effective size of the orifice and allowing less condensate to discharge. This provides smooth, continuous operation that reacts instantly to load variation while maintaining a water seal over the seat ring to prevent live steam loss.

NFT250 Series

Specifications

The specifications section on this page provide the ratings and other specifications for the NFT250 Series.

Available Configurations

- Type **NFT250**: Low capacity
- Type **NFT251**: Medium capacity
- Type **NFT252**: High capacity
- Type **NFT253**: Super high capacity

Body Sizes and End Connection Style

BODY SIZE	END CONNECTION
1/2, 3/4, 1, 1-1/2 and 2 in. / 12.7, 19.1, 25.4, 38.1 and 50.8 mm	NPT
NPS 1-1/2 and 2 / DN 40 and 50	CL250 RF Flanged

Maximum Allowable Pressure⁽¹⁾
250 psig / 17.2 barg

Maximum Operating Pressure⁽¹⁾

See Table 1

Maximum Allowable Temperature⁽¹⁾

450°F / 232°C

Materials of Construction

Body and Cover: Cast Iron ASTM A126B

Cover Gasket: Graphite Fiber

All Internal Parts: Stainless Steel

Air Vent: Stainless Steel

Options

- SLR Orifice
- Blowdown Valve
- Orifice Continuous Bleed Air Vent

1. The pressure/temperature limits in this Instruction Manual and any applicable standard or code limitation should not be exceeded.

Table 1. Maximum Operating Pressure

ORIFICE	MAXIMUM OPERATING PRESSURE	
	psig	barg
20	20	1.4
50	50	3.5
100	100	6.9
150	150	10.3
250	250	17.2

Installation

Install the NFT250 Series steam trap upright and in a horizontal line with the arrow on the body pointing in the direction of flow. Allowable inclination is 5° or less horizontally and 5° or less at right angles to the plane of the pipe line.

Maintenance

Due to normal wear that may occur, inspect the parts periodically and replace if necessary. The frequency of inspection depends on the severity of service conditions.

CAUTION

Inspection of the thermostatic bellows is not recommended as disassembly generally damages the unit.

1. Disassemble the steam trap.
2. Remove the body bolts and place the lower body on a safe place.
3. Inspect the float and lower seat ring for damage and clean or replace as necessary. Clean the float with a rag and steel wool.
4. Clean the screen using a wire brush.
5. Replace bellows if needed. Use needle nose pliers or similar tool. Insert them into two of the

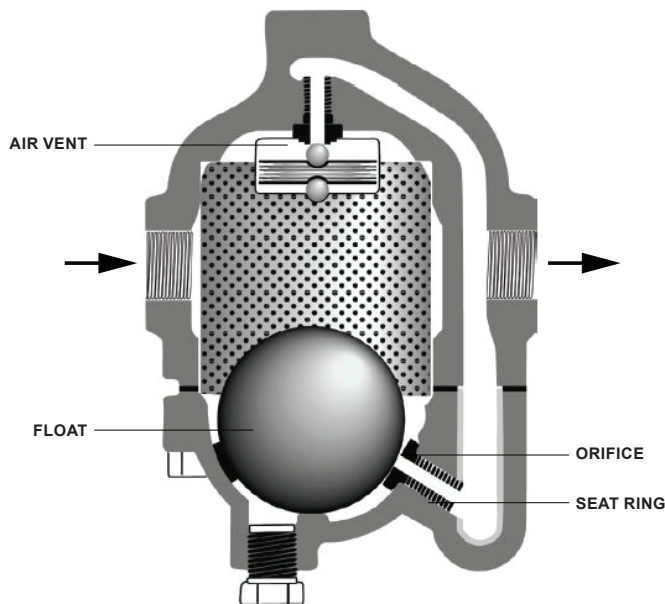

Figure 2. NFT250 Series Steam Trap Operational Schematic

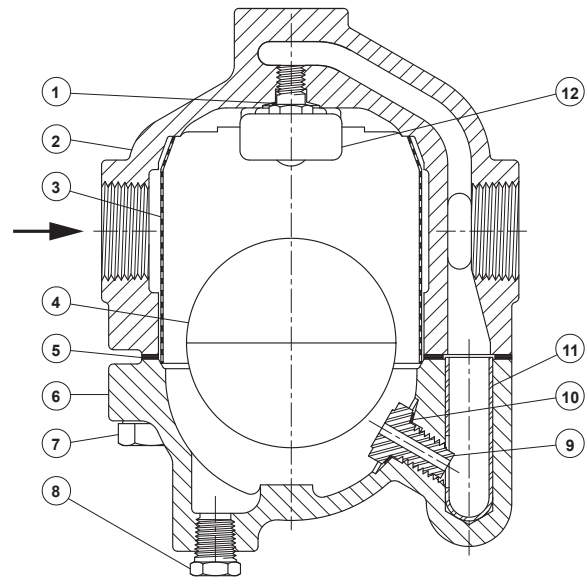

Figure 3. NFT250 Series Steam Trap 1/2 to 2 NPT Assembly

Table 2. NFT250 Series Steam Trap Torque Values

TRAP TYPE	BODY BOLTS		SEAT RING		SEAT RING	
	Ft-lb	N•m	Ft-lb	N•m	In.-lb	N•m
NFT250	25 to 30	33.9 to 40.7	----	----	78 to 84	8.81 to 9.49
NFT251	60 to 70	81.4 to 94.9	----	----	132 to 134	14.9 to 15.1
NFT252	60 to 70	81.4 to 94.9	21.5 to 23.5	29.2 to 31.9	----	----
NFT253	115 to 135	156 to 183	37 to 41	50.2 to 55.6	----	----

three holes located in the bellows assembly and unscrew it from the upper body.

Note

When reassembling, use threadlocker on the bellows assembly threads.

- After inspection or repair, reassemble trap by replacing body gasket and torquing bolts as specified, see Table 2.

Parts Ordering

When corresponding with your local Sales Office about NFT250 Series Steam Trap, always reference the assembly number. When ordering replacement parts specify the complete character part number from the following parts list.

Parts List

Key	Description	Part Number
	Spare Parts Kit	See Table 3
1	Gasket, Air Vent, Copper	WAL05-14599-00
2	Upper Body, Cast Iron NPS 3/4 / DN 20 NPS 1 / DN 25	WAL04-14604-00 WAL04-14606-00
3	Screen, 304 Stainless steel	WAL05-14609-00
4	Float, 17-7 Stainless steel	WAL05-16149-00
5	Gasket, Body, Graphite	WAL05-13403-00
6	Lower Body, Cast Iron	WAL04-14605-00
7	Bolt, Body, Steel (4 required)	WAL05-14649-00
8	Pipe Plug, 1/4 NPT, Steel (2 required)	WAL04-03772-00
9	Seat Ring, 416 Stainless steel 20 psi / 1.4 bar 50 psi / 3.5 bar 100 psi / 6.9 bar 150 psi / 10.3 bar 250 psi / 17.2 bar	WAL04-14613-00 WAL04-15694-00 WAL04-14612-00 WAL04-15690-00 WAL04-14611-00
10	Gasket, Seat Ring, Copper	WAL05-14614-00
11	Sleeve, 316 Stainless steel	WAL05-14610-00
12	Air Vent, Stainless steel	WAL05-14603-00

NFT250 Series

Table 3. NFT250 Series Spare Parts Kit

NFT TRAP MODEL	REPAIR KIT ⁽¹⁾⁽²⁾	PCA SEAT KIT ⁽³⁾	AIR VENT KIT ⁽⁴⁾⁽⁵⁾	GASKET KIT ⁽⁶⁾
NFT250-20	WAL5590110	WAL5590111	WAL33379	WAL5590012
NFT250-50	WAL5590210			WAL5590211
NFT250-100	WAL5590410			WAL5590411
NFT250-150	WAL5590510			WAL5590511
NFT250-250	WAL5590710			WAL5590711
NFT251-20	WAL5590130	WAL5590131	WAL33385	WAL5590032
NFT251-50	WAL5590230			WAL5590231
NFT251-100	WAL5590430			WAL5590431
NFT251-150	WAL5590530			WAL5590531
NFT251-250	WAL5590730			WAL5590731
NFT252-20	WAL5590150	WAL5590151	WAL33390	WAL5590052
NFT252-50	WAL5590250			WAL5590251
NFT252-100	WAL5590450			WAL5590451
NFT252-150	WAL5590550			WAL5590551
NFT252-250	WAL5590750			WAL5590751
NFT253-20	WAL5590170	WAL5590171	WAL33395	WAL5590072
NFT253-50	WAL5590270			WAL5590271
NFT253-100	WAL5590470			WAL5590471
NFT253-150	WAL5590570			WAL5590571
NFT253-250	WAL5590770			WAL5590771

1. Includes body gasket/s, air vent, air vent gasket, seat, seat gasket, screen, screen cap, float, tag and IOM.
2. For repair kit option, add "-SLR" to the end of the part number for the Steam Lock Release option.
3. Includes body gasket/s, seat, seat gasket, tag and IOM.
4. Includes body gasket/s, air vent, air vent gasket, tag and IOM.
5. Air vent tool part number is 04-15832-01.
6. Includes one body gasket. Some kits may include two gaskets as a kit for one NFT trap.

 SpenceValve.com

Emerson

Americas
 McKinney, Texas 75069 USA
 T +1 800 558 5853
 +1 972 548 3574

Europe
 Bologna 40013, Italy
 T +39 051 419 0611

Asia Pacific
 Singapore 128461, Singapore
 T +65 6777 8211

Middle East and Africa
 Dubai, United Arab Emirates
 T +971 4 811 8100

VCIMD-14913-EN © 2021, 2026 Emerson Electric Co. All rights reserved 02/26. Spence is a mark owned by a subsidiary of Emerson Electric Co. The Emerson logo is a trademark and service mark of Emerson Electric Co. All other marks are property of their respective owners.

Neither Emerson nor any of its affiliated entities assume responsibility for the selection, use or maintenance of any product. Responsibility for proper selection, use, and maintenance of any product remains solely with the purchaser and end user.

The contents of this publication are presented for informational purposes only, and while every effort has been made to ensure their accuracy, they are not to be construed as warranties or guarantees, express or implied, regarding the products or services described herein or their use or applicability. All sales are governed by our terms and conditions, which are available upon request. We reserve the right to modify or improve the designs or specifications of such products at any time without notice.

