

April 2022

M Series Solenoid Pilot



WARNING

Failure to follow these instructions or to properly install and maintain this equipment could result property damage and personal injury or death.

The Solenoid Pilot must be installed, operated and maintained in accordance with federal, state and local codes, rules and regulations and Emerson instructions.

Installation, operation and maintenance procedures performed by unqualified personnel may result in improper adjustment and unsafe operation. Either condition may result in equipment damage or personal injury. Only a qualified person shall install or service the Solenoid Pilot.

Introduction

Scope of the Manual

This manual provides instructions for the operation, installation, troubleshooting, maintenance, and parts ordering for M Series Solenoid Pilot.

Product Description

The M Series are epoxy encapsulated solenoids. The green solenoid with lead wires and 1/2 in. / 12.7 mm conduit connection.

See Temperature Limitations section for solenoid identification and nameplate/retainer for service. When M Series is installed just as a solenoid and not attached to a Spence valve, the core has a 0.250-28UNF- 2B tapped hole, 0.38 minimum full thread.

General purpose solenoids (green) are available in open-frame construction. This construction may be supplied with 1/4 in. / 6.35 mm spade, screw or DIN terminals (See Figure 2).



Figure 1. M Series Solenoid Pilot

Optional Features for Type 1 - General Purpose Construction Only

Junction Box - This junction box construction meets Enclosure Types 2, 3, 3S 4, and 4X. Only solenoids with 1/4 in. / 6.35 mm spade or screw terminals may have a junction box. The junction box provides a 1/2 in. / 12.7 mm conduit connection, grounding and spade or screw terminal connections within the junction box (See Figure 3).

DIN Plug Connector Kit No. K236034 - Use this kit only for solenoids with DIN terminals. The DIN plug connector kit provides a two pole with grounding contact DIN Type 43650 construction. (See Figure 4).

M Series

Specifications

This section lists the specifications for the M Series. Factory specifications are stamped on the nameplate fastened on the unit at the factory.

<p>Available Configuration See Table 1</p> <p>End Connection Style CL125 and CL250</p> <p>Maximum Pressure⁽¹⁾ See Table 2</p> <p>Maximum Temperature⁽¹⁾ See Table 2</p>	<p>Materials of Construction Body: Brass Head: Aluminum and polypropylene Internal Core Assembly: Ferrous and brass Bonnet Gasket: Ethylene propylene (EPDM)</p> <p>Applications Remote Electronic Shutoff of Regulators</p> <p>Approximate Weight CL125: 3 lbs / 1.4 kg CL250: 6 lbs / 2.7 kg</p>
---	---

1. The pressure/temperature limits in this Instruction Manual and any applicable standard or code limitation should not be exceeded.

Table 1. M Series Available Configurations

TYPE	NUMBER OF PORTS	OPERATION	APPLICATION
M24	3-way	Normally open	for cold fluids in straight solenoid valve
M25	3-way	Normally closed	for cold fluids in straight solenoid valve
M26	2-way	Normally open	for cold fluids in multiple pilot arrangements
M27	2-way	Normally closed	for cold fluids in multiple pilot arrangements
M32 ⁽¹⁾	2-way	Normally open	for steam or other hot fluid services in multiple pilot arrangements
M33 ⁽¹⁾	2-way	Normally closed	for steam or other hot fluid services in multiple pilot arrangements
M34 ⁽¹⁾	3-way	Normally open	for steam or other hot fluid services in straight solenoid valve
M35 ⁽¹⁾	3-way	Normally closed	for steam or other hot fluid services in straight solenoid valve

1. Add LP suffix for low pressure and HP suffix for high pressure.

Table 2. M Series Pressure and Temperature Ratings

TYPE	MAXIMUM PRESSURE		MAXIMUM TEMPERATURE	
	psig	bar	°F	°C
M24, M25	250	17.2	200	93.3
M26, M27	125	8.6	180	82.2
M32LP, M33, M34LP, M35LP	125	8.6	363	178
M32HP, M33HP, M34HP	250	17.2	406	208

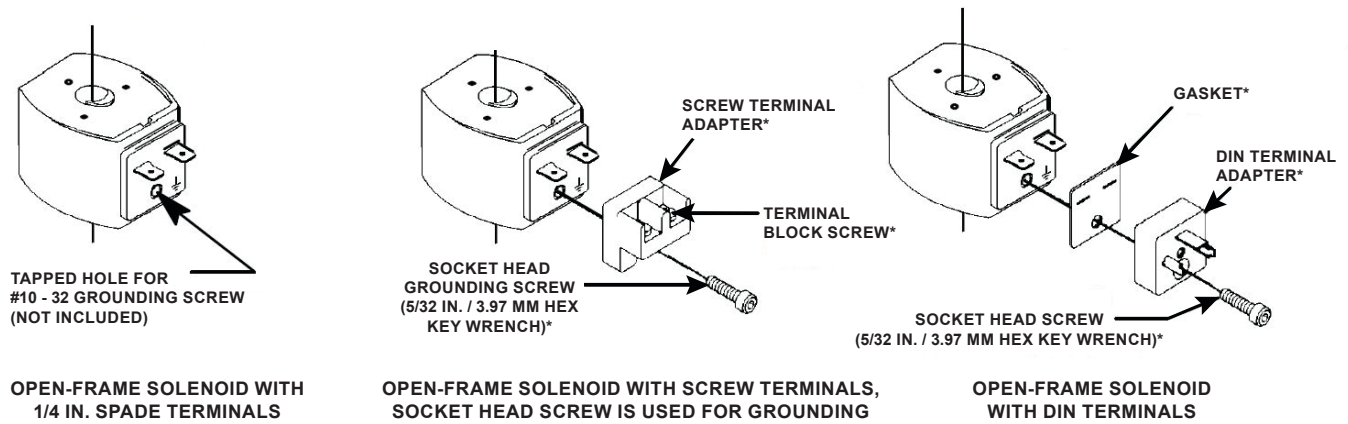

* INDICATES PARTS SUPPLIED IN TERMINATION MODULE KIT NO. K256104

Figure 2. Open-frame Solenoids

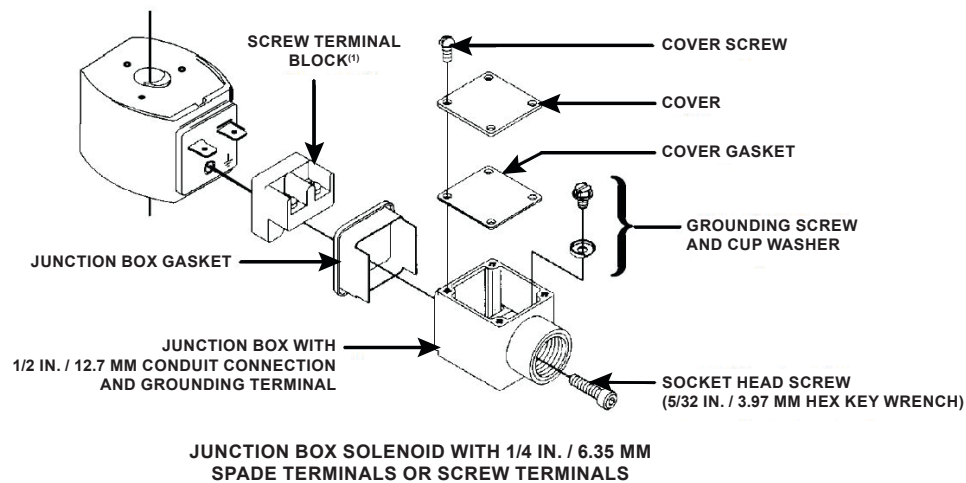

1. Junction box with screw terminals shown. With screw terminal block removed, remaining parts comprise the junction box for spade terminal construction.

Figure 3. Junction Box (Optional Feature)

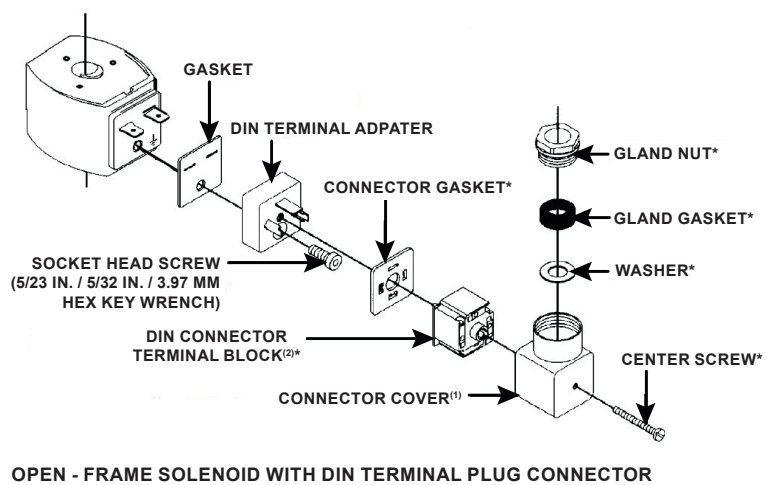

* INCLUDED IN DIN PLUG CONNECTOR KIT NO. K236034

1. Connector cover may be rotated in 90° increments from position shown for alternate position of cable entry.
2. Refer to markings on din connector for proper electrical connections.

Figure 4. DIN Plug Connector Kit No. K236034 (Optional Feature)

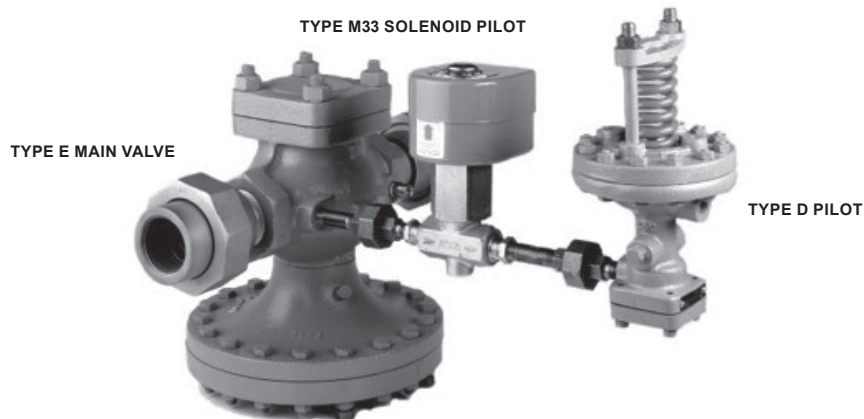

Figure 5. M Series Installation

Principle of Operation

Direct Acting Solenoid Pilot - When the solenoid is energized, the core is drawn into the solenoid base sub-assembly.

Note

When the solenoid is de-energized, the initial return force for the core, whether developed by spring, pressure or weight, must exert a minimum force to overcome residual magnetism created by the solenoid. Minimum return force 1 lb / 12 oz.

Reverse Acting Solenoid Pilot - When the solenoid is energized, the disk holder assembly seats against the orifice.

Note

Initial return force for the disk or disk holder assembly, whether developed by spring, pressure, or weight, must exert a minimum force to overcome residual magnetism created by the solenoid. Minimum return force is 1 lb / 12 oz. When the solenoid is de-energized, the disk holder assembly returns.

Installation



WARNING

Electrical hazard from the accessibility of live parts. To prevent the possibility of death, serious injury or property damage, install the open - frame solenoid in an enclosure.

To prevent fire or explosion, do not install solenoid and/or valve where ignition temperature of hazardous atmosphere is less than 356°F / 180°C.

Note

Block enclosure solenoids have an internal non-resetable thermal fuse to limit solenoid temperature in the event that extraordinary conditions occur which could cause excessive temperatures. These conditions include high input voltage, a jammed core, excessive ambient temperature or a shorted solenoid, etc. This unique feature is standard on solenoids with black explosion proof/dust-ignition proof enclosures (Types 7 and 9).

Product Verification

Check nameplate for correct catalog number, service and wattage. Check front of solenoid for voltage and frequency.

Strainer or Filter Requirement

Note

To protect the solenoid valve or operator, install a strainer or filter, suitable for the service involved in the inlet side as close to the valve or operator as possible. Clean periodically depending on service conditions.

Table 3. Temperature Limitations for M Series Solenoids for Use on Valves Rated at 16.1 or 20.1 Watts

WATT RATING	CATALOG NUMBER COIL PREFIX	CLASS OF INSULATION	MAXIMUM AMBIENT TEMPERATURE
16.1	None, KF, KP, SD, SF and SP	F	52°C / 125°F
20.1	FB, KF, KP, SD, SF and SP	F	40°C / 104°F
16.1	None, KB, KH, SS, ST and SU	H	60°C / 140°F 52°C / 125°F (for steam service)
20.1	B, KH, SS, ST, SU and SV	H	60°C / 140°F Not for steam service

Note:
For steam service, refer to Wiring section, Junction Box for temperature rating of supply wires.

Temperature Limitations

For maximum valve ambient temperatures, refer to chart. The temperature limitations listed, only indicate maximum application temperatures for field wiring rated at 194°F / 90°C. Check catalog number prefix and watt rating on nameplate to determine maximum ambient temperature. See valve installation and maintenance instructions for maximum fluid temperature.

Positioning

This solenoid is designed to perform properly when mounted in any position. However, for optimum life and performance, the solenoid should be mounted vertically and upright to reduce the possibility of foreign matter accumulating in the solenoid base sub-assembly area.

Wiring



WARNING

To reduce the risk of electrocution, fire, or property damage, wiring must comply with local codes and the National Electrical Code.

The solenoid must be grounded with grounding wire (if included) or rigid metallic conduit - do not rely on pipe as ground.

All solenoids supplied with lead wires are provided with a grounding wire which is green or green with yellow stripes and a 1/2 in. / 12.7 mm conduit connection.

To facilitate wiring, the solenoid may be rotated 360°. For explosion proof solenoid version, the conduit lead wires are factory sealed for use in hazardous locations.

Note

Cryogenic Applications - Solenoid lead wire insulation should not be subjected to cryogenic temperatures. Adequate lead wire protection and routing must be provided.

Additional Wiring Instructions For Optional Features

Open-Frame solenoid with 1/4 in. spade terminals: For solenoids supplied with screw terminal connections, use #12 to 18.

AWG stranded copper wire rated at 194°F / 90°C or greater. Torque terminal block screws to 10 ± 2 in-lbs / 1.1 ± 0.2 N•m. A tapped hole is provided in the solenoid for grounding, use a #10 to 32 machine screw. Torque grounding screw to 15 to 20 in-lbs / 1.7-2.3 N•m. On solenoids with screw terminals, the socket head screw holding the terminal block to the solenoid is the grounding screw. Torque the screw to 15 to 20 in-lbs / 1.7-2.3 N•m with a 5/32 in. / 3.97 mm hex key wrench.

Junction Box

The junction box is used with spade or screw terminal solenoids only and is provided with a grounding screw and a 1/2 in. / 12.7 mm conduit connection. Connect #12 to 18 AWG standard copper wire only to the screw terminals. Within the junction box use field wire that is rated 194°F / 90°C or greater for connections. For steam service use 221°F / 105°C rated wire up to 50 psi / 3.45 bar or use 257°F / 125°C rated wire above 50 psi / 3.45 bar. After electrical hookup, replace cover gasket, cover, and screws. Tighten screws evenly in a criss-cross manner.

M Series

Table 4. M Series Torque Values

PART NAME	TORQUE VALUE	
	In-lbs	N•m
Solenoid base sub-assembly and adapter	175 ± 25	19.8 ± 2.8
Terminal block screws	10 ± 2	1.1 ± 0.2
Socket head screw	15 to 20	1.7 to 2.3
Center screw	5 ± 1	0.6 ± 0.1

DIN Plug Connector Kit No. K236034

1. The open-frame solenoid is provided with DIN terminals to accommodate the plug connector kit.
2. Remove center screw from plug connector. Using a small screwdriver, pry terminal block from connector cover.
3. Use #12 to 18 AWG stranded copper wire rated at 194°F / 90°C or greater for connections. Strip wire leads back approximately 1/4 in. / 6.35 mm for installation in socket terminals. The use of wire-end sleeves is also recommended for these socket terminals. Maximum length of wire-end sleeves to be approximately 1/4 in. / 6.35 mm Tinning of the ends of the lead wires is not recommended.
4. Thread wire through gland nut, gland gasket, washer and connector cover.

Note

Connector housing may be rotated in 90° increments from position shown for alternate positioning of cable entry.

5. Check DIN connector terminal block for electrical markings. Then make electrical hookup to terminal block according to markings on it. Snap terminal block into connector cover and install center screw.
6. Position connector gasket on solenoid and install plug connector. Torque center screw to 5 ± 1 in-lbs / 0.6 ± 1.1 N•m.

Installation of Solenoid

Solenoids may be assembled as a complete unit. Tightening is accomplished by means of a hex flange at the base of the solenoid.

Solenoid Temperature

Standard solenoids are designed for continuous duty service. When the solenoid is energized for a long period, the solenoid becomes hot and can be touched by hand only for an instant. This is the safe operating temperature.

Maintenance



To prevent the possibility of death, serious injury or property damage, turn off electrical power, de-pressurize solenoid operator and/or valve, and vent fluid to a safe area before servicing.

Verify solenoid is grounded with grounding wire or rigid metallic conduit - do not rely on pipe as ground

Cleaning

All solenoid operators and valves should be cleaned periodically. The time between cleaning will vary depending on medium and service conditions. In general, if the voltage to the solenoid is correct, sluggish valve operation, excessive noise or leakage will indicate that cleaning is required. Clean strainer or filter when cleaning the valve.

Preventive Maintenance

- Keep the medium flowing through the solenoid operator or valve as free from dirt and foreign material as possible.
- Periodic exercise of the valve should be considered if ambient or fluid conditions are such that corrosion, elastomer degradation, fluid contamination build up, or other conditions that could impede solenoid valve shifting, are possible. The actual frequency of exercise necessary will depend on specific operating conditions. A successful operating history is the best indication of a proper interval between exercise cycles.
- Depending on the medium and service conditions, periodic inspection of internal valve parts for damage or excessive wear is recommended. Thoroughly clean all parts. Replace any worn or damaged parts.

Solenoid Replacement (Refer to Figure 6)

1. Disconnect conduit, coil leads and grounding wire.

Note

Any optional parts attached to the old solenoid must be reinstalled on the new solenoid. For removal or assembly of optional parts, see Figures 2, 3 or 4.

2. Snap off red cap from the top of the solenoid base sub-assembly.
3. Push down on solenoid. Then using a suitable screwdriver, insert blade between solenoid and nameplate/retainer. Pry up slightly and push to remove.
4. Remove solenoid spacer and solenoid from solenoid base sub-assembly.
5. Reassemble in reverse order of disassembly.

Troubleshooting

- Faulty Control Circuit - Check the electrical system by energizing the solenoid. A metallic click signifies that the solenoid is operating. Absence of the click indicates loss of power supply. Check for loose or blown fuses, open-circuited or grounded solenoid, broken lead wires or splice connections.
- Burned-Out Solenoid - Check for open-circuited solenoid. Replace if necessary. Check supply voltage; it must be the same as specified on nameplate/retainer and marked on the solenoid. Check ambient temperature and check that the core is not jammed.
- Low Voltage - Check voltage across the terminals. Voltage must be at least 85% of the rated voltage.

Disassembly and Reassembly

1. Remove solenoid, see Solenoid Replacement.
2. Remove spring washer from solenoid base sub-assembly.
3. Unscrew solenoid base sub-assembly from valve body. For reverse-acting solenoids, a special wrench adapter for the solenoid base sub-assembly is supplied in the ASCO Rebuild Kit. For wrench adapter only, order Wrench Kit No. K218950.
4. Remove internal solenoid parts for cleaning or replacement. Use exploded views for identification and placement of parts.
5. If the solenoid is part of a valve, refer to basic valve installation and maintenance instructions for further disassembly.
6. Reassemble in reverse order of disassembly. Use exploded views for identification and placement of parts.
7. Torque solenoid base sub-assembly and adapter to 175 ± 25 in-lbs / 19.8 ± 2.8 N•m.

Parts Ordering

When corresponding with your local Sales Office about this equipment, always reference the service and serial number. Also specify voltage and frequency.

M Series

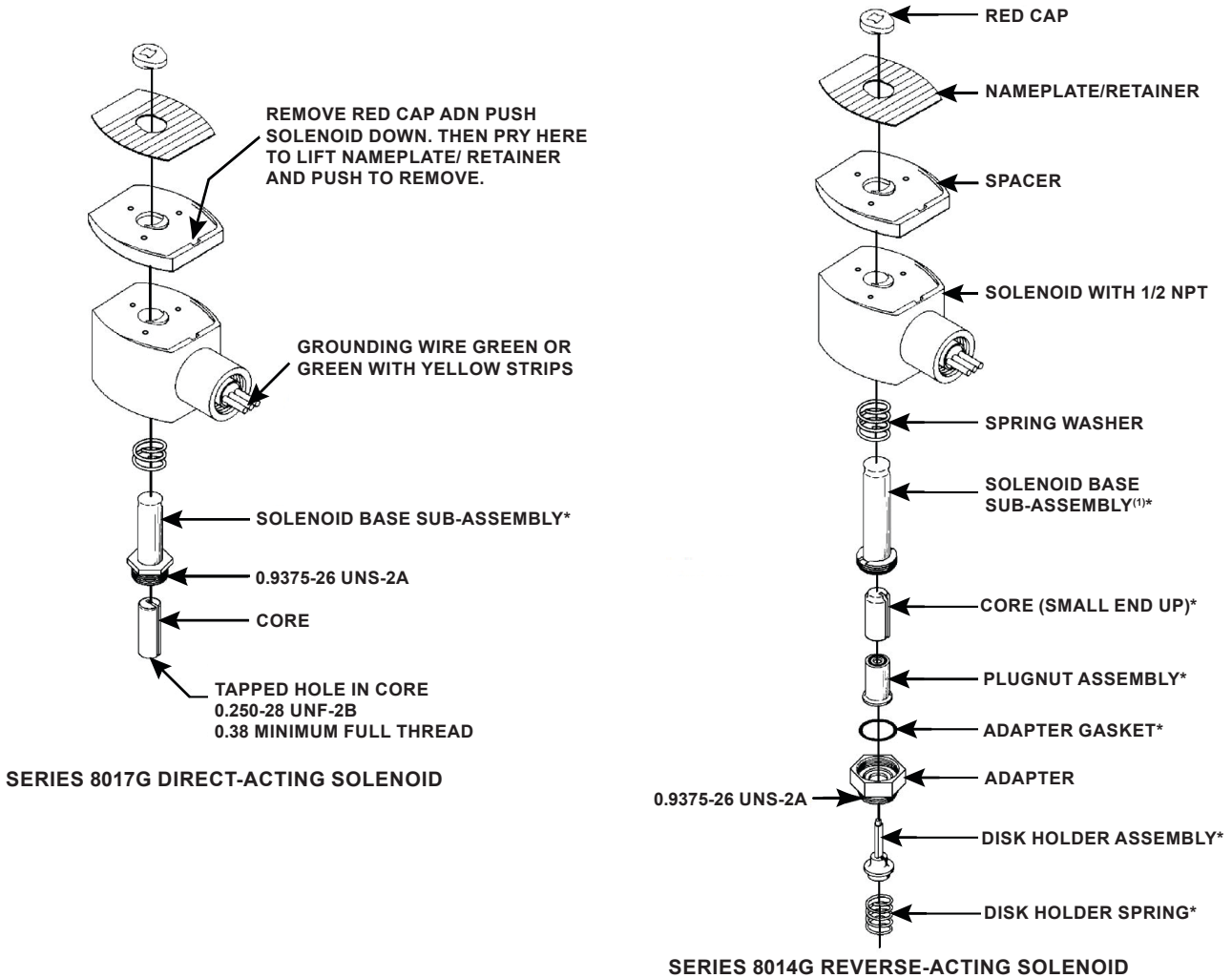

* INDICATES THAT THESE PARTS ARE INCLUDED IN ASCO REBUILD KIT

1. Special wrench adapter supplied in ASCO Rebuild Kit. For wrench kit only, order no. K218950.

Figure 6. M Series Assembly

SpenceValve.com

Emerson Automation Solutions

Americas

McKinney, Texas 75070 USA
T +1 800 558 5853
+1 972 548 3574

Europe

Bologna 40013, Italy
T +39 051 419 0611

Asia Pacific

Singapore 128461, Singapore
T +65 6777 8211

Middle East and Africa

Dubai, United Arab Emirates
T +971 4 811 8100

VCIMD-17076 © 2022 Emerson Process Management Regulator Technologies, Inc. All rights reserved. 04/22. The Emerson logo is a trademark and service mark of Emerson Electric Co. All other marks are the property of their prospective owners. Spence is a mark owned by one of the companies in the Emerson Automation Solutions a business unit of Emerson Electric Co.

The contents of this publication are presented for informational purposes only, and while every effort has been made to ensure their accuracy, they are not to be construed as warranties or guarantees, express or implied, regarding the products or services described herein or their use or applicability. All sales are governed by our terms and conditions, which are available upon request. We reserve the right to modify or improve the designs or specifications of such products at any time without notice.

Emerson Process Management Regulator Technologies, Inc does not assume responsibility for the selection, use or maintenance of any product. Responsibility for proper selection, use and maintenance of any Emerson Process Management Regulator Technologies, Inc. product remains solely with the purchaser.

