

February 2026

## Spence™ Condensate Recovery Pump Trap



*Figure 1. Condensate Recovery Pump Trap*

### Introduction

Condensate Recovery Pump Trap is a pressure operated pump primarily intended to trap or pump condensate depending on pipeline conditions without the use of electricity, that makes it the preferred choice for remote or hazardous locations.

### Features

- **No Electricity Needed** - Uses pressurized steam as the pumping force. Preferable for remote or hazardous locations.
- **Rugged Mechanism** - Unaffected by turbulence. Only operates when needed. No sensors required.
- **Low Profile** - Compact pump trap module.
- **Suitable for a Wide Variety of Liquids** - Condensate from steam systems. Ideal in a sump or other submersible applications where high capacity condensate removal is required.
- **Minimal Installation Space Required** - Mechanism operates with a little as 8 in. / 203 mm installation head from the base of the pump.

# Condensate Recovery Pump Trap

## Specifications

The Specifications section gives some general specifications for the Condensate Recovery Pump Trap.

<b>Body Sizes</b> NPS 1-1/2 x 1 / DN 40 x 25	<b>Limiting Conditions</b> <b>Pump Discharge:</b> 1.3 gal / 5.0 L <b>Maximum Trapping Capacity:</b> 10,021 lbs/hr / 4545 kg/hr <b>Maximum Pumping Capacity:</b> 3075 lbs/hr / 1395 kg/hr
<b>End Connection Style</b> NPT and BSPT	<b>Capacity Information</b> See Table 1 and 2
<b>Maximum Allowable Pressure<sup>(1)</sup></b> 230 psig / 15.9 bar	<b>Construction Materials</b> <b>Body and Cover:</b> SG Iron <b>Gasket:</b> AF-159
<b>Maximum Operating Pressure<sup>(1)</sup></b> 200 psig / 13.8 bar	<b>Inlet Check Valve:</b> 304 Stainless steel <b>Exhaust and Motive Supply:</b> 440 Stainless steel <b>Pump, Trap Outlet, Float and Lever:</b> Stainless steel
<b>Maximum Allowable Temperature<sup>(1)</sup></b> 572°F / 300°C	
<b>Maximum Operating Temperature<sup>(1)</sup></b> 388°F / 198°C	

1. The pressure/temperature limits in this Bulletin and any applicable standard or code limitation should not be exceeded.

## Principle of Operation

The pump operates on a positive displacement principle. Condensate enters the body through the inlet check valve causing the float to rise. The float is connected to the trap mechanism via a pivot. If the upstream system pressure is sufficient to overcome the backpressure, the build up of condensate will be discharged through the opening two stage trap mechanism. In this way, the float will modulate according to the rate of condensate entering the unit, controlling the rate of opening and closure of the trap. The snap action mechanism ensures a rapid change from the trapping mode to the active pumping mode. With the motive inlet valve open the pressure increases above the total backpressure and the condensate is forced out through the trap seat into the plant's return system.

## Installation

1. Ensure that the inlet pipe is sufficiently sized to accumulate condensate during the pump's discharge cycle in order to prevent condensate from backing up into the equipment being drained.
2. Generally, a length and diameter of a pipe is sufficient to accommodate the condensate capacity of 1.1 gal / 4.2 L
3. Ensure that the condensate reservoir is situated at least 1 pipe diameter below the process outlet but as high as possible above the inlet up to 40 in. / 1016 mm and installation head of minimum 8 in. / 203 mm from the base of the unit.
4. Install a throttling isolation valve to reduce the filling pressure. There are four connection ports; inlet (1-1/2 in. / DN 40), outlet (1 in. / DN 25), motive supply (1/2 in. / DN 15) and exhaust (1/2 in. / DN 15).

# Condensate Recovery Pump Trap

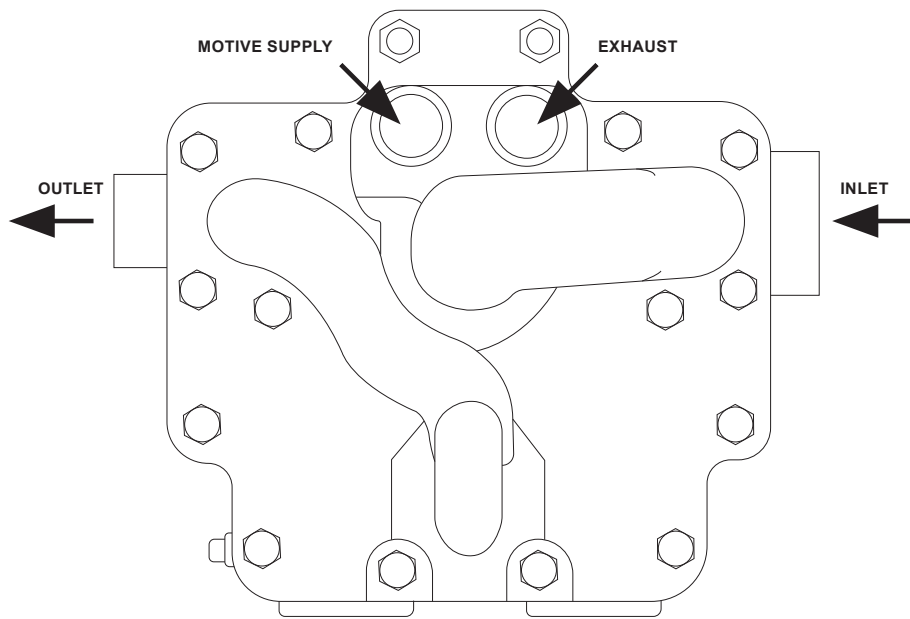

**Figure 2.** Operational Schematic

5. Connect the inlet port to the outlet of the equipment being drained.
6. Connect the outlet port to the condensate return line and size it correctly to prevent excessive backpressure on the unit. Flow arrows indicates the correct direction of flow.
7. Connect the 1/2 in. / DN 15 port marked S to a trapped motive steam supply.
8. The 1/2 in. / DN 15 port marked E should be balanced back as close as possible to the condensate outlet of the equipment.
9. Ensure that the system pressure gauges are fitted to the motive supply, condensate inlet and outlet.
10. Ensure that the motive pressure does not exceed 40 to 60 psi / 2.8 to 4.1 bar above the backpressure applied to the pump and must be drained by a suitable steam trap to ensure the motive steam is dry.

# Condensate Recovery Pump Trap

**Table 1. Condensate Recovery Pump Trap Capacity Table in lbs/hr**

PUMP TRAP		30 PSIG MOTIVE STEAM PRESSURE				100 PSIG MOTIVE STEAM PRESSURE						200 PSIG MOTIVE STEAM PRESSURE					
		0 psig backpressure		30 psig backpressure		0 psig backpressure		30 psig backpressure		72 psig backpressure		0 psig backpressure		30 psig backpressure		72 psig backpressure	
System Pressure, psig	Installation Head, In.	Pump	Trap	Pump	Trap	Pump	Trap	Pump	Trap	Pump	Trap	Pump	Trap	Pump	Trap	Pump	Trap
0	8	1026				850		620		513		850		487		423	
	12	1445				1196		958		773		992		780		678	
	16	1598				1366		1097		877		1119		908		790	
	20	1692				1478		1189		944		1220		994		865	
	30	1835				1657		1337		1050		1406		1136		990	
30	39	1915				1763		1425		1112		1553		1223		1066	
	8		1695		850		1695	1160		941		1695		941		815	
	12		3932		992		3932	1795		1408		3932		1534		1332	
	16		4966		1107		4966	2050		1587		4966		1695		1557	
	20		4975		1205		4975	2215		1700		4975		1792		1707	
	30		4998		1408		4998	2475		1875		4998		2248		1955	
75	39		5018		1553		5018	2626		1974		5018		2419		2104	
	8		1695		1695		1695		1695		1695		1695		1695		1695
	12		3932		3932		3932		3932		2165		3932		3932		2165
	16		5296		5296		5296		5296		2200		5296		5296		2272
	20		6374		5786		6374		5786		2345		6374		5786		2490
	30		7022		5804		7022		5804		2569		7022		5804		2844
150	39		7034		5820		7034		5820		2694		7034		5820		3075
	8		1695		1695		1695		1695		1695		1695		1695		1695
	12		3932		3932		3932		3932		3932		3932		3932		3932
	16		5296		5296		5296		5296		5296		5296		5296		5296
	20		6375		6375		6375		6375		6375		6375		6375		6375
200	30		8491		8378		8491		8378		7126		8491		8378		7126
	39		9120		8386		9120		8386		7135		9120		8386		7135
	8		1695		1695		1695		1695		1695		1695		1695		1695
	12		3932		3932		3932		3932		3932		3932		3932		3932
	16		5296		5296		5296		5296		5296		5296		5296		5296
200	20		6375		6374		6375		6374		6374		6375		6374		6374
	30		8491		8491		8491		8491		8491		8491		8491		8491
	39		10,021		9561		10,021		9561		8592		10,021		9561		8592
	39																

— Shaded areas indicate that capacity are not available.

# Condensate Recovery Pump Trap

**Table 2. Condensate Recovery Pump Trap Capacity Table in kg/hr**

PUMP TRAP		2.1 BAR MOTIVE STEAM PRESSURE				6.9 BAR MOTIVE STEAM PRESSURE						13.8 BAR MOTIVE STEAM PRESSURE					
		0 bar backpressure		2.1 bar backpressure		0 bar backpressure		2.1 bar backpressure		5 bar backpressure		0 bar backpressure		2.1 bar backpressure		5 bar backpressure	
System Pressure, bar	Installation Head, mm.	Pump	Trap	Pump	Trap	Pump	Trap	Pump	Trap	Pump	Trap	Pump	Trap	Pump	Trap	Pump	Trap
0	203	465				386		281		233		386		221		192	
	305	655				542		435		351		450		354		308	
	406	725				620		498		398		508		412		358	
	508	767				670		539		428		553		451		392	
	762	832				752		606		476		638		515		449	
	991	869				800		646		504		704		555		484	
2.1	203		769		386		769	526		427		769	427		370		
	305		1784		450		1784	814		639		1784	696		604		
	406		2253		502		2253	930		720		2253	769		706		
	508		2257		547		2257	1005		771		2257	813		774		
	762		2267		639		2267	1123		850		2267	1020		887		
	991		2276		704		2276	1191		895		2276	1097		954		
5.2	203		769		769		769		769		769		769		769		769
	305		1784		1784		1784		1784		982		1784		1784		982
	406		2402		2402		2402		2402		998		2402		2402	1031	
	508		2891		2624		2891	2624	1064				2891	2624	1129		
	762		3185		2633		3185	2633	1165				3185	2633	1290		
	991		3191		2640		3191	2640	1222				3191	2640	1395		
10.3	203		769		769		769		769		769		769		769		769
	305		1784		1784		1784		1784		1784		1784		1784		1784
	406		2402		2402		2402		2402		2402		2402		2402		2402
	508		2892		2892		2892		2892		2892		2892		2892		2892
	762		3851		3800		3851	3800		3232		3851	3800		3232		
	991		4137		3804		4137	3804		3236		4137	3804		3236		
13.8	203		769		769		769		769		769		769		769		769
	305		1784		1784		1784		1784		1784		1784		1784		1784
	406		2402		2402		2402		2402		2402		2402		2402		2402
	508		2892		2891		2892		2891		2891		2892		2891		2891
	762		3851		3851		3851		3851		3851		3851		3851		3851
	991		4545		4337		4545		4337		3897		4545		4337		3897

— Shaded areas indicate that capacity are not available.

# Condensate Recovery Pump Trap

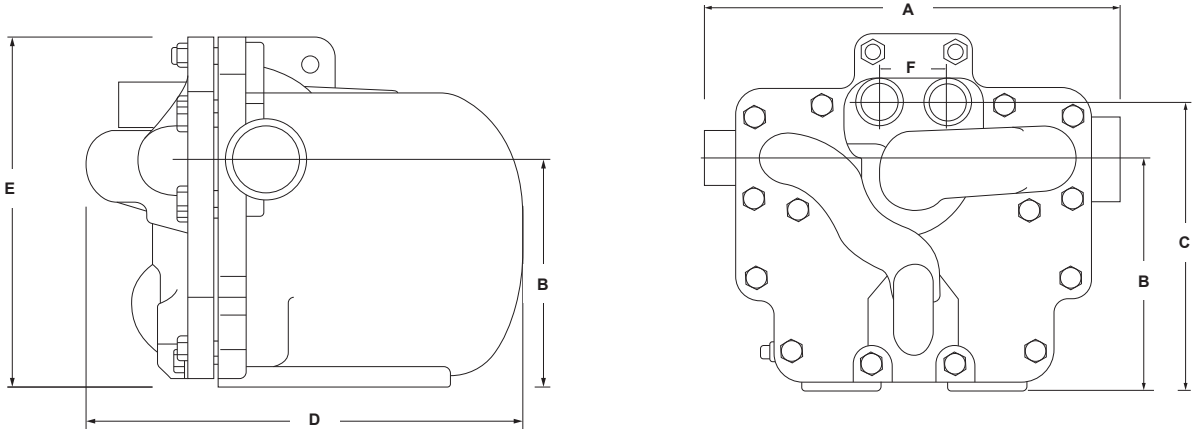

**Figure 3.** Condensate Recovery Pump Trap Dimensions

**Table 3.** Condensate Recovery Pump Trap Dimensions

DIMENSION	A	B	C	D	E	F
In. / mm	13.8 / 350	7.8 / 198	9.7 / 246	15.2 / 385	12.2 / 310	2.2 / 57

## Ordering Information

When ordering, complete the ordering guide on this page. Refer to the Specifications section. Review the description to the right of each specification and the information in each referenced table or figure. Specify your choice whenever a selection is offered.

## Ordering Guide

### End Connection (Select One)

- NPT
- BSPT

### Motive Pressure (Select One)

- 30 psig / 2.1 bar
- 100 psig / 6.9 bar
- 200 psig / 13.8 bar

### System Pressure (Select One)

- 0 psig / 0 bar
- 30 psig / 2.1 bar
- 75 psig / 5.2 bar
- 150 psig / 10.3 bar
- 200 psig / 13.8 bar

### Installation Head (Select One)

- 8 in. / 203 mm
- 12 in. / 305 mm
- 16 in. / 406 mm
- 20 in. / 508 mm
- 30 in. / 762 mm
- 39 in. / 991 mm

### Backpressure (Select One)

- 0 psig / 0 bar
- 30 psig / 2.1 bar
- 72 psig / 5.0 bar (100 and 200 psig / 6.9 and 13.8 bar only)

# Condensate Recovery Pump Trap

Regulators Quick Order Guide	
***	Readily Available for Shipment
**	Allow Additional Time for Shipment
*	Special Order, Constructed from Non-Stocked Parts. Consult your local Sales Office for Availability.
Availability of the product being ordered is determined by the component with the longest shipping time for the requested construction.	

**Specification Worksheet**

**Application:**  
 Specific Use \_\_\_\_\_  
 Line Size \_\_\_\_\_  
 Fluid Type \_\_\_\_\_  
 Specific Gravity \_\_\_\_\_  
 Temperature \_\_\_\_\_  
 Does the Application Require Overpressure Protection?  
 Yes     No

**Pressure:**  
 Maximum Inlet Pressure ( $P_{1max}$ ) \_\_\_\_\_  
 Minimum Inlet Pressure ( $P_{1min}$ ) \_\_\_\_\_  
 Downstream Pressure Setting(s) ( $P_2$ ) \_\_\_\_\_  
 Set Pressure \_\_\_\_\_  
 Maximum Flow ( $Q_{max}$ ) \_\_\_\_\_

**Accuracy Requirements:**  
 Less Than or Equal To:  
 5%     10%     20%     40%

**Construction Material Requirements (if known):**  
 \_\_\_\_\_  
 \_\_\_\_\_

 [SpenceValve.com](http://SpenceValve.com)

**Emerson**

**Americas**

McKinney, Texas 75069 USA  
 T +1 800 558 5853  
 +1 972 548 3574

**Europe**

Bologna 40013, Italy  
 T +39 051 419 0611

**Asia Pacific**

Singapore 128461, Singapore  
 T +65 6777 8211

**Middle East and Africa**

Dubai, United Arab Emirates  
 T +971 4 811 8100

FCBL-20126-EN © 2024,2026 Emerson Electric Co. All rights reserved 02/26.  
 Spence is a mark owned by a subsidiary of Emerson Electric Co. The Emerson logo is a trademark and service mark of Emerson Electric Co. All other marks are property of their respective owners

Neither Emerson nor any of its affiliated entities assume responsibility for the selection, use or maintenance of any product. Responsibility for proper selection, use, and maintenance of any product remains solely with the purchaser and end user.

The contents of this publication are presented for informational purposes only, and while every effort has been made to ensure their accuracy, they are not to be construed as warranties or guarantees, express or implied, regarding the products or services described herein or their use or applicability. All sales are governed by our terms and conditions, which are available upon request. We reserve the right to modify or improve the designs or specifications of such products at any time without notice.

