

Spence™

Designer's Guide

Edition VI



Steam and Fluid Control

Regulators | Pilots and Combinations | Control Valves | Direct Operated Valves |
Noise Suppression Insulation | Desuperheaters | Piping Specialties



The contents of this publication are presented for informational purposes only, and while every effort has been made to ensure their accuracy, they are not to be construed as warranties or guarantees, express or implied, regarding the products or services described herein or their use or applicability. All sales are governed by our terms and conditions, which are available upon request. We reserve the right to modify or improve the designs or specifications of such products at any time without notice.

Emerson Process Management Regulator Technologies, Inc does not assume responsibility for the selection, use or maintenance of any product. Responsibility for proper selection, use and maintenance of any Emerson Process Management Regulator Technologies, Inc. product remains solely with the purchaser.

SPENCE™ ENGINEERING COMPANY, INC

The Spence Engineering Company was established in 1926 by Paulsen Spence in Walden, New York. Paulsen Spence developed the original patent for the normally closed external pilot operated packless pressure regulator. This design is the basis for the products offered today. This technology offers the maximum in application and selection flexibility, with regulators up to 12 inches in cast iron and cast steel. These pilots are used to control pressure, temperature, differential pressure or back pressure either mechanically or with a pneumatic pilot.

As a widely recognized leader in steam regulator and flow control, Spence regulators are used extensively for heating systems in buildings, institutions and district heating system as well as major industrial plant.

In 1984, Spence Engineering was acquired by Watts Industries. The company continued to grow and develop new fluid control and steam specialty products. A new line of pneumatic control valves was introduced in 1986. In 1989, a range of self contained temperature regulators was added to the line to meet the demand for an economical temperature regulator.

In the active year of 1990, Spence became certified by ASME for the assembly and setting of safety relief valves, manufactured by sister company Watts company in Canada.

Product development continued with the introduction of free float steam traps and pressure operated condensate pumps. In 1996, Watts moved the safety valves manufacturing to the Walden, New York plant which became an ASME certified manufacturer of bronze and iron safety relief valves.

In 2019, Spence and Nicholson were acquired by Emerson from CIRCOR International.

Emerson continues to focus attention on offering Spence steam specialty solutions for the regulation and control of steam and fluids and being the single source supplier to the institutional marketplace.

For more information on Spence products, visit our website at www.SpenceValve.com.

TABLE OF CONTENTS

INTRODUCTION TO REGULATORS

- OPERATIONS OF A REGULATOR
 - HOW TO CHOOSE A REGULATOR
 - QUICK SELECTION GUIDES
- PAGE 14 - 20

MAIN VALVES

- STANDARD
 - LOW PRESSURE - LOW DIFFERENTIAL
 - HIGH PRESSURE - LOW DIFFERENTIAL
- PAGE 22 - 34

PILOTS

- PRESSURE REDUCING
 - AIR ADJUSTED
 - DIFFERENTIAL PRESSURE
 - BACK PRESSURE
 - TRIP STOP
 - PRESSURE SAFETY
 - SOLENOID
 - ELECTRONIC ACTUATOR
 - TEMPERATURE
 - PRESSURE AND TEMPERATURE
 - PNEUMATIC TEMPERATURE CONTROLLER
- PAGE 36 - 60

COMBINATION REGULATORS

- PRESSURE REDUCING
 - INTEGRAL MOUNT PRESSURE REDUCING
 - TEMPERATURE REGULATOR
 - AIR OPERATED
- PAGE 62 - 70

DIRECT OPERATED VALVES

- TEMPERATURE REGULATOR
 - PRESSURE REDUCING
 - DIFFERENTIAL PRESSURE
 - WATER PRESSURE REDUCING
- PAGE 72 - 84

REGULATOR SIZING

- CAPACITY TABLES
 - SIZING AND SELECTION
 - FLOW COEFFICIENTS
- PAGE 86 - 113

CONTROL VALVES

- PNEUMATIC CONTROL VALVES
 - ELECTRIC CONTROL VALVES
 - ACTUATORS
 - ELECTRO-PNEUMATIC TRANSDUCER
 - THERMOMETER
 - ELECTRIC PRESSURE TRANSMITTER
 - POSITIONERS
- PAGE 115 - 141

CONTROL VALVE SIZING

- FORMULAS
 - CONVERSIONS
 - SPECIFICATION FORM
- PAGE 143 - 145

SEPARATORS, DESUPERHEATERS AND NOISE REDUCTION

- STEAM AND AIR SEPARATORS
 - DESUPERHEATERS
 - NOISE SUPPRESSORS
 - MUFFLING ORIFICE PLATES
- PAGE 147 - 172

APPLICATION GUIDE

- RECOMMENDED INSTALLATIONS
- PAGE 173 - 209

REFERENCE AND PIPING DESIGN

- GLOSSARY OF TERMS
 - VELOCITY CHART
 - FLANGE STANDARDS
 - CONVERSION TABLES
 - PIPE TABLES
- PAGE 210 - 233

TABLE OF CONTENTS

READY TO START?

The best way to make a selection is to contact your local Spence Technical Sales Representative. Our network of technically trained Spence Representatives can direct you to local inventory of Spence products for fast service. They can also help you in the selection and sizing of regulators, pilots, desuperheaters and noise suppression products. To contact your local Spence Representative, visit www.spencevalve.com.

SECTION I

INTRODUCTION TO REGULATORS

How to Choose a Regulator	14
The Operation Cycle of a Spence Pressure Regulator	15
The Operating Cycle of a Spence Temperature Regulator	16
Quick Selection Chart for Steam Pressure Regulators	17
Quick Selection Chart for Temperature Regulators	18
Spence Main Valve Specification Table	19

MAIN VALVES

Type E Main Valve	22
Type E2 Main Valve	24
Type E5 Main Valve	26

MAIN VALVE ACCESSORIES

Main Valve Options	30
Insulcap Jacket	32
Auxiliary Fittings	33

PILOTS

Type D Pressure Reducing Pilot	36
Type A Air Adjusted Pilot	38
Type N Differential Pressure Pilot	40
Type Q Back Pressure Pilot	42
Type P125 Trip Stop Pilot	44
Type SP/P Pressure Safety Pilot	46
Type M Solenoid Pilot	48
Type VH210	50
Type T124/134 Temperature/Pressure Pilot	52
Type T14 Vapor Tension Temperature Pilot	54
Type T61 Pneumatic Temperature Controller	56
Material Specifications for Main Valves and Pilots	57

PILOT ACCESSORIES

Thermostat Bulbs and Wells	60
----------------------------	----

COMBINATION REGULATORS

ED Series Pressure Regulator Features	62
Type ED Series Pressure Regulator	63
Type E2D Series Pressure Regulator	64
Type ED and ED2 Integral Mound Pressure Regulator	65
Type EA Series Pressure Regulator	66
Type ET14 Temperature Regulator	67
Type ET14D Pressure Limiting Temperature Regulator	68
Type ET124/ET134 and E2T134 Temperature and Pressure Regulator	69

DIRECT OPERATED VALVES

Series 2000 Temperature Regulator Features	72
Type D50A Pressure Reducing Valve	75
Type N6 Differential Pressure Valve	78
Type D and D2 Differential Pressure Valve	80
Type D34 Water Pressure Reducing Valve	82

REGULATOR SIZING

Definitions Relating to Regulator Capacity	86
Planning Main Valve Installation	87
Main Valve Selection	88
Valve Sizing By Computation	89
Pressure Reducing Station Design Guidelines	90
Pressure Reducing Station General Specification	90
Regulator Cv Data	91
Saturated Steam Flow Table (lb/hr)	92
Selecting Pressure Pilots	94
Sizing Pressure Regulators	95
Sizing Series 2000 Temperature Regulator	96
Series 2000 Temperature Regulator	97
Rated Steam Capacity Table	99
Selecting Temperature Pilots	100

Sizing Temperature Regulators	101
Selecting Differential Pressure Pilots	102
Sizing Differential Pressure Regulators	103
Selecting Back Pressure Pilots	104
Sizing Back Pressure Regulators	104
Selecting Pump Governor Pilots	105
Rated Steam Capacity Table	106
D50A Rated Steam, Air and Water Capacity Table	113

SECTION II

CONTROL VALVES

Series K Control Valve	115
Capacity Tables	119
Type J Control Valve Features	123
Type J Control Valve	124
Shutoff and Cv Tables	126
Capacity Tables	127

CONTROL VALVE OPTIONS AND ACCESSORIES

Packing Configurations	135
Actuators	136
Electro – Pneumatic (I/P) Transducer	136
RTD Resistance Probe Thermometer	137
Electronic Pressure Transmitter	137
Eckardt Positioner	138
PMV Positioner	139
Moore Positioner	140

CONTROL VALVE SIZING

Valve Sizing By Computation	143
Piping Geometry Factors	144

SECTION III

STEAM AND AIR SEPARATOR

Eliminator Series Steam and Air Separator	147
Sizing Eliminator Steam Separator	149

DESUPERHEATERS

Desuperheaters	153
Rules for Sizing Desuperheaters	155

NOISE REDUCTION

Noise Suppressor	157
Muffling Orifice Plates (MOPS)	160
Throttling Orifice Plates (TOPS)	161
Noise Reduction Design Guidelines	163

SECTION IV

APPLICATION GUIDE

Type ED Single Stage Pressure Reducing Valve	173
Type ED Parallel (Additive) Pressure Reducing Station	174
Type ED Two-stage Pressure Reducing Station	175
Type ED Turbine Exhaust make-up Valve	176
Type ED Remote Shut off	177
Type ED Remote Mounted Pilot	178
Type EP125 Trip Valve	179
Type D50A Direct Operated Pressure Reducing Valve	180
Type ED5 Pressure Regulator for Accurate Control of a Deaerator	181
Type E2 Slow Opening Valve	182
Type ET14 and ET14D Temperature Regulator	183

Type ET124 and ET134 Temperature Regulator	184
Type ET14D Temperature Regulator	185
Type ET14T14 Temperature Regulator	186
Type ET134 Temperature Regulator for Poultry Scalding	187
Series 2000 Direct Operated Temperature Regulator for Storage Heater	188
Series 2000 Direct Operated Temperature Regulator for Plate Heater	189
Series 2000 Direct Operated Temperature Regulator for Engine Jacket Cooling	190
Series 2000 Direct Operated Temperature Regulator for Liquid Cooling Tank	191
Series 2000 Direct Operated Temperature Regulator for three-way Blending/Mixing	192
Series 2000 Direct Operated Temperature Regulator for Three-way Diverting	193
Type EAT61 Air Controlled Temperature Regulator	194
Type EA Temperature Regulator for Remote Thermostat Control	195
Type ET134 Self-contained Temperature Regulator for Starch Mixer	196
Type ET124A Viscosity/Temperature Regulator	197
Type EQ Back Pressure Regulator	198
Type EQ Back Pressure Valve with Flow Control Orifice	199
Type EN33 Differential Regulator	200
Type N6 Differential Pressure Valve	201
Steam Atomizing Air Operated Desuperheater	202
Mechanical Atomizing Air Operated Desuperheater	203
Pressure Regulator with Muffling Orifice	204
Pressure Regulator with Noise Suppressor	205
Type J Control Valve and Liquid Level Controller for Boilers	206
Type J Control Valve with Electro-pneumatic positioner for computerized Cogeneration Control	207
Type J Control Valve for Level/Make-up on a Deaerator	208

SECTION V

REFERENCE AND PIPING DESIGN

Glossary of Terms	211
Flow vs. Velocity Chart	212
Reference Tables	213
Pressure Temperature Limits	220
Spence Typical Installation for Sanitary Steam System	221
Spence Single Stage Pressure Reducing Station	222
Spence Two Stage Pressure Reducing Station	223
Spence Single Stage Parallel Pressure Reducing Station	224
Spence Two Stage Parallel Pressure Reducing Station	225
Spence Typical Installation for Instantaneous Heater	226
Spence Typical Installation for Storage Heater	227
Steam Tables	229

It is solely the responsibility of the system designer and the user to select products suitable for their specific application requirements and to ensure proper installation, operation, and maintenance of these products. Assistance shall be afforded with the selection of the materials based on the technical information supplied to Spence Engineering Company, Inc. Applicable codes, material compatibility, Product ratings and application details should be considered in the selection and application. Improper selection, application or use of the products described herein can cause personal injury or property damage. If the product is intended for an application or use other than originally specified, the system designer and or user must reconfirm that the selection is suitable for the new operation conditions.

SECTION I REGULATORS

HOW TO CHOOSE A REGULATOR

If you already know the product that you want information on, find the product page in the Table of contents. Pages showing popular combinations of Pilot and Regulators are found in the Combination Regulators Chapter. Detailed product information on materials, ratings, dimensions, weights and applications are found in the Products Chapters. All sizing information is contained in the Regulator Sizing Chapter. If you are not sure of what you need, collect all the following information. You will need it to select the right product for your needs.

Inlet Pressure

Flow Rate

Flow Media (i.e.: Steam, water. etc.)

Desired Delivery Pressure

Noise Restrictions, if any

Type of Pilot Control (i.e.: Self Contained, Pneumatic, Electronic, etc.)

Application (i.e.: Temperature Regulation, Single stage Pressure Regulation, etc.)

Application data is listed on each Product Page. If you identify the nature of the installation, it will assist you selecting the proper equipment.

DIRECT ACTING OR PILOT OPERATED REGULATOR?

You may be able to use a Direct Operated Regulator for your application. They are generally less expensive than Pilot Operated Regulators. However, they do not provide the same level of accuracy or rangeability. If a Direct Acting Regulator is an option, consult the Direct Operated Valves Chapter to determine which best fits your specific needs. Then, consult the appropriate pages in the Regulator Sizing Chapter to select the exact size you need.

If a Pilot Operated Regulator is required, go to Page 15 (for Pressure Regulators) or Page 16 (for Temperature Regulators). These selection charts will help you to quickly determine the type of product that you need. The Pilot can be self contained, pneumatically or electronically actuated. Consult the appropriate pages in the Regulator Sizing Chapter to select the exact size Regulator and Pilot you need. Overall dimensions of the most popular combinations are provided in the Combination Regulators Chapter.

ECONOMICAL, ENGINEERED OR ENGINEERED WITH NOISE SUPPRESSION?

The choice of how to size a regulator for and application is up to you. The most economical choice does not necessarily take into consideration the optimum loading of the Regulator, which could affect it's service life. Properly engineered Spence Regulators have been in continuous service for as much as 50 years. In high pressure reduction stations, noise can be a serious environmental problem. Spence offers a number of Noise Suppression products to reduce this problem. You will find comprehensive noise reduction sizing and selection information in the Noise Reduction Chapter.

THE OPERATING CYCLE OF A SPENCE PRESSURE REGULATOR

The basic Type ED has been selected to illustrate the operation of a SPENCE Pilot Operated Pressure Regulator. This presentation describes the successive steps in the mechanical cycle of the Regulator.

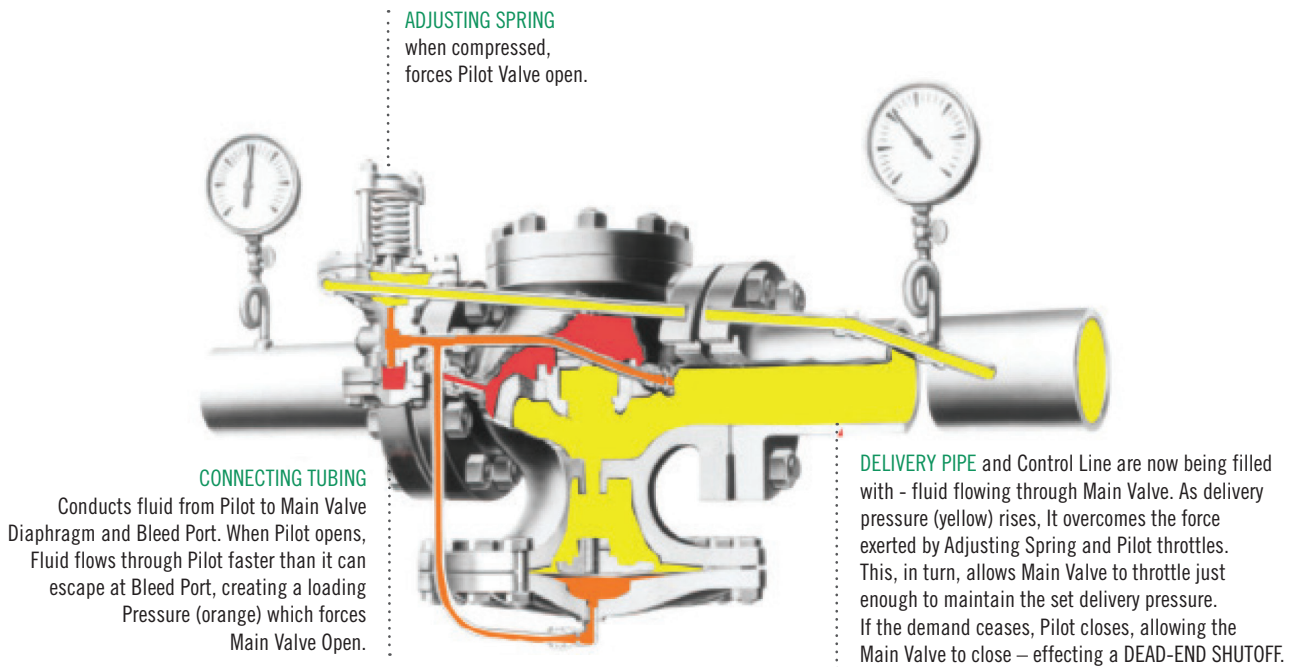
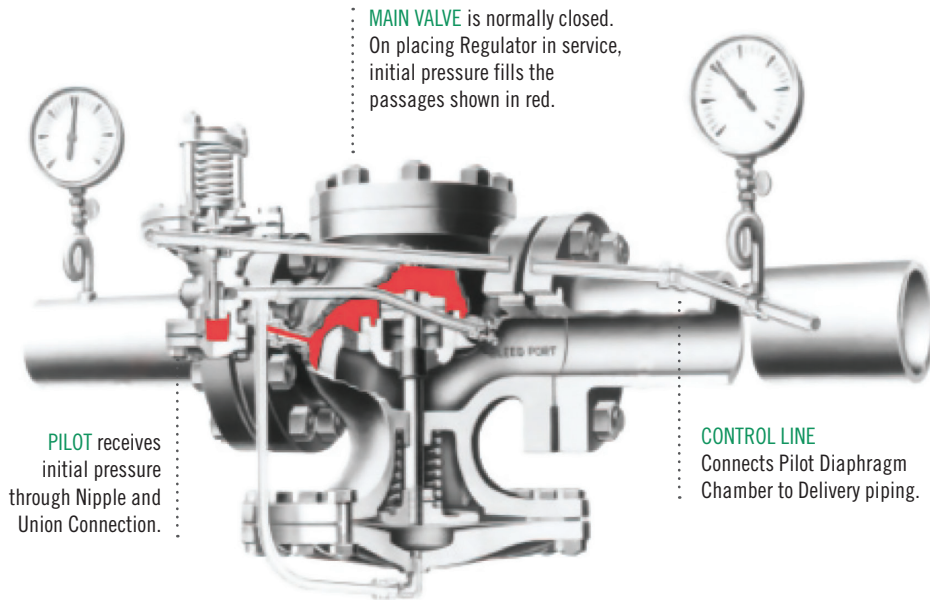

KEY ● HIGH PRESSURE ● MEDIUM PRESSURE ● LOW PRESSURE

THE OPERATING CYCLE OF A SPENCE TEMPERATURE REGULATOR

The Type ET134 has been selected to illustrate the operation of a SPENCE Pilot Operated Temperature Regulator. This presentation describes the successive steps in the mechanical cycle of the Regulator.

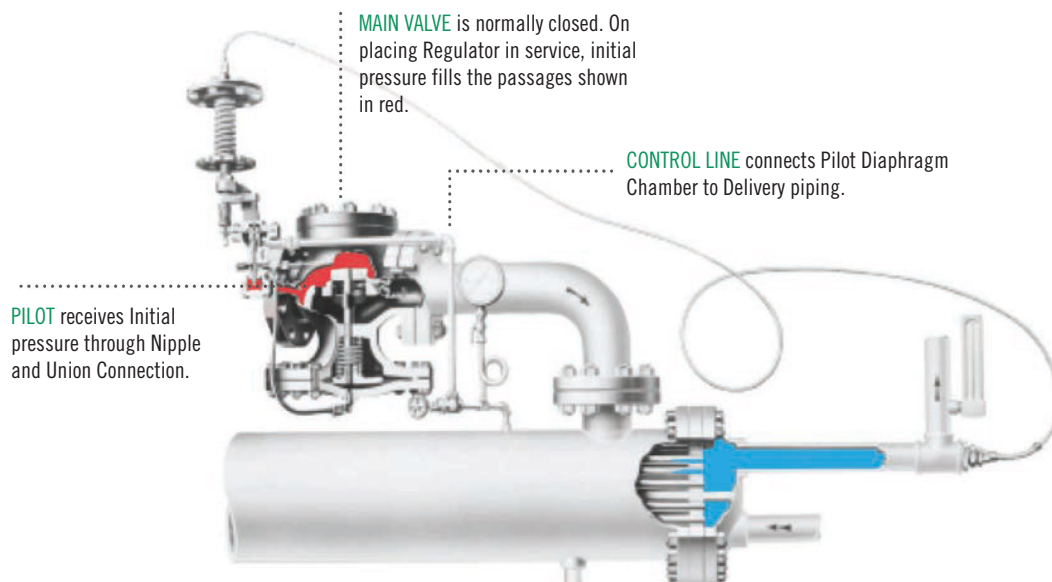

KEY ● INITIAL STEAM PRESSURE ● LOADING STEAM PRESSURE ● DELIVERY STEAM PRESSURE ● VAPOR PRESSURE ● FLUID HEATED

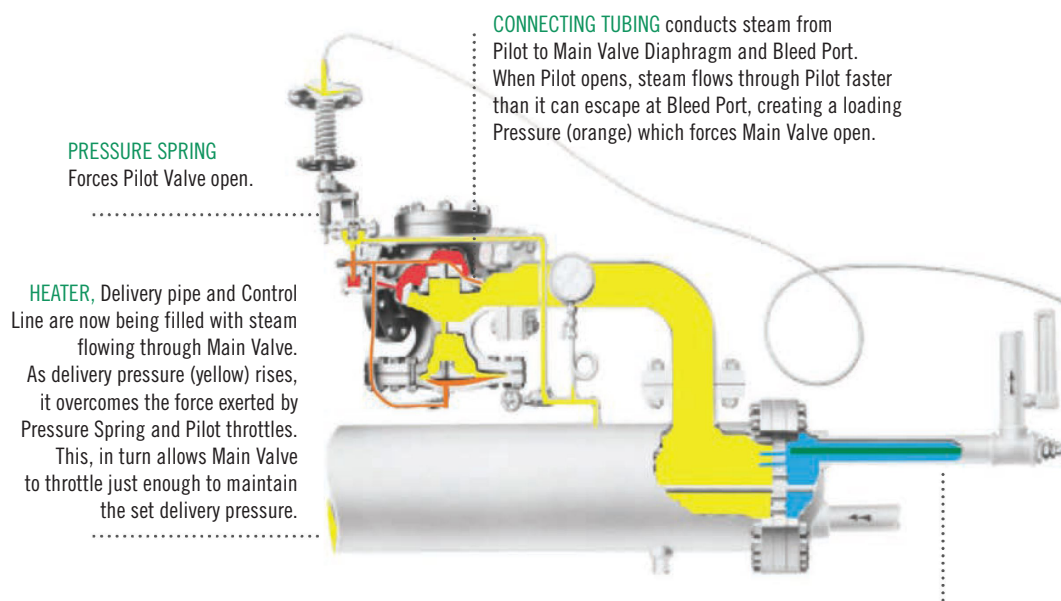

THERMOSTAT ELEMENT (vapor tension type) is connected into heater outlet. The rising temperature of the fluid (blue) being heated creates a Vapor pressure (green) on the Temperature Diaphragm. When this pressure has reached a point sufficient to overcome the Temperature Adjusting Spring, it Applies a force on the Lever so as gradually to decrease the spring loading on The Pressure Diaphragm. This produces a stem-by-step reduction in the Delivery pressure as the temperature rises through several degrees. If the desired temperature is exceeded, the vapor pressure on the Pilot Temperature Diaphragm overcomes the forces of the Spring. This allows Pilot and Main Valve to close tight.

QUICK SELECTION CHART FOR STEAM PRESSURE REGULATORS

Review the application data that you have collected. Consult the chart, starting with the inlet pressure that matches the inlet pressure you have. Next, select your outlet pressure (reduced or delivery pressure). Then select the type of pilot control that you will be using and, finally, the level of accuracy that your system requires. This will lead you to a recommended regulator. Please bear in mind that these recommendation are general in nature and you should check the Product Pages and Sizing Section to ensure you have selected the correct product. If you need assistance, contact your local Spence Technical Sales Representative.

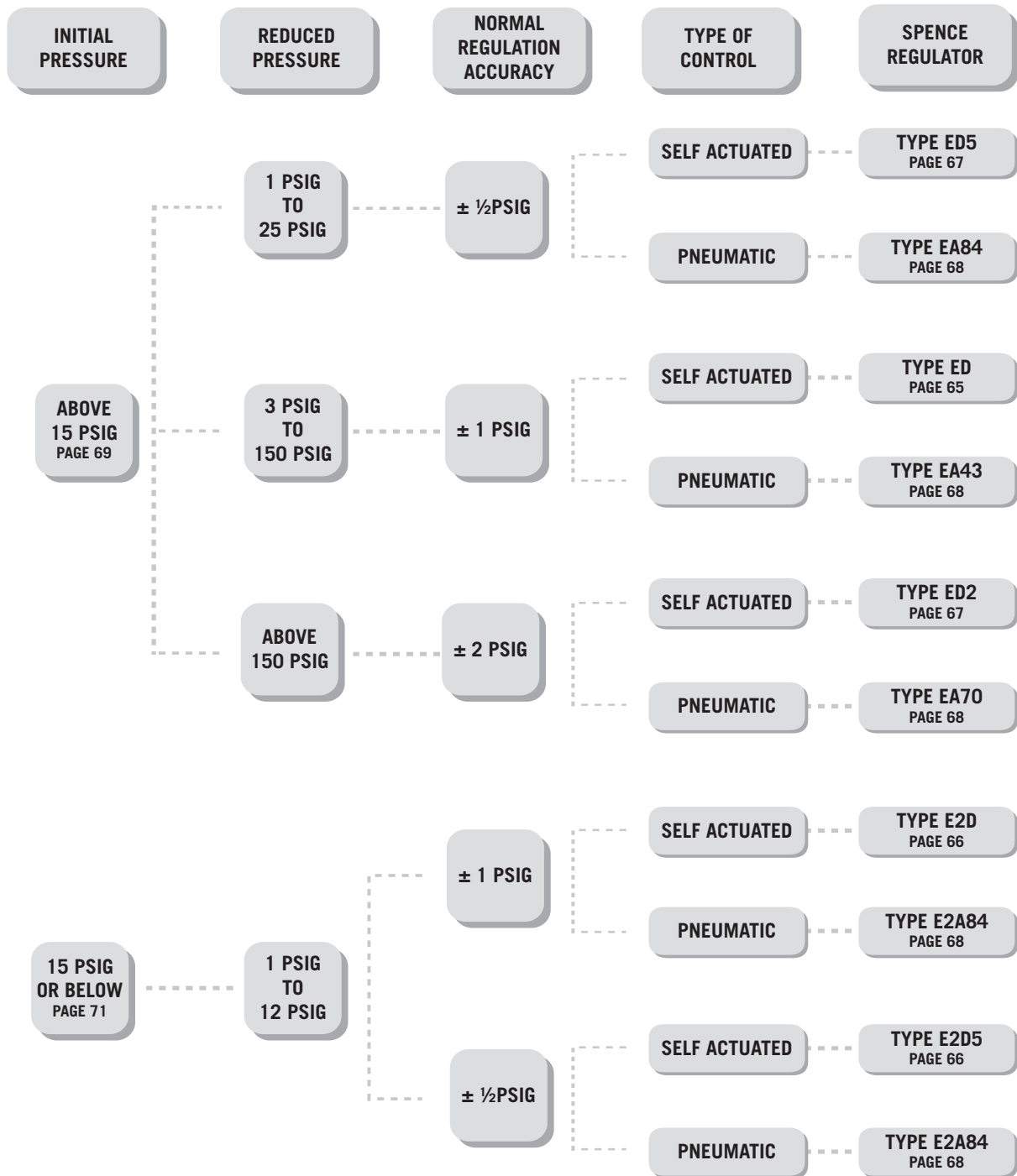

QUICK SELECTION CHART FOR TEMPERATURE REGULATORS

Review the application data that you have collected. Consult the chart, starting with the inlet pressure that matches the inlet pressure you have. Next, select your outlet pressure (reduced or delivery pressure). Then select the type of pilot control that you will be using and, finally, the level of accuracy that your system requires. This will lead you to a recommended regulator. Please bear in mind that these recommendations are general in nature and you should check the Product Pages and Sizing Section to ensure you have selected the correct product. If you need assistance, contact your local Spence Technical Sales Representative.

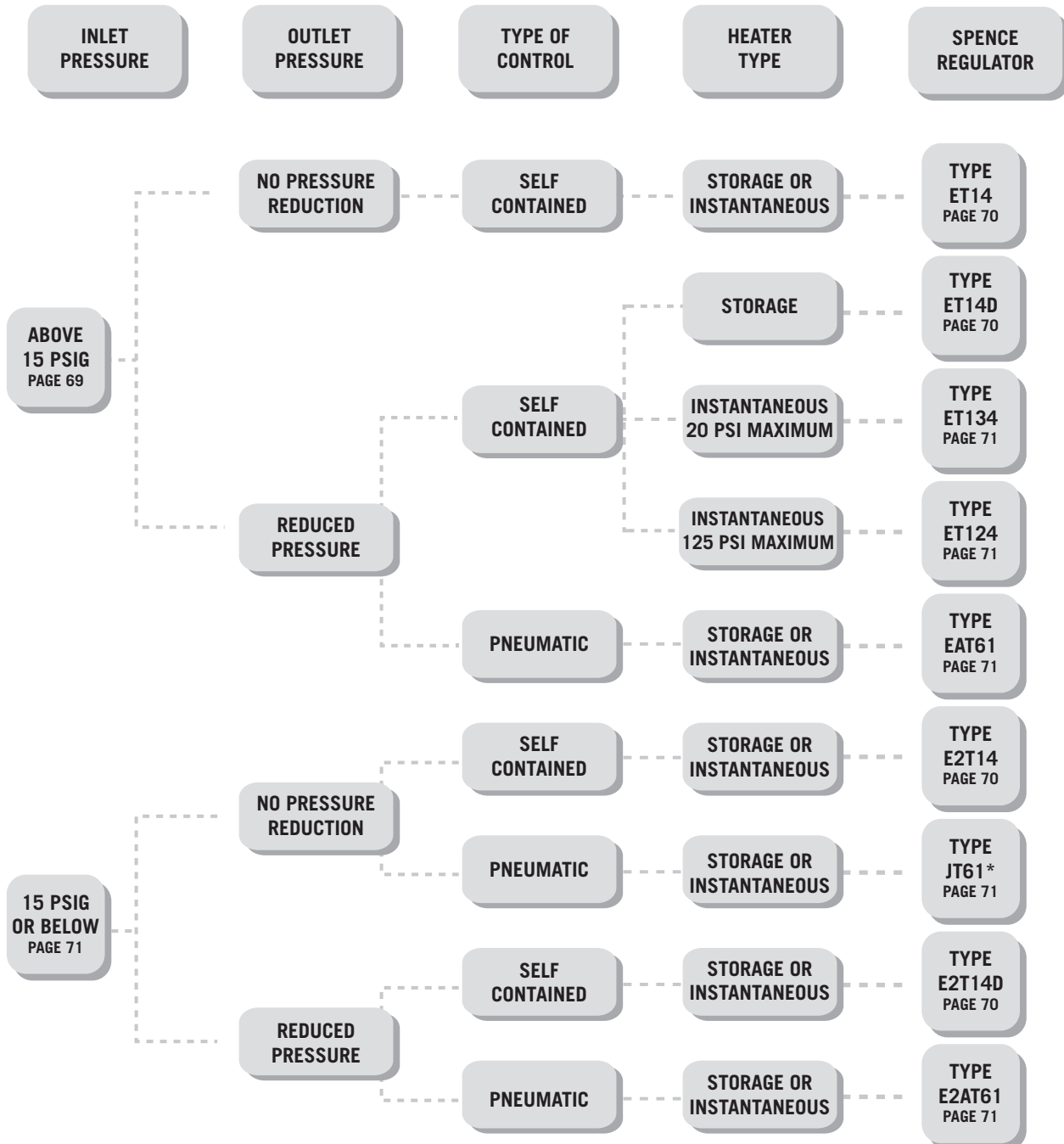

*See Control Valve Section, Page 116

SPENCE MAIN VALVE SPECIFICATION TABLE

TYPES		SIZES, BODY MATERIAL ^a AND FACINGS							OTHER MATERIAL						
		CAST IRON			CAST STEEL				Diaphragm	SEAT RINGS		DISCS		Stem	Main Spring
		Screwed Ends	Flanged ANSI 125	Flanged ANSI 250	Screwed Ends	Flanged ANSI 150	Flanged ANSI 300	Flanged ANSI 600		Steam Service	Water, Oil, Air or Gas Service	Steam Service	Water, Oil, Air or Gas Service		
E	SIZES - INCHES	3/8-2	1-12	1-12	3/4-2	1-12	1-12	1/2-8	Stainless Steel	316/420 ^d	316/420	304/420	Hycar	Stainless Steel or 17-4PH ^e	Carbon Steel, Stainless Steel or Inconel
	Max. Initial Pressure - psi	250	125	250	300	150	300	600							
	Max. Initial Temperature - F ^o	450	450	450	750	500	750	750							
	Min. Differential - psi ^h	10/30/50	10/30/50	10/30/50	10/30/50	10/30/50	10/30/50	10/30/50							
E2	SIZES - INCHES	3/4-2	1-12	—	—	—	—	—	Hycar	316	—	304/420	—	Stainless Steel	Carbon Steel
	Max. Initial Pressure - psi	15	15	—	—	—	—	—							
	Max. Initial Temperature - F ^o	250	250	—	—	—	—	—							
	Min. Differential - psi ^h	3	3	—	—	—	—	—							
E5	SIZES - INCHES	3/4-2	1-12	1-12	3/4-2	1-12	1-12	—	Hycar	316/420	316/420	304/420	304/420	Stainless Steel	Carbon Steel
	Max. Initial Pressure - psi	250	125	250	300	150	300	—							
	Max. Initial Temperature - F ^o	450	450	450	600	600	600	—							
	Min. Differential - psi ^h	5	5	5	5	5	5	—							

- A. Main Valves for corrosive fluids or costly gases require special materials.
- B. Bronze body and blind flange only.
- C. Minimum Differential is the smallest permissible difference between initial pressure (measured at the inlet) and the delivery pressure (measured at the outlet) of the main valve, to achieve full travel..
- D. Secoweld seat construction described in options section is regularly furnished for service pressures 400 psi and higher.
- E. 17-4 PH stems are furnished for service temperatures exceeding 600°F.
- F. Inconel springs are furnished for services pressure exceeding 400 psi and /or temperatures exceeding 600°F
- G. Standard spring (HP) requires minimum 30 PSI differential. 50 PSI is recommended minimum differential. Use optional Low ^P (LP) main spring for 15 psi minimum differential.10 psi minimum differential is attainable by adding base bypass, 1/16” bleed port and 5B open elbow.

INTRO TO REGS



NOTES:

A series of horizontal dotted lines for taking notes, spanning the width of the page below the 'NOTES:' header.

MAIN VALVES

TYPE E MAIN VALVE



TYPE E MAIN VALVE

SIZING INFO PAGE 93

VALVE RATINGS

Service	Trim Type	Maximum Cold Working Pressure	Maximum Inlet Pressure	Maximum Temperature
CAST IRON				
NPT or BSPT	Standard	250 psig (17.2 bar)	250 psig (17.2 bar)	406°F (207°C)
CL125 FF		125 psig (8.6 bar)	125 psig (8.6 bar)	450°F (232°C)
CL250 RF		250 psig (17.2 bar)	250 psig (17.2 bar)	450°F (232°C)
PN16 RF		125 psig (8.6 bar)	125 psig (8.6 bar)	446°F (230°C)
PN25 RF		250 psig (17.2 bar)	250 psig (17.2 bar)	446°F (230°C)
CAST STEEL				
NPT or BSPT	Standard	300 psig (21 bar)	300 psig (21 bar)	600°F (315°C)
CL150 RF or PN16 RF		150 psig (10.3 bar)	150 psig (10.3 bar)	500°F (260°C)
CL300 RF or PN25 RF		300 psig (21 bar)	300 psig (21 bar)	600°F (315°C)
CAST STEEL WITH SECOWELD SEAT				
NPT, BSPT, CL300 RF or PN25 RF	Standard	300 psig (21 bar)	300 psig (21 bar)	600°F (315°C)
PN25 RF		600 psig (41.4 bar)	600 psig (41.4 bar)	600°F (315°C)
CL600 RF		580 psig (40 bar)	529 psig (36.5 bar)	600°F (315°C)
PN40 RF				
NPT, BSPT or CL300 RF	High Temperature (up to 750F)	300 psig (21 bar)	300 psig (21 bar)	750°F (400°C)
CL600 RF		600 psig (41.4 bar)	600 psig (41.4 bar)	750°F (400°C)
PN25 RF		300 psig (21 bar)	294 psig (20.3 bar)	750°F (400°C)
PN40 RF		580 psig (40 bar)	469 psig (32.4 bar)	750°F (400°C)

750°F (400°C) construction available on request.

Other pressure/temperature ratings available; consult factory

Maximum downstream pressure is 300 psi.

Canadian Registration # OC19760

SIZE 3/8" - 12"

PRESSURES TO 600 PSIG AT 750°F

- Normally Closed
- Single Seat
- Balanced Metal Diaphragms
- Protected Main Spring
- Liquid, Gas and Vapor Applications
- Multiple Trims for Precise Sizing
- ANSI/FCI 70-3 Class VI Shutoff
- FCI 70-3 Class VI Shutoff
- Virtually Frictionless for long Service Life
- Packless Construction
- Easy In-line Maintenance
- Wide Variety of Pilots for Many Applications
- Minimum Differential Pressure 10psi (.7 bar)

APPLICATION DATA

- Pressure Regulating for Steam and Liquid Distribution
- Regulating for Process Control (Temperature or Pressure)
- Maintain Back Pressure or Differential Pressure
- For use with Self-contained, Pneumatic or Electronic Pilots
- Single Point or Multiple Use Applications
- Slow Start-up or Shutdown

OPTIONS (SEE PAGE 30)

- Composition Disc
- Balanced Construction
- Insulcap Insulating Jacket
- High Temperature Construction
- Low ΔP (LP) Main Spring
- Parabolic Disc
- Integral Mount Pilot
- Secoweld
- Dashpot
- EZ Connections

TYPICAL CONFIGURATIONS

PRESSURE REDUCING.....TYPE ED SERIES
 AIR ADJUSTED.....TYPE EA SERIES
 BACK PRESSURE.....TYPE EQ SERIES
 SOLENOID CONTROLLED.....TYPE EMD
 SOLENOID ACTUATED.....TYPE EM
 DIFFERENTIAL.....TYPE EN
 TEMPERATURE CONTROL.....TYPE ET SERIES

RATED FLOW COEFFICIENTS (Cv)

SEAT FACTOR	REGULATION SIZE														
	3/8	1/2	3/4	1	1-1/4	1-1/2	2	2-1/2	3	4	5	6	8	10	12
Full	1.5	2.8	5.4	8.8	14.1	19.8	31	44	74	109	169	248	444	706	1113
Full 75%	--	2.2	4.2	7.2	11.1	15.9	22.9	37	56	88	136	188	353	558	880
Full 50%	--	1.7	2.6	6.3	7.4	11.3	17.7	25	42	65	94	139	252	400	631
Normal	.66	1.55	4.8	7.5	10.4	14.6	17.6	24	43	78	115	151	249	377	631
Normal 75%	--	--	--	--	--	--	--	18	34	62	89	110	187	294	463
Normal 50%	--	--	--	--	--	--	--	14	26	46	65	83	139	230	363

TYPE E MAIN VALVE

SPECIFICATION

The valve shall be self-contained external pilot type, single seated, metal diaphragm actuated, normally closed design. The valve will function quickly and shut on dead end service. Internal parts including seats, discs, stems and diaphragms shall be of stainless steel. There shall be easy to maintain with all parts accessible without removal from the line.

MATERIALS OF CONSTRUCTION

Body, Cast IronASTM A126 CL B
 Body, Cast SteelASTM A216 WCB
 Stem303 St. Stl. ASTM A582
 Disc 3/4 - 5"420 St. Stl. ASTM A743 CA-40
 Disc 6 - 12"304 St. Stl. ASTM A167/A240
 Seat 3/4 - 5"420 St. Stl. ASTM A743 CA-40
 Seat 6 - 12"316 St. Stl. ASTM A743 CF-8M
 GasketGraphite
 DiaphragmStainless Steel. MIL-S-5059C
 SpringSteel

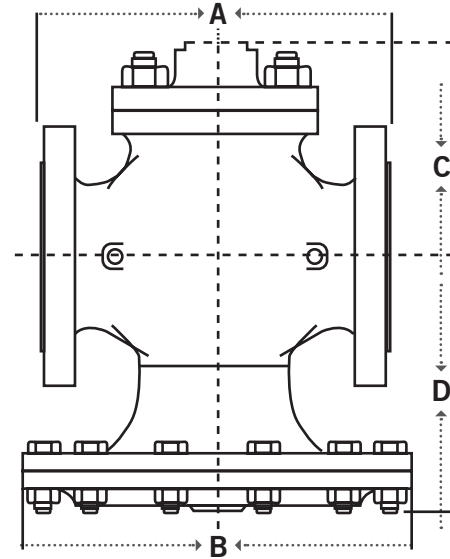

TYPE E MAIN VALVE

FITTINGS ON PAGE 34

MAIN VALVES

DIMENSIONS, in. (mm) AND WEIGHTS, lbs (kg)

SIZE	FACE TO FACE DIMENSIONS					B	C					D*	APPROX. WT.			
	A						Std. Mount	Integral Mount			ANSI NPT		ANSI 125,150	ANSI 250,300	ANSI 600	
	ANSI NPT	ANSI 125,150	ANSI 250	ANSI 300	ANSI 600			All Except CL600	ANSI 600	CI All						Steel
3/8 (10)	4-3/8 (111)	--	--	--	--	5-7/8 (149)	2-3/4 (70)	--	3-1/2 (89)	3-1/2 (89)	--	5-1/4 (133)	14 (6)	--	--	--
1/2 (12)	4-3/8 (111)	--	--	--	6 (152)	5-7/8 (149)	2-3/4 (70)	2-3/4 (70)	33-1/2 (89)	3-1/2 (89)	3-5/8 (92)	5-1/4 (133)	14 (6)	--	--	20 (9.1)
3/4 (19)	4-3/4 (121)	--	--	--	6-3/8 (162)	6-1/2 (162)	2-7/8 (73)	3-7/8 (98)	3-5/8 (92)	3-5/8 (92)	4-1/2 (114)	5-1/2 (140)	18 (8)	--	--	28 (13)
1 (25)	5-3/8 (137)	5-1/2 (140)	6 (152)	6-1/2 (165)	6-1/2 (165)	7 (178)	3-5/8 (92)	4-1/4 (108)	4-3/8 (111)	4-3/8 (111)	4-3/4 (121)	6-1/4 (159)	23 (10)	26 (12)	31 (14)	32 (15)
1-1/4 (32)	6-1/2 (165)	6-3/4 (171)	7-1/4 (184)	7-7/8 (200)	7-7/8 (200)	7-7/8 (200)	4-1/8 (105)	4-5/8 (117)	4 (102)	4-5/8 (117)	5 (127)	6-1/2 (165)	33 (15)	37 (17)	41 (19)	45 (20)
1-1/2 (38)	7-1/4 (184)	6-7/8 (175)	7-3/8 (187)	8 (203)	8 (203)	8-3/4 (222)	4-3/8 (111)	5-1/8 (130)	4-3/8 (111)	5 (127)	--	7-1/8 (181)	43 (20)	47 (21)	55 (25)	58 (26)
2 (51)	7-1/2 (191)	8-1/2 (216)	9 (229)	10-1/4 (260)	10-1/4 (260)	9-7/8 (251)	5-1/4 (133)	5-3/4 (146)	5 (127)	5-5/8 (143)	5-3/4 (146)	7-5/8 (194)	62 (28)	73 (33)	78 (35)	83 (38)
2 1/2 (64)	--	9-3/8 (238)	10 (254)	11-1/4 (286)	11-1/4 (286)	10-7/8 (276)	5-3/4 (146)	7-7/8 (200)	5-1/2 (140)	6-3/8 (152)	8-1/4 (210)	8-3/8 (213)	--	95 (43)	100 (45)	130 (59)
3 (76)	--	10 (254)	10-3/4 (273)	12-1/4 (311)	12-1/4 (311)	11-3/4 (298)	6-5/8 (168)	9-1/8 (232)	6-3/8 (162)	7-1/8 (181)	--	9-1/4 (235)	--	125 (57)	140 (64)	175 (79)
4 (102)	--	11-7/8 (302)	12-1/2 (318)	12-1/2 (318)	14-1/2 (368)	14-3/4 (375)	7-5/8 (194)	10-5/8 (270)	7-1/4 (184)	8 (203)	--	11-7/8 (302)	--	210 (95)	230 (104)	310 (141)
5 (127)	--	13-5/8 (346)	14-1/2 (368)	14-1/2 (368)	14-1/2 (368)	16-7/8 (429)	8-1/2 (216)	12-1/2 (318)	8-1/8 (206)	8-1/2 (216)	--	12-1/2 (318)	--	295 (134)	310 (141)	490 (222)
6 (152)	--	15-1/8 (384)	16 (406)	16 (406)	17-3/8 (441)	19-3/4 (502)	10 (254)	13-3/4 (349)	9-1/2 (241)	9-1/2 (241)	13-5/8 (346)	14-1/8 (359)	--	420 (191)	470 (213)	655 (297)
8 (203)	--	19 (483)	20 (508)	20 (508)	21-5/8 (549)	22-1/2 (572)	11-1/2 (292)	15-3/8 (391)	11-3/4 (298)	11-3/4 (298)	--	17-1/4 (438)	--	700 (318)	710 (322)	1070 (485)
10 (254)	--	23-5/8 (600)	25 (635)	25 (635)	--	28 (711)	13-3/4 (349)	--	--	--	--	23-3/8 (594)	--	1240 (562)	1300 (590)	--
12 (305)	--	26-1/2 (673)	28 (711)	28 (711)	--	33 (838)	15-7/8 (403)	--	--	--	--	25-1/4 (611)	--	2060 (934)	2140 (971)	--

*Add 65% to D dimension for stem removal clearance.

TYPE E2 MAIN VALVE

LOW PRESSURE / LOW DIFFERENTIAL

SIZE 3/4" - 10"
PRESSURES TO 15 PSIG AT 250°F

- Normally Closed
- Single Seat
- Nitrile Diaphragm
- Protected Main Spring
- Gas and Steam Applications
- Accurate Regulation Unaffected by Service Conditions
- ANSI/FCI 70-3 Class IV Shutoff
- Virtually Frictionless for Long Service Life
- Packless Construction
- Easy In-line Maintenance
- Wide Variety of Pilots for Many Applications
- 3 psi (.2 bar) Minimum Differential Pressure to Operate



TYPE E2 MAIN VALVE
SIZING INFO PAGE 93

APPLICATION DATA

- Pressure Regulating for Steam Distribution
- Regulating for Process Control (Temperature or Pressure)
- Maintain Back Pressure or Differential Pressure
- For use with Self-contained, Pneumatic or Electronic Pilots
- Single Point or Multiple Use Applications
- Slow Start-up or Shutdown

OPTIONS

- Composition Disc for liquid, air or gas service
- Insulcap Insulating Jacket • Integral Mount Pilot
- EZ Connections

TYPICAL CONFIGURATIONS

PRESSURE REDUCINGTYPE E2D
 AIR ADJUSTEDTYPE E2A SERIES
 BACK PRESSURETYPE E2Q
 SOLENOID CONTROLLEDTYPE E2MD
 SOLENOID ACTUATED.....TYPE E2M
 DIFFERENTIALTYPE E2N
 TEMPERATURE CONTROLTYPE E2T14
 TEMP. AND PRESSURE CONTROL.....TYPE E2T134

VALVE RATINGS

Valve Ends	Pressure	Temperature
ASME/ANSI	PSIG (bar)	°F (°C)
CAST IRON		
NPT or BSPT (Threaded)	15 (1.03)	250 (121)
CL125 FF (Flanged)	15 (1.03)	250 (121)

Canadian Registration # 0C19760

RATED FLOW COEFFICIENTS (Cv)

SEAT FACTOR	REGULATOR SIZE											
	3/4	1	1-1/4	1-1/2	2	2-1/2	3	4	5	6	8	10
Full	7.6	11.7	18.9	27.4	44	68	96	143	202	255	465	748
70%-75%	--	8.8	13.2	19.2	30.8	47.6	67.2	100	141	178	--	--
46%	--	--	--	12.3	--	30.6	--	64.4	--	115	--	336

TYPE E2 MAIN VALVE

SPECIFICATION

The valve shall be self-contained, external pilot type, single seated, Nitrile diaphragm actuated, normally closed design. The valve will function quickly and shut on dead end service. Internal parts including seats, discs and stems shall be of stainless steel. There shall be no springs in the steam flow path and no stuffing box. The valve shall be easy to maintain with all parts accessible without removal from the line.

MATERIALS OF CONSTRUCTION

Body, Cast Iron ASTMA125 Cl. B
 Stem.....303 St. Stl. ASTM A582
 Disc 3/4 - 2"420 St. Stl ASTM A743 CA-40
 Disc 2-1/2 - 10"304 St. Stl. ASTM A167/A240
 Seat420 St. Stl. ASTM A743 CA-40
 GasketGraphite
 Diaphragm.....Nitrile
 Spring.....Steel

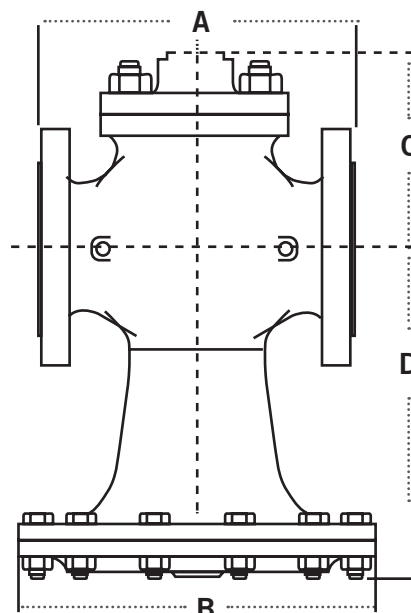

TYPE E2 MAIN VALVE

FITTINGS ON PAGE 34

DIMENSIONS, in. (mm) AND WEIGHTS, lbs (kg)

SIZE	A		B	OTHER DIMENSION		D*	APPROX. WT.	
	ANSI NPT	ANSI 125		C			ANSI NPT	ANSI 125
				Std. Mount	Integral Mount			
3/4 (19)	4-3/4 (121)	-- --	8 (203)	2-7/8 (73)	3-5/8 (92)	7-3/4 (149)	18 (8)	-- --
1 (25)	5-3/8 (137)	5-1/2 (140)	8 (203)	3-5/8 (92)	4-3/8 (111)	8-1/8 (206)	19 (9)	21 (10)
1-1/4 (32)	6-1/2 (165)	6-3/4 (171)	9 (229)	4-1/8 (105)	4 (101)	8-1/4 (210)	30 (14)	33 (15)
1-1/2 (28)	7-1/4 (184)	6-7/8 (175)	9-3/4 (248)	4-3/8 (111)	4-1/2 (118)	8-3/4 (222)	36 (16)	40 (18)
2 (51)	7-1/2 (191)	8-1/2 (216)	10-1/2 (267)	5-1/4 (133)	5 (127)	10 (254)	50 (23)	57 (26)
2-1/2 (64)	-- --	9-3/8 (238)	10-1/2 (267)	5-3/4 (146)	5-3/8 (136)	11-1/2 (292)	-- --	70 (32)
3 (76)	-- --	10 (254)	11-1/4 (286)	6-5/8 (168)	6-3/8 (162)	12-3/4 (324)	-- --	98 (45)
4 (102)	-- --	11-7/8 (302)	13-1/2 (343)	6-3/4 (171)	6-5/8 (168)	13-5/8 (346)	-- --	135 (61)
5 (127)	-- --	13-5/8 (346)	14-1/4 (362)	7-1/2 (191)	7-3/8 (187)	15 (381)	-- --	185 (84)
6 (152)	-- --	15-1/8 (384)	16 (406)	7-7/8 (200)	7 (178)	16-5/8 (422)	-- --	250 (114)
8 (203)	-- --	19 (483)	20 (508)	9-1/2 (241)	9-1/4 (235)	19-7/8 (505)	-- --	415 (189)
10 (254)	-- --	23-5/8 (600)	24 (610)	10-7/8 (276)	-- --	23-7/8 (606)	-- --	690 (314)

*Add 55% to D dimension for stem removal clearance.

TYPE E5 MAIN VALVE

HIGH PRESSURE-HIGH LIFT LOW DIFFERENTIAL

MAIN VALVES

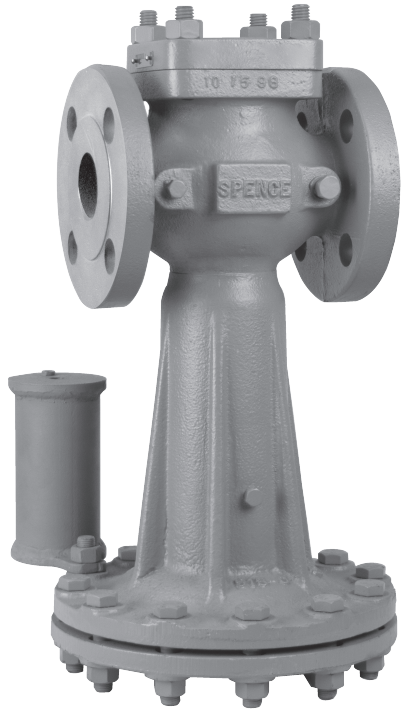

TYPE E5 MAIN VALVE
SIZING INFO PAGE 93

SIZE 3/4" - 12"
PRESSURES TO 300 PSIG AT 600°F

- Normally Closed
- Single Seat
- Balanced Nitrile Diaphragm
- Protected Main Spring
- Long Main Spring Operates on 5 psi Minimum Differential
- Internal and External Condensation Chambers
- Fluid, Gas and Vapor Applications
- Accurate Regulation Unaffected by Service Conditions
- ANSI/FCI 70-3 Class IV Shutoff
- Virtually Frictionless for Long Service Life
- Packless Construction
- Easy In-line Maintenance
- Wide Variety of Pilots for Many Applications

APPLICATION DATA

- Pressure Regulating for Steam Distribution
- High Pressure / Low Differential Pressure Regulating
- Fluid Regulation
- For use with Self-contained, Pneumatic or Electronic
- Slow Start-up or Shutdown

VALVE RATINGS

Valve Ends	Pressure	Temperature
ASME/ANSI	PSIG (bar)	°F (°C)

CAST IRON

NPT or BSPT	250(17.2) @	406 (207)
CL125 FF	125(8.6) @	450 (232)
CL250 RF	250(17.2) @	450 (232)

CAST STEEL

NPT or SWE	300(21.0) @	600 (315)
CL150 RF	150(10.3) @	500 (260)
CL300 RF	300(21.0) @	600 (315)

Other pressure/temperature ratings available; consult factory
Maximum downstream pressure is 300 psi.

Canadian Registration # 0C19760

OPTIONS

- Composition Disc for liquid, air or gas service
- Balanced Construction • Secoweld
- Integral Mount Pilot • EZ Connections • Parabolic Disc

TYPICAL CONFIGURATIONS

PRESSURE REDUCING	TYPE E5D
AIR ADJUSTED	TYPE E5A
BACK PRESSURE	TYPE E5Q
SOLENOID CONTROLLED	TYPE E5MD
SOLENOID ACTUATED	TYPE E5M
DIFFERENTIAL	TYPE E5N
TEMPERATURE CONTROL	TYPE E5T

RATED FLOW COEFFICIENTS (Cv)

SEAT FACTOR	REGULATOR SIZE												
	3/4	1	1 1/4	1 1/2	2	2-1/2	3	4	5	6	8	10	12
Full	7.6	11.7	18.9	27.4	43	67	95	159	258	350	665	1018	1611
Normal	5.7	10.0	13.4	19.8	25	35	59	120	176	228	366	525	952

TYPE E5 MAIN VALVE

SPECIFICATION

The valve shall be self-contained, external pilot type, single seated, diaphragm actuated, normally closed design. The valve will function quickly and shut on dead end service. Internal parts including seats, discs and stems shall be of stainless steel. The diaphragm shall be a balanced Nitrile material for high lift. An external condensate chamber is highly recommended. Can be ordered with bends and fittings. The main valve spring shall operate on a 5 psi minimum differential. There shall be no springs in the steam flow path and no stuffing box. The valve shall be easy to maintain with all parts accessible without removal from the line.

MATERIALS OF CONSTRUCTION

Body, Cast Iron	ASTM A126 Cl. B	Seat 3/4 - 5"	420 St. Stl. ASTM A582 Cond A
Body, Cast Steel	ASTM A216 WCB	Seat 6 - 12"	316 St. Stl. ASTM A743 CF-8M
Stem	303 St. Stl. ASTM A582	Gasket	Graphite
Disc 3/4 - 5"	420 St. Stl. ASTM A582 Cond A	Diaphragm	Nitrile
Disc 6 - 12"	304 St. Stl. ASTM A167/A240	Spring	Steel

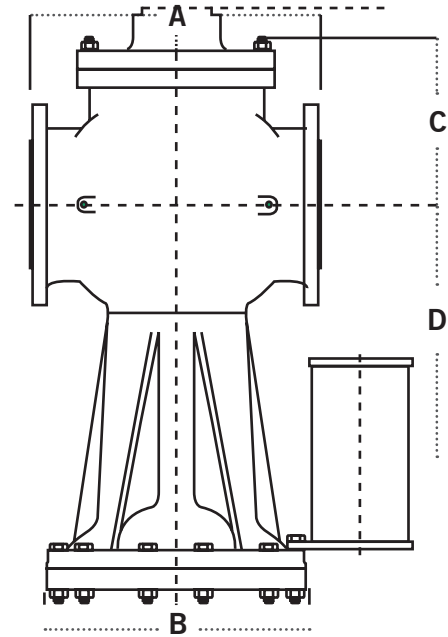

TYPE E5 MAIN VALVE

FITTINGS ON PAGE 34

DIMENSIONS, in. (mm) AND WEIGHTS, lbs (kg)

SIZE	A			B	C			D		APPROXIMATE WEIGHT				
	ANSI NPT	ANSI 125	ANSI 250		Std. Mount	Integral Mount		ANSI 125	SCR 250	Iron Stl. ANSI NPT	Iron		Steel	
						Cl	Stl.				ANSI 125	ANSI 250	ANSI 150	ANSI 300
3/4 (19)	4 3/4 (111)	--	--	6 7/8 (175)	2 7/8 (73)	3 5/8 (92)	3-1/2 (89)	11-1/4 (286)	11-1/4 (286)	23 (10)	--	--	--	--
1 (25)	5-3/8 (137)	5 1/2 (140)	6 (152)	6 7/8 (175)	3 5/8 (92)	4 3/8 (111)	4 3/8 (111)	11 5/8 (295)	11 5/8 (295)	24 (11)	30 (14)	33 (15)	35 (16)	39 (18)
1 1/4 (32)	6 1/2 (165)	6-3/4 (171)	7-1/4 (184)	9 1/8 (232)	4 1/8 (105)	4 (102)	4 5/8 (117)	13-1/2 (343)	13-1/2 (343)	49 (22)	46 (21)	49 (22)	58 (26)	63 (29)
1 1/2 (38)	7-1/4 (184)	6 7/8 (175)	7 3/8 (187)	9 1/8 (232)	4 3/8 (111)	4 1/2 (114)	5 (127)	13 5/8 (346)	13 5/8 (346)	53 (24)	58 (26)	68 (31)	67 (30)	74 (34)
2 (51)	7 1/2 (191)	8-1/2 (216)	9 (229)	11 1/8 (283)	5 1/4 (133)	5 (127)	5-5/8 (143)	16-1/4 (413)	16-1/4 (413)	84 (38)	90 (41)	97 (44)	113 (51)	120 (55)
2-1/2 (64)	--	9 3/8 (238)	10 (254)	11 1/8 (283)	5-3/4 (146)	5-3/8 (137)	6 (152)	16 1/2 (419)	16 1/2 (419)	--	97 (44)	112 (51)	130 (59)	135 (61)
3 (76)	--	10 (254)	10 3/8 (273)	13-1/2 (343)	6-5/8 (168)	5-3/8 (162)	7 (178)	19 1/4 (489)	19 1/4 (489)	--	148 (67)	170 (77)	210 (95)	226 (103)
4 (102)	--	11-7/8 (302)	12-1/2 (318)	13-1/2 (343)	7 5/8 (194)	6-5/8 (168)	8 (203)	18 3/8 (467)	233/8 (594)	--	208 (95)	293 (133)	307 (139)	330 (150)
5 (127)	--	13 5/8 (346)	14 1/2 (368)	13-1/2 (343)	8-1/2 (216)	7 3/8 (187)	8 3/4 (222)	18 3/4 (476)	233/4 (603)	--	240 (109)	333 (151)	335 (152)	366 (166)
6 (152)	--	15 1/8 (384)	16 (406)	16-3/4 (425)	10 (254)	7 (178)	--	23-1/2 (597)	273/8 (695)	--	348 (158)	616 (280)	560 (254)	503 (274)
8 (203)	--	19 (483)	20 (508)	16-3/4 (425)	11-1/2 (292)	9 1/4 (235)	--	23 3/4 (603)	295/8 (752)	--	650 (295)	814 (370)	795 (361)	862 (392)
10 (254)	--	23 5/8 (600)	25 (635)	20 (508)	13 3/4 (349)	--	--	30 3/4 (781)	35-3/8 (899)	--	910 (414)	1130 (513)	1345 (611)	1420 (645)
12 (305)	--	26 1/2 (673)	28 (711)	24 3/4 (629)	15 7/8 (403)	--	--	39 3/4 (1010)	39 3/4 (1010)	--	1580 (718)	1920 (872)	1990 (904)	2160 (982)

*Add 150% to D dimension for stem removal clearance.

MAIN VALVES

MAIN VALVE ACCESSORIES

MAIN VALVE OPTIONS

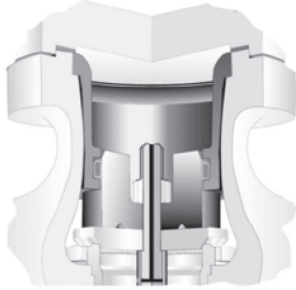

BALANCED CONSTRUCTION

There are installations where it is desirable to not have the inlet pressure forcing down on the Main Valve Disc. In these instances, the E Main Valve should be internally balanced. The balance parts allow the down-stream pressure to rest on top of the disc, thus allowing for finer adjustments in the Main Valve travel and a smoother operating regulator. The balance cylinder is suitable for 550°F max temperatures.

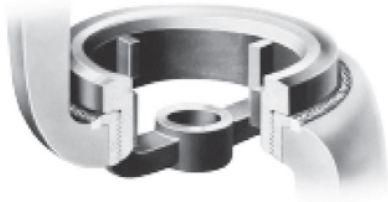

SECOWELD

The greatest weakness in a High Pressure Valve is the threaded joint between the Seat Ring and the body. A slight leak developing at this point will gradually erode the Body metal, thus accentuating the leak and eventually ruining the body. Various impractical schemes, such as welding the Seat Ring into the Body, have been tried to overcome this weakness. The invention SECOWELD solves this problem and, at the same time, provides an easily renewable Seat Ring. In the SECOWELD Design, a SECO Metal Bushing is welded to and thus sealed in the Body and, in turn, is threaded to take the Main Seat Ring, which is also of SECO Metal. As SECO Metal resists wiredrawing, if slight leakage should occur, no damage can be done to the body or to the threads of either SECO Metal piece. Consult Factory for pricing and availability.



EZ CONNECTIONS

Provides the performance of a flanged connection with the simplicity of a union connection. Unlike conventional unions, EZ Connections do not require matched sets or springing pipe to clear cone tolerances and do not leak after just a few disassembly/reassembly cycles. Uniform end to end dimensions simplify rough-in schematics. Available on 1/2" through 2" threaded main valves in NPT, socketweld and threaded by socketweld connections.

Consult Factory for pricing and availability.

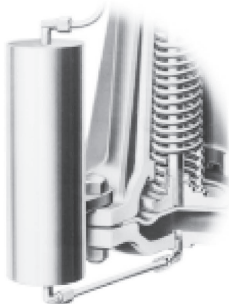

CONDENSATION CHAMBER

A Condensation Chamber is recommended on the Type E5 Main Valve. A Condensation Chamber is also recommended on the Type E Main Valve when steam temperatures exceed 600°F. Any Main Valve discharging steam into a vacuum it is recommended to install a Condensation Chamber.

MAIN VALVE OPTIONS

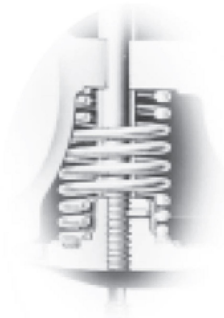

LOW DIFFERENTIAL PRESSURE (LP) MAIN SPRING

The E Series Main Valves provide superior regulation in a broad range of applications by utilizing a specialized Main Spring. When differential pressures between 10-50 psi are desired, E Main Valves should be equipped with the optional LP Main Spring. The LP Main Spring alone will achieve differential pressures to 15 psi. In order to attain differential pressures to 10 psi, optional 5B Open Elbow and 1/16" 4A Bleed Port are required.

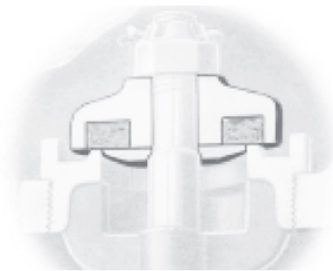

COMPOSITION DISC

In a Single Seat Main Valve, the Integral (all-metal) Disc is interchangeable with the Composition Disc Assembly. The Composition Disc is recommended for service on air, gas and water where absolutely tight shutoff is required and is available on Full and Normal seats and Parabolic valve plugs. The Composition Disc is suitable for pressures to 200 psi and temperatures to 200°F.

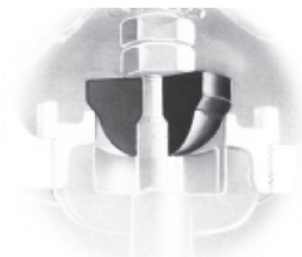

PARABOLIC DISC

In order to meet special flow requirements, any Spence Main Valve can be equipped with a Parabolic or other specially shaped Disc. Due to the fact that the Spence Main Valve is operated by a large, balanced Diaphragm and is nearly frictionless in operation, special Discs are not required on normal installations.

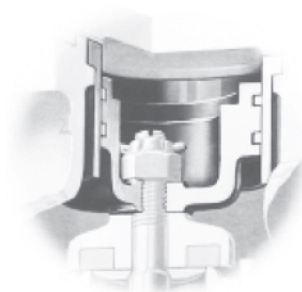

DASHPOT

In order to prevent water hammer, Dashpots are required in all single seat, normally closed Main Valves used on liquid service. Dashpots are neither necessary nor desirable on steam, air or gas service and are not required in double seat valves or in normally open single seat valves. Illustration shows Dashpot and Composition Disc for initial pressures of 200 psig and less. For initial pressures greater than 200 psig, standard metal to metal seat and disc are used.

INSULCAP SERIES

THERMAL AND ACOUSTIC BLANKET INSULATION



MAIN VALVES



INSULCAP JACKET

Temperatures to 450°F (260°C)
Average Sound Reduction of 6 dBa

- **Real Return on Investment** - 93% reduction in thermal losses over bare metal. ROI calculations available!
- **1 1/2" Thick Insulation** - Custom designs available!
- **CAD Designed and CNC Produced** - Ensures exact fit and quality coverage.
- **Thermal or Acoustic Design** - Energy saving; optional acoustic barrier provides reduction of harmful radiant noise.
- **Integral Fastener Hardware** - Flexible and easy to install, remove and reinstall.
- **Riveted Nameplate** - Ideal for large projects or sensitive industries, blankets are traceable and certifiable.

MATERIALS OF CONSTRUCTION

Core Filler ASTM C 1086-88
 Jacketing Material PTFE Coated Fiberglass Composite
 Sound Reflector ASTM E 90-90

SPECIFICATION

Blanket insulation shall be 1 1/2" thick, of 16.5 oz/yd² impregnated fiberglass cloth and mat design, with double sewn lock stitched seams, 7 stitches per inch minimum. Acoustic design shall use a barium sulfate sound reflector material, and shall be rated using ASTM E1222-87. Extended fabric flaps shall be included for overlapping of pipe insulation. Nameplate shall be of permanent design, showing location, description, size, pressure rating and sequential tag number. Fasteners shall be stainless steel, permanently affixed, and properly aligned for multiple removals and installations. Blankets shall have a stainless steel drain grommet or mating seam at lowest installed point for drainage and leak detection. Quilting pins, secured with stainless steel speed washers, shall be incorporated into the blanket at random, no greater than 18" apart.

AUXILIARY FITTINGS

BLEED PORTS

For steam, air and gas service, a 3/32" bleed port orifice is used for main valve sizes up to 8". For 10" and 12" main valve sizes, a 1/8" bleed port orifice is used. If the initial pressure or pressure drop is less than 15 psig, the orifice is reduced to 1/16". For liquids: fuel oil utilizes a 3/32" bleed port and all other fluids utilize a 1/16" bleed port regardless of pressure conditions. For main valve sizes up to 8" on long pressure drops, the orifice is sometimes increased to 1/8" to eliminate hunting or to make the valve close faster and open slower.

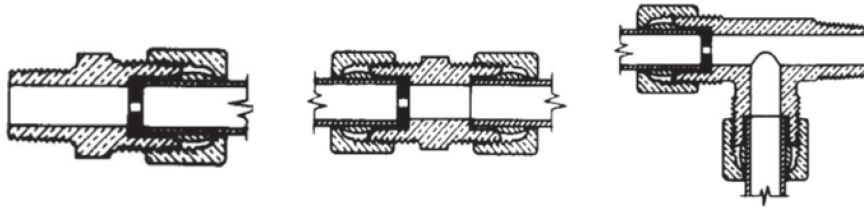

4A BLEED PORT

1A UNION BLEED PORT

8A BLEED PORT TEE

MAIN VALVE SIZE	OFFICE DRILL SIZE	DECIMAL EQUIVALENT
3/8	60	.0400
1/2	60	.0400
3/4	60	.0400
1	60	.0400
1 1/4	58	.0420
1 1/2	58	.0420
2	56	.0465
2-1/2	56	.0465
3	53	.0595
4	51	.0670
5	47	.0785
6	45	.0820
8	42	.0935
10	17	.1730
12	7	.2010

* Steam, Air and Gas.

If the initial pressure or pressure drop is less than 15 psi, a No. 5A elbow with orifice removed is used

RESTRICTIONS

Spare restriction fittings can be supplied blank and drilled for a particular main valve according to the table. If the initial pressure or pressure drop is less than 15 psi, an open fitting is used. All back pressure valves employ an open fitting. For liquid services (except back pressure) the restriction orifice is 1/16" for all sizes of main valves.



5A RESTRICTION ELBOW

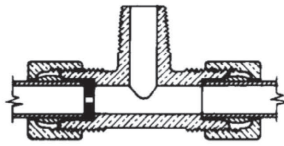

7A SAFETY PILOT RESTRICTION TEE

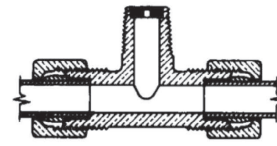

7C ANTI-FREEZE RESTRICTION TEE

OPEN FITTINGS

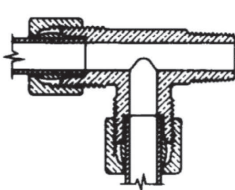

8B TEE

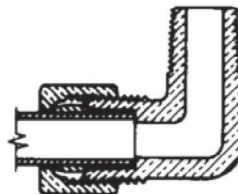

5B ELBOW

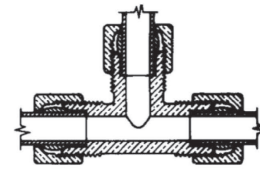

9B TUBING TEE

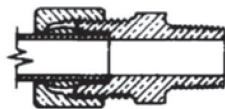

4B COUPLING

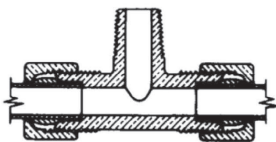

7B TEE

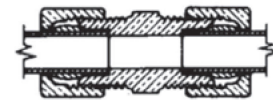

1B UNION

PILOTS

TYPE D SERIES PILOTS

PRESSURE REDUCING PILOTS

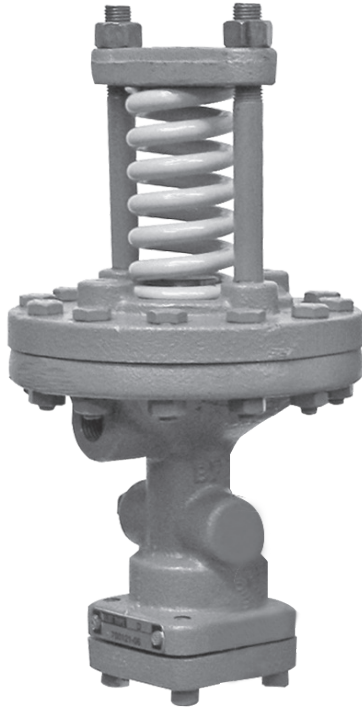

TYPE D PRESSURE PILOT

SIZING INFO PAGE 99

SPRING PRESSURE RANGE (PSIG).....

TYPE D*	TYPE D2	TYPE D5	TYPE D120
0-8	100-250	0-3	5-25
3-20	100-300	1-10	10-75
5-50		5-25	40-150
10-100			100-250
20-150			100-300

*With Vacuum Spring Assembly, minimum range is 20 inches Hg; maximum is reduced by 35 PSIG.

Canadian Registration # OC19760

TYPICAL CONFIGURATIONS.....

PRESSURE REDUCING	TYPE ED
PRESSURE REDUCING	TYPE E2D
PRESSURE REDUCING	TYPE E5D
TEMPERATURE AND PRESSURE	TYPE ET14D

CONTROLS 0 to 300 PSIG

- Self Contained
- Spring Operated
- Normally Closed
- Packless Construction
- Fluid, Gas and Vapor Applications
- Accurate Regulation Unaffected by Service Conditions
- Easy In-line Maintenance

MODELS.....

- **TYPE D** for ± 1 psi control of delivery pressures between 0 and 150 psi.
- **TYPE D2** for control of delivery pressures between 100 and 300 psi.
- **TYPE D5** for $\pm 1/2$ psi control of delivery pressures between 0 and 25 psi.
- **TYPE D120** for exceptionally fast response controlling delivery pressures between 5 and 300 psi. To be used on large E main valves.

APPLICATION DATA

- Pressure Regulating for Steam Distribution
- Regulating for Process Control
- Can be used with Temperature Pilot to Regulate Pressure on Temperature Control Application

OPTIONS

- Spring Chamber
- Adjusting Handwheel
- Composition Disc
- Integral Mount Body
- Vacuum Spring Assembly

RATING (Maximum Inlet Conditions)

Construction	Pressure	Temperature
	PSIG (bar)	°F (°C)

MATERIAL

Cast Iron	250(17.2)@	450 (232)
Cast Steel	600(41.4)@	750 (400)

TYPE D SERIES PILOTS

PRESSURE REDUCING PILOTS

SPECIFICATION

The Pilot shall be separate from the main valve and connected to it with a male union. The Pilot shall be normally closed design with packless construction. A strainer screen shall be built into the Pilot inlet. The Pilot shall be interchangeable on all sizes of main valves.

MATERIALS OF CONSTRUCTION

Body, Cast Iron	ASTM A126 Cl. B
Body, Cast Steel	ASTM A216 GR. WCB
Stem	303 St. St. ASTM A582 COND A
Disc	440 St. St. ASTM A276-75 COND A
Seat	420 St. St. ASTM A276 COND A
Gasket	Graphite
Diaphragm	301 St. St. MIL-5-5059C
Spring	Inconel

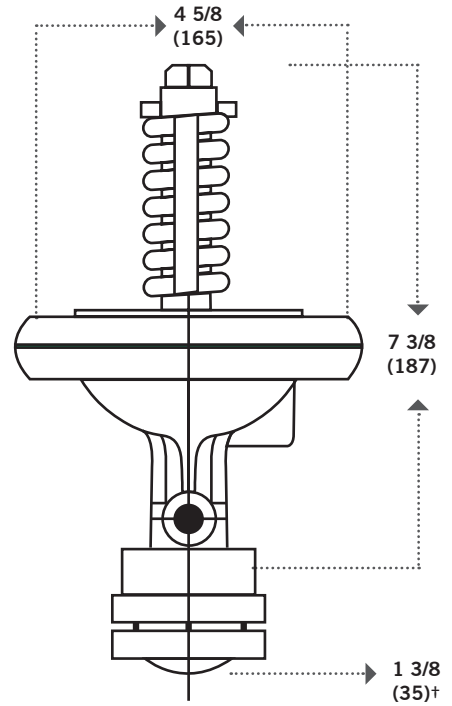

STANDARD D PILOT
7 LBS. (3.2 KG)

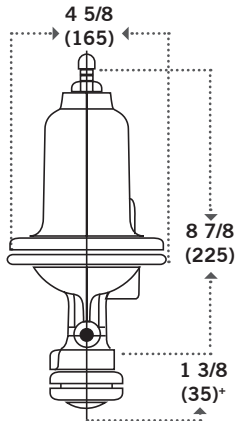

SPRING CHAMBER
8 LBS (3.6 KG)

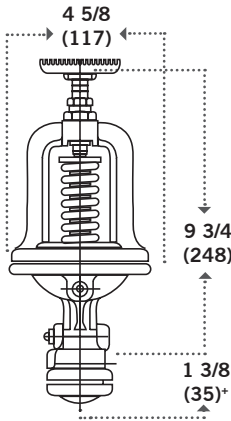

D ADJUSTING HANDWHEEL
9 LBS (4.1 KG)

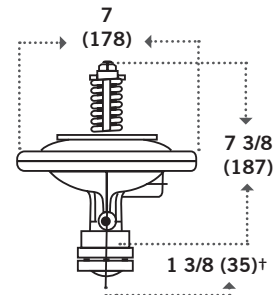

TYPE D5
14 LBS (6.4 KG)

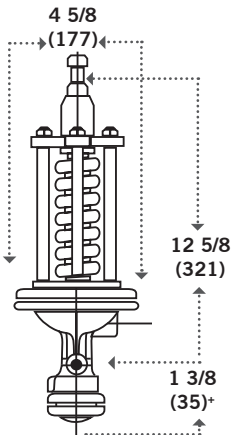

TYPE D2
10 LBS (4.5 KG)

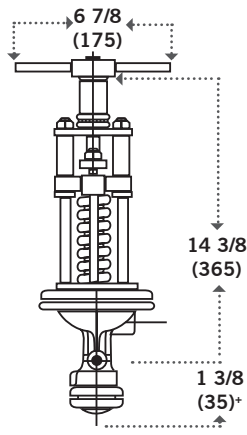

D ADJUSTING HANDWHEEL
12 LBS. (5.4 KG)

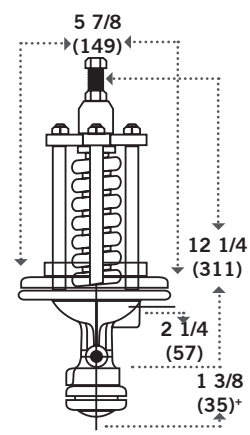

TYPE D120
16 LBS. (7.3 KG)

+ For Integral Mount Pilot, this dimension is 5/8" (16).

TYPE A SERIES PILOTS

AIR ADJUSTED PILOTS

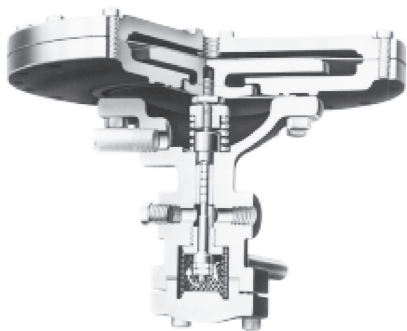

TYPE A73 AIR ADJUSTED PILOT

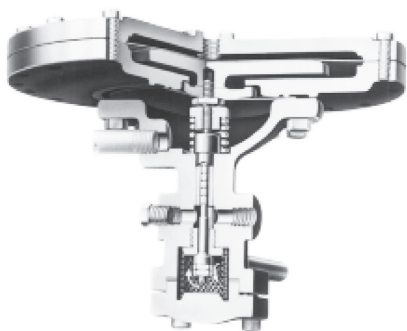

TYPE A85 AIR ADJUSTED VACUUM PILOT

SIZING INFO PAGE 99

RATING (Maximum Inlet Conditions)

Construction	Pressure PSIG (bar)	Temperature °F (°C)
--------------	------------------------	------------------------

MATERIAL

Cast Iron	250(17.2)@	450(232)
Cast Steel	600(41.4)@	600(316)

APPLICATION DATA

- Pressure Regulating for Remote Locations
- Pneumatic Pressure Control
- Pneumatic Temperature Control
- Process Control where Controller is Far from Pilot

TYPICAL CONFIGURATIONS.....

PRESSURE REDUCING	TYPE EA
PRESSURE REDUCING	TYPE E2A
PRESSURE REDUCING	TYPE E5A
TEMPERATURE AND PRESSURE	TYPE EAT61

CONTROLS 30 in. hg to 150 PSIG

- Air Loaded
- Remote Control
- Spring Operated
- Normally Closed
- Packless Construction
- Economic Use of Air
- Ease of Adjustment
- Accurate to ± 1 psi
- Delivery to Loading Air Pressure Ratios from $5/8$ to 1 up to $6\ 2/3$ to 1 psi
- Fluid, Gas and Vapor Applications
- Accurate Regulation Unaffected by Service Conditions
- Easy In-line Maintenance

OPTION

- Integral Mount

MODELS

- **TYPE A** for pressure control at low pressures. Delivery to loading pressure is 1 to 1 psi.
- **TYPE A35** for pressure control at very low delivery pressures as in some heating system control. Delivery to loading pressure is $1/2$ to 1 psi.
- **TYPE A43 and A54** for pressure control at medium to high pressures. Delivery to loading pressure is $2\ 5/8$ to 1 psi.
- **TYPE A53** for pressure control at medium pressures. Delivery to loading pressure is 4 to 1 psi.
- **TYPE A70 and A73** for pressure control at high delivery pressures when available loading air is at low pressure. Delivery to loading pressures are 15 and $6\ 2/3$ (respectively) to 1 psi.
- **TYPE A82 Vacuum** for pressure control of very low pressure or systems varying between very low pressure and light vacuum. Delivery to loading pressure is 1 to 1 psi.
- **TYPE A83 Vacuum** for temperature control. Delivery to loading pressure is 1 to 1 psi.
- **TYPE A84 Vacuum** for temperature control at lower delivery pressure features more gradual response. Delivery to loading pressure is $2\ 3/8$ to 1 psi.
- **TYPE A85 Vacuum** for temperature, pressure and vacuum control. Delivery to loading pressure is $3\ 7/8$ to 1 psi.
- **TYPE A86** for pressure control at low pressures. Delivery to loading pressure is 1 to $1\ 13/16$ psi.
- **TYPE A87 Vacuum** for temperature, pressure and vacuum control. Delivery to loading pressure is $8\ 2/3$ to 1 psi.

TYPE A SERIES PILOTS

AIR ADJUSTED PILOTS

SPECIFICATION

The Pilot shall be separate from the main valve and connected to it with a male union. The Pilot shall be normally closed design with packless construction. A strainer screen shall be built into the Pilot inlet. The Pilot shall be interchangeable on all sizes of main valves.

MATERIALS OF CONSTRUCTION

Body, Cast Iron	ASTM A126 Cl. B
Body, Cast Steel	ASTM A216 GR. WCB
Stem	303 St. St. ASTM A582 COND A
Disc	440 St. St. ASTM A276-75 COND A
Seat	420 St. St. ASTM A276 COND A
Gasket	Graphite
Diaphragm	301 St. St. MIL-5-5059C
Spring	Inconel

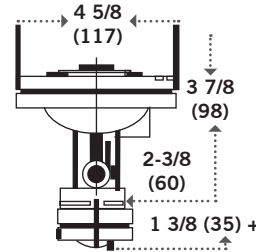

TYPE A OR A83
6 LBS (2.7 KG)

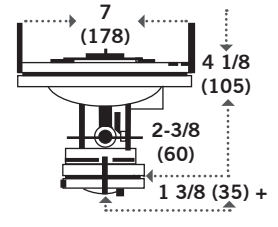

TYPE A83
11 LBS (5 KG)

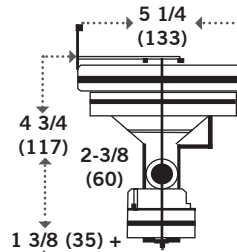

TYPE A43
11 LBS (5 KG)

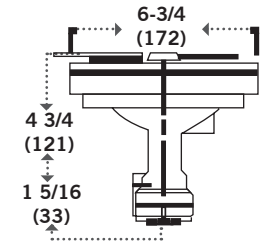

TYPE A54
19 LBS (8.6 KG)

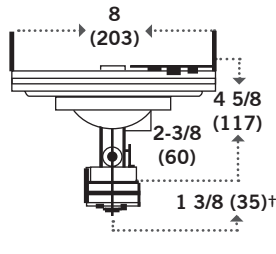

TYPE A73 OR A70
15 LBS (6.8 KG)

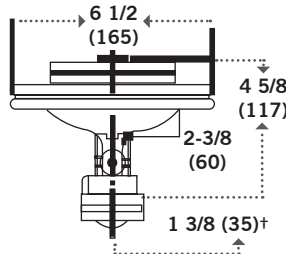

TYPE A53 OR A85
12 LBS (5.5 KG)

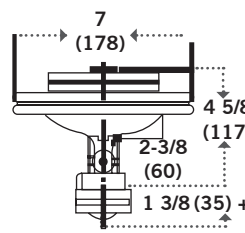

TYPE A35
14 LBS (6.4 KG)

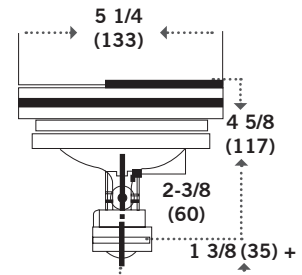

TYPE A84 OR A86
11 LBS (5 KG)

+For Integral Mount Pilot, this dimension is 5/8" (16).

PILOTS FOR POSITIVE PRESSURE

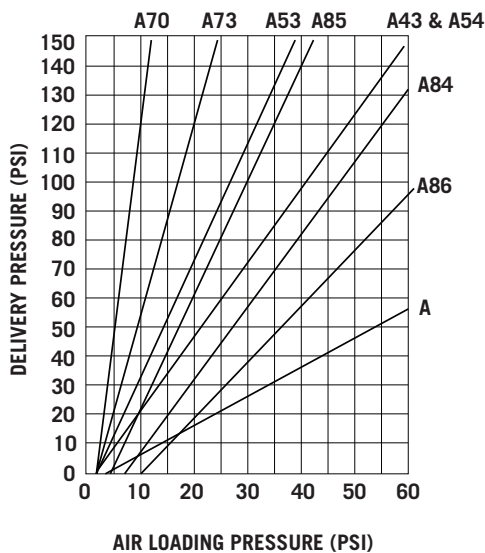

PILOTS FOR VACUUM PRESSURE

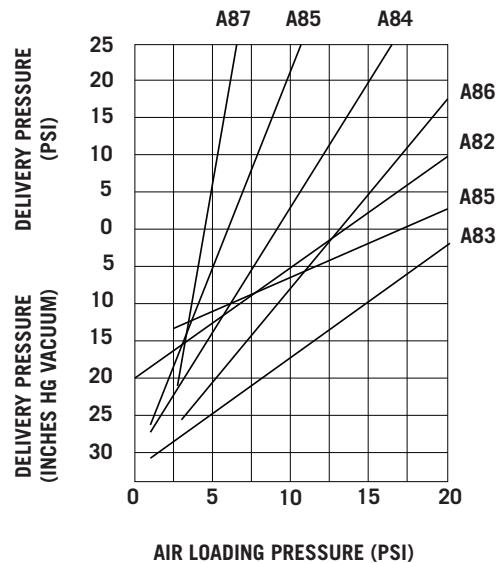

TYPE N SERIES PILOTS

DIFFERENTIAL PRESSURE PILOTS

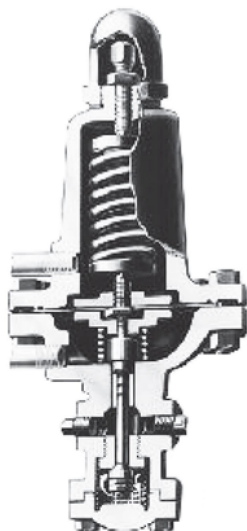

TYPE N PILOT

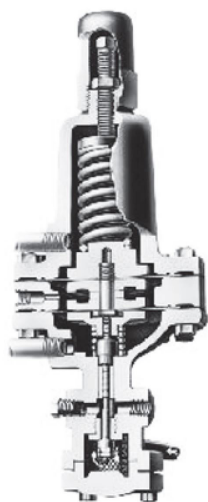

TYPE N33 PILOT
 SIZING INFO PAGE 103

SPRING PRESSURE RANGE (PSIG).....

3-20	10-100
5-50	20-150

CONTROLS 3 to 150 PSIG

- Self Contained
- Spring Operated
- Normally Closed
- Packless Construction
- Accurate to ± 1 psi
- Four Adjustable Spring Ranges
- Fluid, Gas and Vapor Applications
- Loading Pressure Supplied by any Fluid
- Accurate Regulation Unaffected by Service Conditions
- Easy In-line Maintenance

OPTIONS

- Integral Mount (for N and N33)

MODELS

- **TYPE N** for delivery pressure at set differential above loading pressure. Available in four spring ranges. Includes integral strainer.
- **TYPE N20** for fixed differential between regulator's inlet pressure and some other lower pressure.
- **TYPE N33** for delivery pressure at set differential above loading pressure where it is essential there be no mixing of two fluids. Ensured by two diaphragms, separated by a vented space. Available in four spring ranges. Includes integral strainer.

APPLICATION DATA

- Boiler Feedwater Makeup
- Steam Atomizing for Oil Burners
- Heat Exchanger to maintain Constant Differential

TYPICAL CONFIGURATIONS

PRESSURE REDUCING	TYPE EN
PRESSURE REDUCING	TYPE E2N
PRESSURE REDUCING	TYPE E5N

RATING (Maximum Inlet Conditions)

Construction	Pressure PSIG (bar)		Temperature °F (°C)
--------------	------------------------	--	------------------------

MATERIAL

Cast Iron	250(17.2)	@	450(232)
Cast Steel	600(41.4)	@	750(400)

Canadian Registration # OC19760

TYPE N SERIES PILOTS

DIFFERENTIAL PRESSURE PILOTS

SPECIFICATION

The Pilot shall be separate from the main valve and connected to it with a male union. The Pilot shall have packless construction. The Pilot shall be interchangeable on all sizes of main valves.

MATERIALS OF CONSTRUCTION

Body, Cast Iron	ASTM A126 Cl. B
Body, Cast Steel	ASTM A216 GR. WCB
Stem	303 St. St. ASTM A582 COND A
Disc	440 St. St. ASTM A276-75 COND A
Seat	420 St. St. ASTM A276 COND A
Gasket	Graphite
Diaphragm	301 St. St. MIL-5-5059C
Spring	Inconel

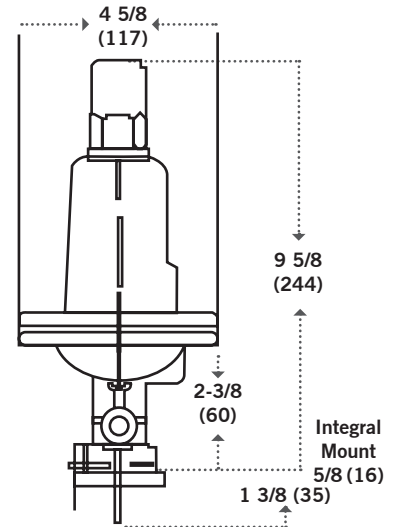

TYPE N PILOT
8 LBS (3.6 KG)

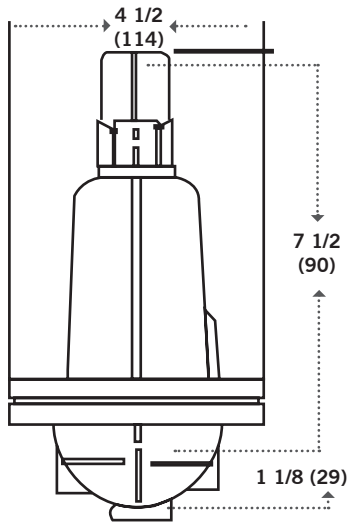

TYPE N20 PILOT
8 LBS (3.6 KG)

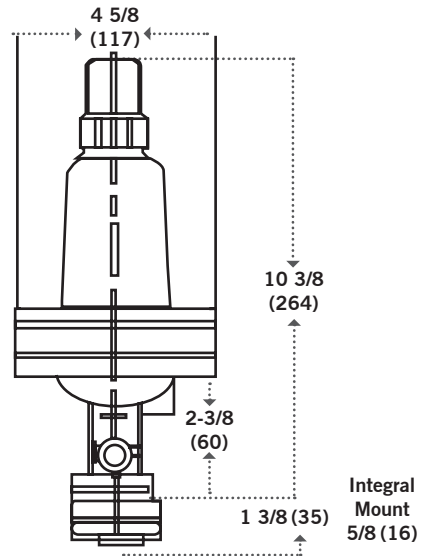

TYPE N33 PILOT
11 LBS (5 KG)

TYPE Q SERIES PILOTS

BACK PRESSURE PILOTS

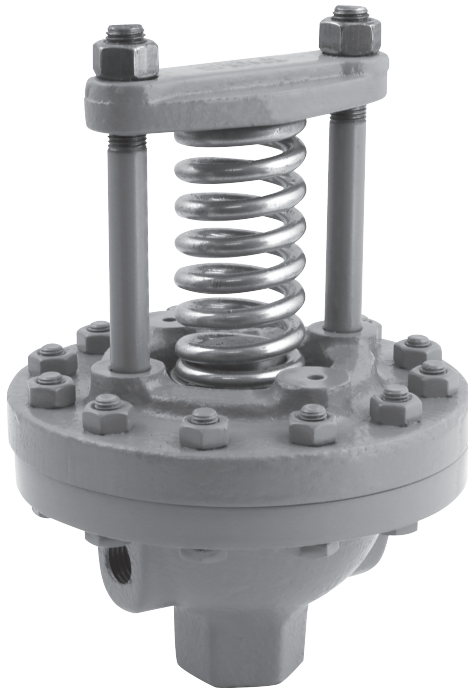

TYPE Q PILOT
SIZING INFO PAGE 104

RATING (Maximum Inlet Conditions)

Construction	Pressure PSIG (bar)	Temperature °F (°C)
--------------	------------------------	------------------------

MATERIAL

Cast Iron	150(10.3)	@ 400(204)
Cast Steel	150(10.3)	@ 500(260)

SPRING PRESSURE RANGE (PSIG)

TYPE Q	TYPE Q2
3-20	100-300
5-50	
10-100	
20-150	

Canadian Registration # OC19760

CONTROLS 3 to 300 PSIG

- Self Contained
- Spring Operated
- Normally Closed
- Packless Construction
- Adjustable Spring Ranges
- Fluid, Gas and Vapor Applications
- Loading Pressure Supplied by any Fluid
- Accurate Regulation Unaffected by Service Conditions
- Easy In-line Maintenance

OPTIONS

- Enclosed Spring Chamber
- Adjusting Handle
- High Pressure

APPLICATION DATA

- Pump Bypass
- Maintain Upstream Pressure in Steam Distribution Systems
- Maintain Upstream Pressure in Liquid Distribution Systems

MODELS

- **TYPE Q** TYPE Q for ± 1 psig accuracy controlling back pressures between 3 and 150 psig
- **TYPE Q2** for ± 2 psig accuracy controlling back pressures between 100 and 300 psig.
- **TYPE Q73** air adjusted for ± 1 psig accuracy controlling back pressure at high retained pressures when available loading air is at low pressure. Delivery to loading pressure is 6-2/3 to 1 psig

TYPICAL CONFIGURATIONS

- BACK PRESSURE CONTROL.....TYPE EQ
- BACK PRESSURE CONTROL.....TYPE E2Q
- BACK PRESSURE CONTROL TYPE E5Q

TYPE Q SERIES PILOTS

BACK PRESSURE PILOTS

SPECIFICATION

The Pilot shall be separate from the main valve and connected to it with a male union. The Pilot shall be normally closed design with packless construction. A strainer screen shall be built into the Pilot inlet. The Pilot shall be interchangeable on all sizes of main valves.

MATERIALS OF CONSTRUCTION

Body, Cast Iron ASTM A 126 Cl. B
 Body, Cast Steel ASTM A216 GR. WCB
 Disc 440 St. St. ASTM A276-75 COND A
 Seat 440 St. St. ASTM A276 COND A
 Diaphragm 301 St. St. MIL-5-5059C
 Spring Steel

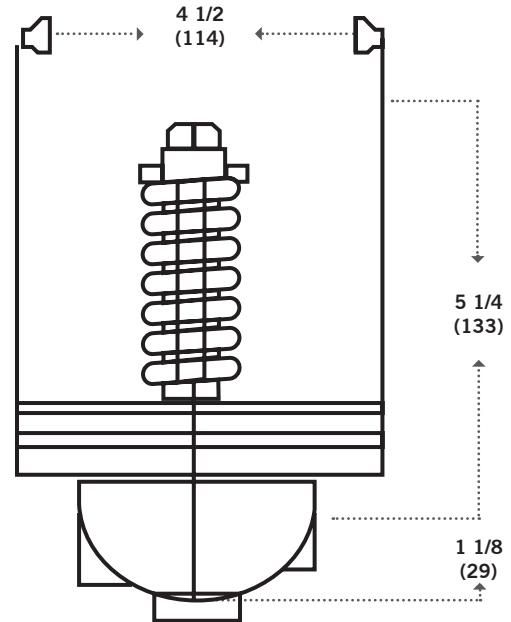

TYPE Q PILOT
7 LBS (3.2 KG)

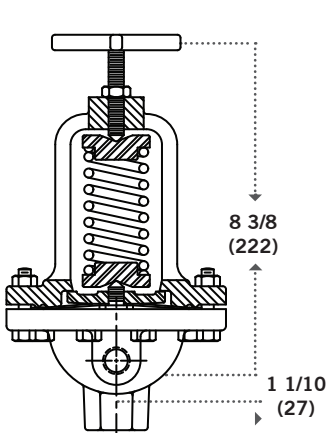

**ADJUSTING
 HANDWHEEL**

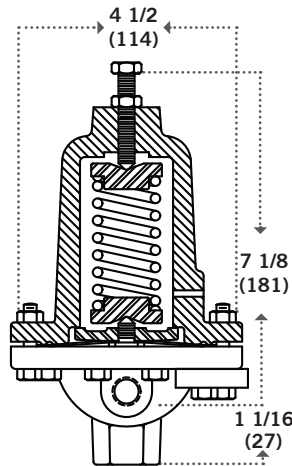

SPRING CHAMBER

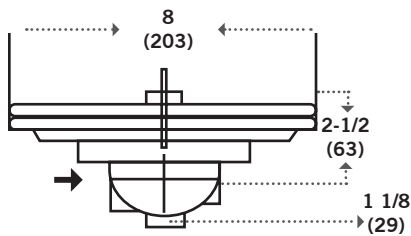

TYPE Q73 PILOT
15 LBS (6.8 KG)

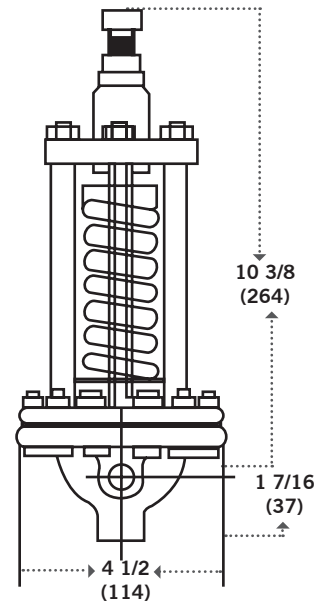

TYPE Q2 PILOT
10 LBS (4.5 KG)

PILOTS

TYPE P125 TRIP STOP PILOT



TYPE P125 TRIP STOP PILOT

RATING (Maximum Inlet Conditions)

Construction	Pressure PSIG (bar)	Temperature °F (°C)
--------------	------------------------	------------------------

MATERIAL

Cast Iron	250(17.2)@	450(232)
Cast Steel	600(41.4)@	750(400)

SHUTOFF 5 to 175 PSI

- Self Contained
- Spring Operated
- Normally Open
- Packless Construction
- Easy In-line Maintenance
- Quickly shuts off steam flow in the event of an over pressure condition
- Factory preset and tested for desired trip set point
- Trip setting unaffected by service conditions
- Manual reset feature keeps system safely shut down until control is regained

APPLICATION DATA

- Safety Shutoff For Over Pressure Conditions
- May Be Used When Conditions Disallow Use of SRV

TYPICAL CONFIGURATIONS

OVER PRESSURE SHUTDOWN.....	EP125
OVER PRESSURE SHUTDOWN.....	E5P125
OVER PRESSURE SHUTDOWN.....	E2P125

SPRING PRESSURE RANGE (PSIG)

5-25	10-50
40-150	150-175

Canadian Registration # OC 0591.9C

TYPE P125 TRIP STOP PILOT

SPECIFICATION

The Trip Stop Pilot shall be separate from the main valve and connected to it with a male union. The Pilot shall be normally closed design with packless construction. A strainer screen shall be built into the Pilot inlet. The Pilot shall be interchangeable on all sizes of main valves. The trip stop pilot shall maintain a Spence main valve in the open position while system pressure remains below set pressure. The pilot shall trip in the event of system overpressure, shutting main valve. Pilot shall be manually resettable and maintain safe shut off until reset.

MATERIALS OF CONSTRUCTION

Body, Cast Iron	ASTM A126 Cl. B
Body, Carbon Steel	ASTM 216 Gr. WCB
Stem	303 St. Stl. ASTM 582 Cond. A
Disc	440 St. Stl. ASTM 276-75 Cond. A
Seat	304 St. Stl. ASTM 276 Cond. A
Gasket	Graphite

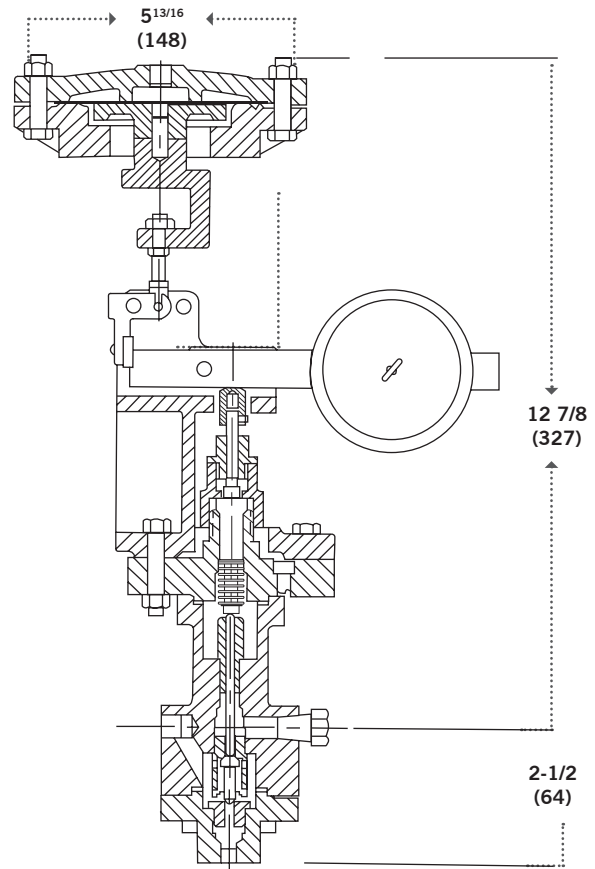

TYPE P125 TRIP STOP PILOT
CAST IRON 26 LBS. (12 KG)
CAST STEEL 28 LBS. (13 KG)

TYPE SP/P

PRESSURE SAFETY PILOT



TYPE SP/P PRESSURE SAFETY PILOT

CONTROLS to 175 PSI

- Self Contained
- Spring Operated
- Normally Closed
- Packless Construction
- Fluid, Gas and Vapor Applications
- Accurate Regulation Unaffected by Service Conditions
- Easy in-line Maintenance

APPLICATION DATA

- Where overpressure could cause personal injury or damage

TYPICAL CONFIGURATIONS

PRESSURE REDUCING.....TYPE EDSP/P
 PRESSURE REDUCING.....TYPE E5DSP/P

RATING (Maximum Inlet Conditions)

Construction	Pressure PSIG (bar)	Temperature °F (°C)
--------------	------------------------	------------------------

MATERIAL CONSTRUCTION

Bronze	250(17.2)	@	400(204)
Carbon Steel	600(41.4)	@	750(400)

SPRING PRESSURE RANGE (PSIG)

5-13	31-65	121-175
13-30	66-120	

Canadian Registration # OC19760

TYPE SP/P PRESSURE SAFETY PILOT

SPECIFICATION

Pilot to be used to prevent an accidental rise in reducing valve pressure and not to be used as substitute for a safety relief valve. Valve is normally closed. Body to be cast steel rated 600 psig 750°F or bronze rated 250 psig 400°F. Valve must provide for easy in line maintenance and of packless construction. Operating pressure range to be determined by spring selection.

MATERIALS OF CONSTRUCTION

Body, Bronze	ASTM 862 C83600
Body, Carbon Steel	ASTM 216 Gr. WCB
Stem	303 St. Stl. ASTM 582 Cond. A
Disc440 St. Stl. ASTM 276-75 Cond. A
Seat420 St. Stl. ASTM A276 Cond. A
Gasket	Graphite
Diaphragm	301 St. Stl. MIL-5-5059C
Spring	Inconel

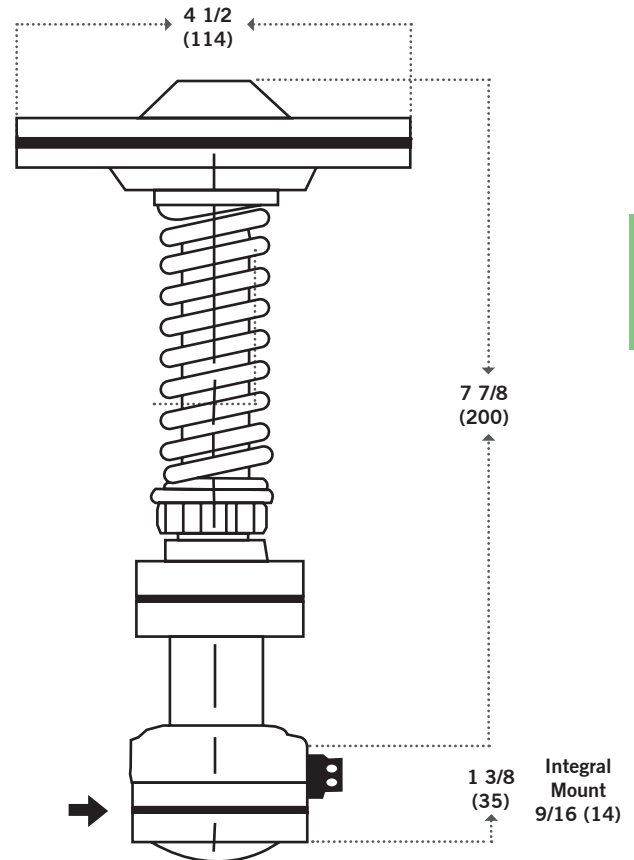

**TYPE SP/P PRESSURE
SAFETY PILOT
8 LBS. (3.6 KG)**

TYPE M SERIES PILOTS

SOLENOID PILOT



TYPE M SOLENOID PILOT

RATING (Maximum Inlet Conditions)

Model	Pressure PSIG (bar)		Temperature °F (°C)
M24, M25	250(17.2)	@	200(93)
M26, M27	125(8.6)	@	180(82)
M32LP, M33, M34LP, M35LP	125(8.6)	@	363(178)
M32HP, M33HP, M34HP	250(17.2)	@	406(208)

Canadian Registration # OC 0591.9C

CONTROLS to 250 PSI

- Fast Acting for Quick Response
- Available Normally Open or Normally Closed

MODELS*

- **TYPE M24** 3-way normally open for cold fluids in straight solenoid valve applications
- **TYPE M25** 3-way normally closed for cold fluids in straight solenoid valve applications
- **TYPE M26** 2-way normally open for cold fluids in multiple pilot arrangements
- **TYPE M27** 2-way normally closed for cold fluids in multiple pilot arrangements
- **TYPE M32** 2-way normally open for steam or other hot fluid services in multiple pilot arrangements
- **TYPE M33** 2-way normally closed for steam or other hot fluid services in multiple pilot arrangements
- **TYPE M34** 3-way normally open for steam or other hot fluid services in straight solenoid valve applications
- **TYPE M35** 3-way normally closed for steam or other hot fluid services in straight solenoid valve applications

* For M32, M33, M34, M35 Pilots, add LP suffix for low pressure and HP suffix for high pressure

APPLICATION DATA

- Remote Electronic Shutoff of Regulators

TYPICAL CONFIGURATIONS

PRESSURE REDUCING	EMD
TEMPERATURE REGULATING	EMT14
TEMPERATURE AND PRESSURE	EMT134
TEMPERATURE AND PRESSURE	EMT14D
DIFFERENTIAL PRESSURE REDUCING	E5M33N33

TYPE M SERIES PILOTS

SOLENOID PILOTS

SPECIFICATION

The actuator pilot shall open or close the controlled system via an external control signal. Actuator pilot shall be available in both fail open or fail closed upon loss of signal. Actuator pilot shall mount outside the main valve and provide remote on/off operation for a wide range of control variables.

MATERIALS OF CONSTRUCTION

Head..... Epoxy Coated aluminum (NEMA1)
 Polypropylene (NEMA 4)
 Body Brass
 Internal Core Assembly..... Ferrous and Brass
 Bonnet Gasket EPDM

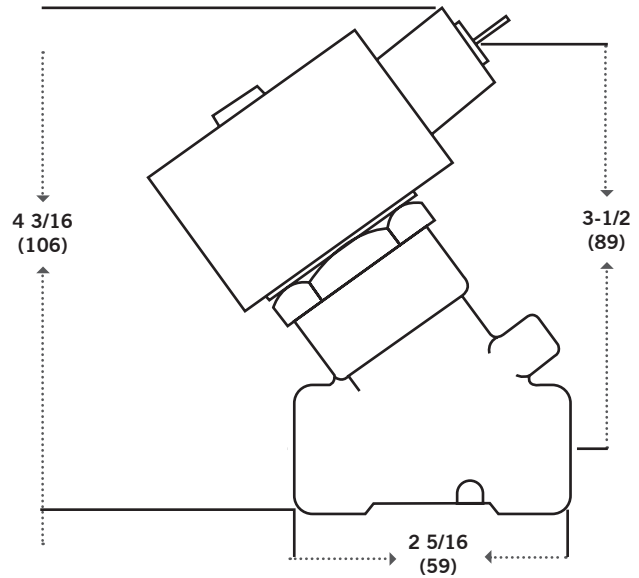

TYPE M33 SOLENOID PILOT 125#
3 LBS. (1.4 KG)

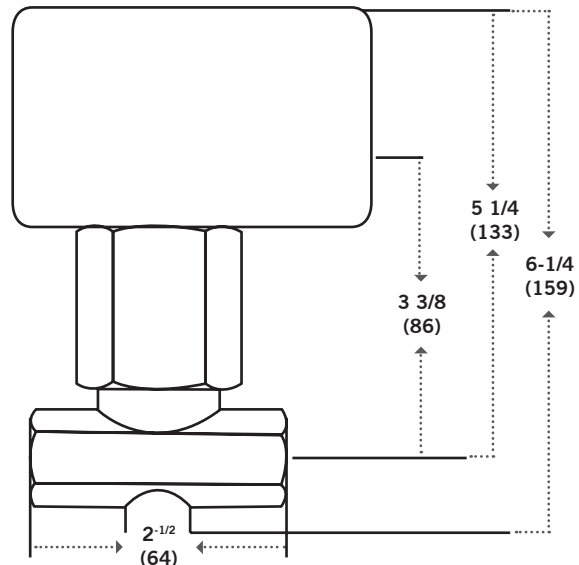

TYPE M33 SOLENOID PILOT 250#
6 LBS. (2.7 KG)

TYPE VH210 WITH ELECTRONIC TIME CONTROLLER (ETC) ELECTRONIC ACTUATOR PILOT

SPECIFICATION

The electronic actuator pilot shall maintain a system variable and modulate the valve travel in response to that system variable as requirements dictate. A continuous signal (4-20 mA, 0-10 VDC) is transmitted by the system controller to the actuator which positions the valve stem. In the event of power loss, the electronic actuator pilot shall return to a closed position.

MATERIALS OF CONSTRUCTION

Body, Cast Iron.....	ASTM 126 Cl B
Body, Steel.....	ASTM A216 GR. WCB
Stem.....	303 SS ASTM 582 Cond. A
Disc.....	440 SS ASTM 276-75 Cond. A
Seat.....	304 SS ASTM 276 Cond. A
Gasket.....	Graphite

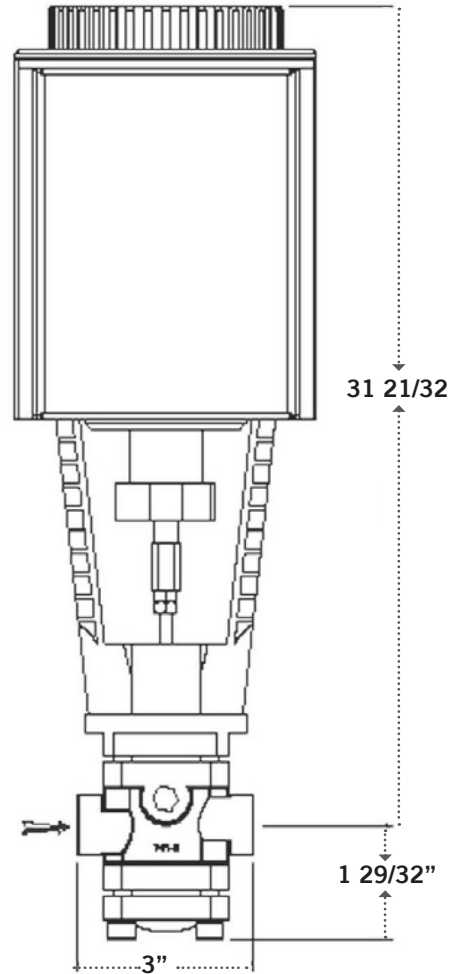
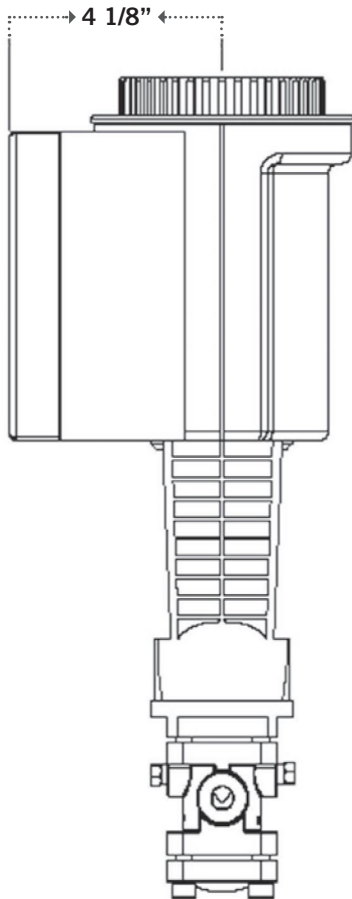

**TYPE VH210 ELECTRONIC PILOT
12.5 LBS (5.7 KG)**

TYPE T124/134

TEMPERATURE/PRESSURE PILOTS



TYPE T134
TEMPERATURE / PRESSURE PILOT

SIZING INFO PAGE 101

RATING (Maximum Inlet Conditions)

Construction	Pressure PSIG(bar)		Temperature °F(°C)
Cast Iron	250 (17.2)	@	450 (232)

TEMPERATURE RANGES (°F)

20-120	150-300
50-150	170-270
70-170	250-350
120-220	

Canadian Registration # OC19760

CONTROLS 20 to 350°F

- Precise, Rapid Response
- Vapor Tension Thermostat Spring Operated
- Self Contained
- Normally Open
- Packless Construction
- Fluid, Gas and Vapor Applications
- Strainer Screen Built-in
- Easy in-line Maintenance
- Temperature and Pressure in One Pilot

APPLICATION DATA

- Instantaneous Water Heaters
- Jacketed Kettles
- Oil Heaters
- Vats
- Storage Heaters
- Driers
- Process Heaters
- Ovens

MODELS

- **TYPE T124** for heater operating pressures between 20 and 125 psi.
- **TYPE T134** for heater operating pressures up to 20 psi.

OPTIONS

- Bronze or Stainless Thermostat
- Thermostat Well
- Tubing from 5 to 50 ft.
- Integral Mount

THERMOSTATS

700	703	713
701	704	724

TYPICAL CONFIGURATIONS

TEMPERATURE AND PRESSURE	ET124
TEMPERATURE AND PRESSURE	ET134
TEMPERATURE AND PRESSURE	E2T134
TEMPERATURE AND PRESSURE	E5T124

TYPE T124/134

TEMPERATURE/PRESSURE PILOTS

SPECIFICATION

Pilot valve shall be separate from the main valve and connected to it by unions. Pilot seats shall be protected by built-in strainer screens. Pilots shall be interchangeable on all sizes of main valves. Thermal elements shall provide a 100°F (38°C) range of temperature adjustment and shall withstand 100°F (38°C) overheating without damage. Handwheel adjustment for temperature shall be standard. Unless otherwise scheduled, thermal elements shall be equipped with 5 to 50 ft. of brass flexible tubing. Number 700 bronze bulb and number 728 bronze well shall be included except with instantaneous heaters serving intermittent demand. Steel wells shall be supplied for fuel oil service on storage tank applications.

MATERIALS OF CONSTRUCTION

Body, Cast Iron	ASTM A 126 CI B
Stem	416 St. St. ASTM A582-75
Disc	440 St. St. ASTM A582 COND A
Seat	420 St. St. ASTM A582 COND A
Gasket	Graphite
Diaphragm	301 St. St. MIL-5-5059C
Spring	Steel

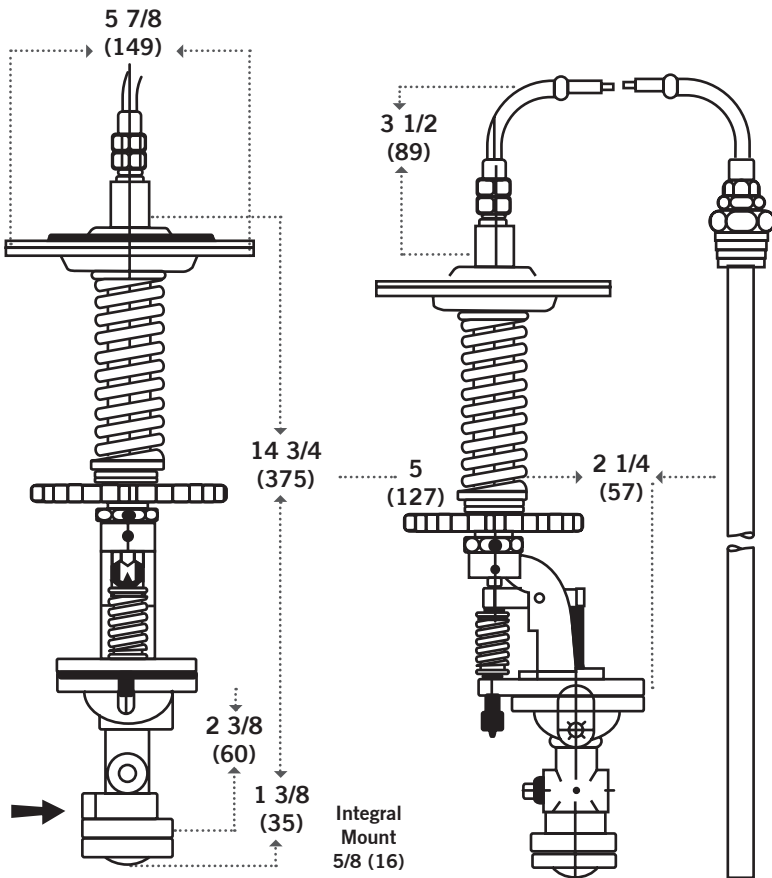

TYPE T134 PILOT
18 LBS (8.2 KG)

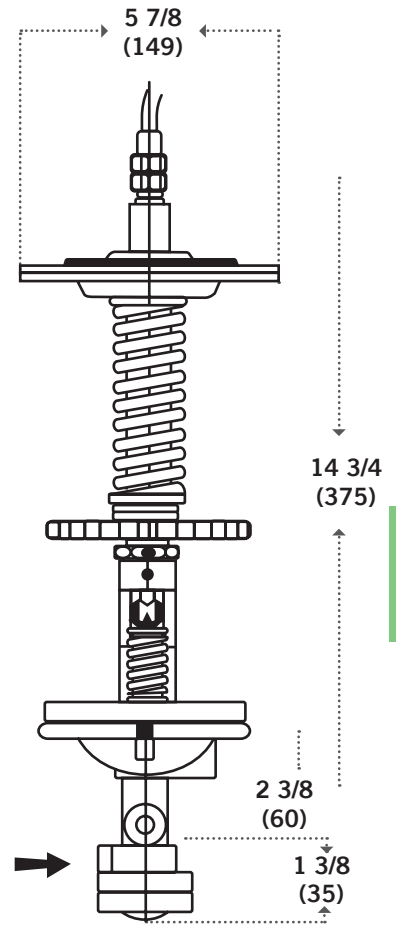

TYPE T124 PILOT
16 LBS (7.3 KG)

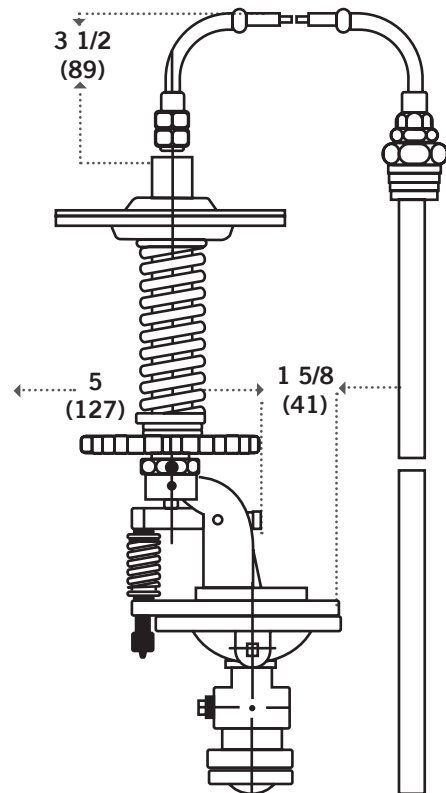

PILOTS

TYPE T14

VAPOR TENSION TEMPERATURE PILOT

CONTROLS 20 to 350°F

- Precise, Rapid Response
- Spring Operated
- Self Contained
- Normally Open, Direct Operation (Heating)
- Packless Construction
- Fluid, Gas and Vapor Applications
- Strainer Screen Built-in
- Easy in-line Maintenance

OPTIONS

- Bronze or Stainless Thermostat
- Thermostat Well
- Integral Mount
- Tubing from 5' to 50'

THERMOSTATS

700	713
701	724
703	
704	

TYPICAL CONFIGURATIONS

TEMPERATURE REGULATING.....	ET14
TEMPERATURE AND PRESSURE.....	ET14D
TEMPERATURE REGULATING.....	E2T14
TEMPERATURE AND PRESSURE.....	E2T14D
TEMPERATURE REGULATING.....	E5T14
TEMPERATURE AND PRESSURE.....	E5T14D

RATINGS (Maximum Inlet Conditions)

	Pressure	Temperature
Construction	PSIG (bar)	°F (°C)
Cast Iron	250 (17.2)	450 (232)
Cast Steel	600 (41.4)	750 (400)



TYPE T14 TEMPERATURE PILOT

APPLICATION DATA

- Storage Heater
- Jacketed Kettles
- Vats

TEMPERATURE RANGES (°F)

20-120	150-300	300-400
50-150	170-270	330-430
70-170	250-350	400-500
120-220	290-390	

Canadian Registration# OC19760

TYPE T14

VAPOR TENSION TEMPERATURE PILOT

SPECIFICATION

Pilot valve shall be separate from the main valve and connected to it by unions. Pilot seats shall be protected by built-in strainer screens. Pilot shall be interchangeable on all sizes of main valves. Thermal elements shall provide a 100°F (38°C) range of temperature adjustment and shall withstand 100°F overheating without damage. Handwheel adjustment for temperature shall be standard. Unless otherwise scheduled, thermal elements shall be equipped with 5 to 50 feet of brass flexible tubing. Number 700 bronze bulb, Number 728 bronze well shall be supplied for storage tank applications. Steel wells shall be supplied for fuel oil service.

MATERIALS OF CONSTRUCTION

Body, Cast Iron	ASTM A126 CI B
Body, Steel	ASTM A216 GR. WCB
Stem	2024-T4 ASTM 8211-75
Disc	440 St. St. ASTM A276- 75 COND A
Seat	420 St. St. ASTM A276 COND A
Gasket	Graphite
Diaphragm	Bronze ASTM 8103-77 UNS C51000
Spring	Steel

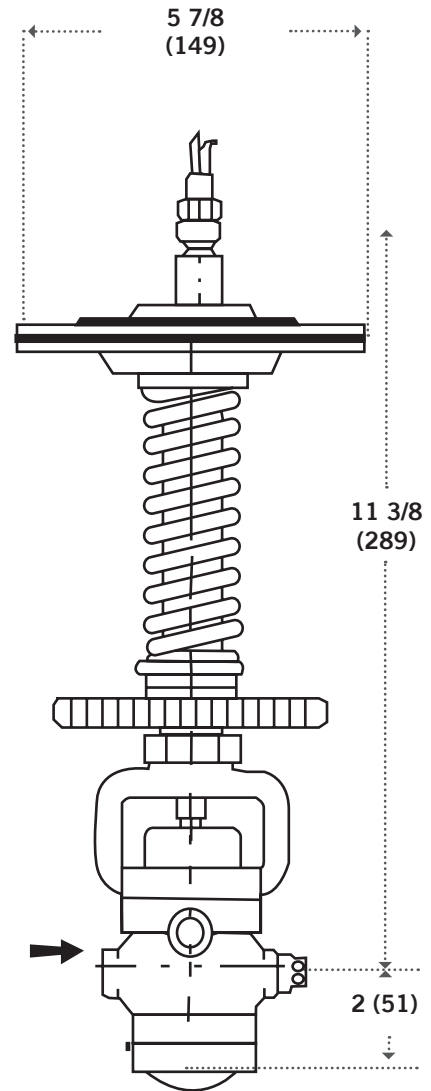
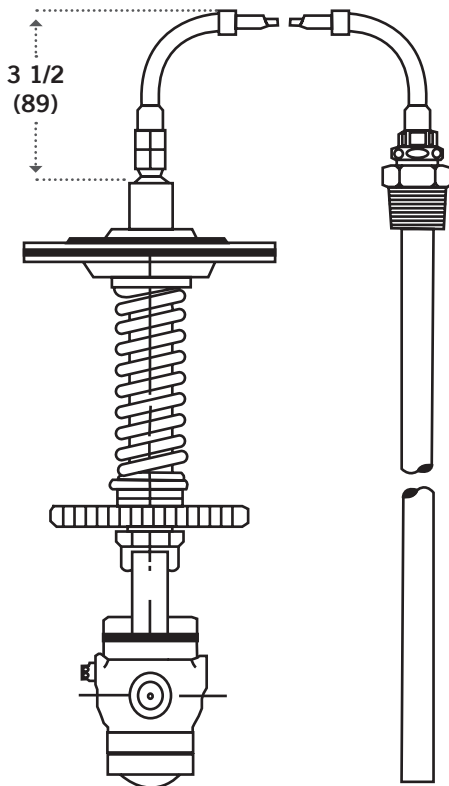

TYPE T14 TEMPERATURE PILOT
13 LBS. (6 KG)

TYPE T61 PNEUMATIC TEMPERATURE CONTROLLERS

TEMPERATURES TO 250°F

- Bimetallic Thermostat for Fast Response
- Pinpoint Accuracy
- 200°F Adjustable Temperature Range
Air Consumption - Average .25, Maximum .7
- Adjustable Proportional Band 1/4-2 psi per 1°F
- Overtemperature Protection
- Air Supply Pressure 32 psi

MODELS

- **TYPE T61** for applications where air control signal decreases as process temperature increases.



TYPE T61 PNEUMATIC TEMPERATURE CONTROLLER

APPLICATION DATA

- Instantaneous Heaters
- Process Applications with wide ranging, fast changing loads

TYPICAL CONFIGURATIONS

PRESSURE AND TEMPERATURE.....EA85T61

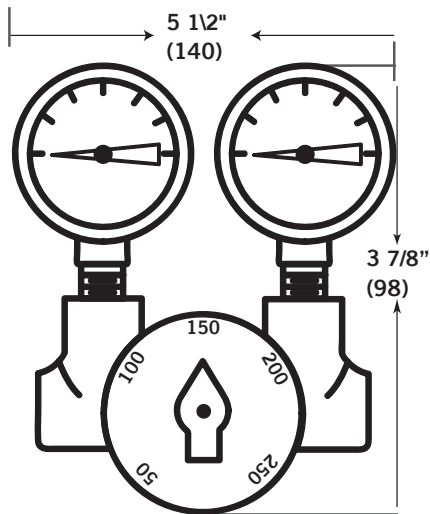

TYPE T61 CONTROLLER

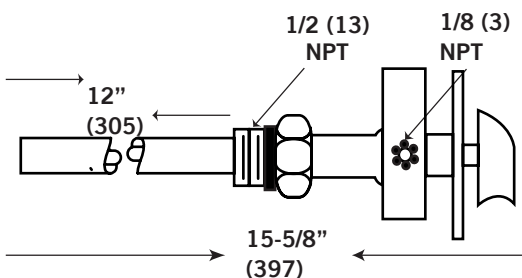

RATINGS (Maximum Inlet Conditions)

Pressure PSIG (bar)	Temperature °F (°C)
250 (17.2)	400 (204)

TEMPERATURE RANGES °F

T61	50-250
-----	--------

SPECIFICATION

The temperature controller shall be of the non-indicating type. It shall be equipped with 0-30 psi supply and loading gages. The controller shall have 200°F adjustable range and be equipped with a bronze bulb as part of its bimetal thermostat. Control point adjustments to be made by a knob on the temperature pilot and throttling range shall be adjustable externally with a set crew wrench. A stainless steel thermostat bulb, preferable in lieu of a well, is available as an alternate to bronze

MATERIALS OF CONSTRUCTION

Body.....	Brass
Body, Bulb, Bronze.....	ASTM 8140-80 UNS C31400
Body, Bulb, Steel.....	316 St. Stl. ASTM A276 Cond. A
Seals.....	Viton
Spool.....	Brass ASTM B 16-80 UNS 36000
Seat.....	304 St. Stl ASTM 276 Cond. A
Spring.....	St. Steel

MATERIAL SPECIFICATIONS FOR MAIN VALVES AND PILOTS

MAIN VALVE AND PILOT BODIES

Cast Iron.....	ASTM A 126	Class B
Cast Carbon Steel.....	ASTM A216	WCB
Cast Bronze.....	ASTM B61	C92200

STEEL PLATE FLANGES AND HOODS-FLANGE QUALITY

Carbon Steel..... ASTM A285 Grade C

NUTS

Steel Valves.....	ASTM A194- 79	Grade 2H
Cast Iron Valves.....	SAE J995	Grade 2

STUDS

Steel Valves.....	ASTM A 193-79a	Grade 2H
Cast Iron Valves.....	AISI 12L 14	Ledloy

CAP SCREWS

Cast Iron Valves	SAE J429	Grade 5
------------------	----------	---------

MATERIAL	COMPONENT PARTS	COMPONENT USAGE		
St. Steel C316 St. Steel C420 St. Steel	Seat Rings Seat Rings Seat Rings	6"-12" E Up to 5" E D34	ASTM A743-79 ASTM A743-79 ASTM A276-79a	Grade CF-8 Grade CA-40 AISI 303 & 304
St. Steel St. Steel St. Steel	Discs Discs Discs	Pilot 6" & Up, includes parabolic Up to 5"	ASTM A276-79a ASTM A276-79a ASTMA582-79	AISI 440C AISI 303 & 304 AISI 420F
St. Steel St. Steel	Stems Stems	All Valves & Pilots 750°F E, Bot. GU. VAL.	ASTM A276-79a ASTM A564-79	AISI 303 AISI 630 (17-4)
St. Steel	Diaphragms	All E's & Pilots	ASTM A167	AISI 301

PRESSURE PILOT DIAPHRAGMS

PART NO.	MATERIAL	SIZE	USED ON PILOT TYPE
WAL04-01621-0	Brz.	3 1/2"	A88, D2
WAL04-01623-0	St. Stl.	3 1/2"	D, N, Q, A43, A53
WAL04-07890-0	Brz.	3 1/2"	A35, A, A81, SP/P
WAL04-01626-0	St. St.	3 1/2"	P13, N4, F13, N24
WAL04-01627-0	Brz.	4 1/2"	A43, A84, A86, A93
WAL04-01629-1	St. Stl.	4 1/2"	Q43
WAL04-01630-0	Brz.	5-3/4"	A53, A5, A85
WAL04-01632-0	St. Stl.	5-3/4"	A92, A54
WAL04-10721-0	Brz.	5-3/4"	D5, A35
WAL04-03927-0	St. Stl.	5-3/4"	Q35, A81, A82
WAL04-01633-0	Brz.	7 1/4"	A73, A70, A75, A87
WAL04-01635-0	St. Stl.	7 1/4"	A73
WAL04-09685-0	Brz	4 1/2"	D120, A92, D234
WAL04-01659-0	St. Stl.	4 1/2"	A54

PRESSURE PILOT SPRINGS

PART NO.	DELIVERY PRESSURE	SPRING COLOR	WIRE DIAMETER	USED ON PILOT TYPE
WAL05-05007-0	1 - 10	Aluminum	3/16"	D5
WAL05-05007-0	3 - 20	Aluminum	3/16"	D5, N, N33, Q, N20
WAL05-05003-0	5 - 25	Orange	1/4"	D5
WAL05-05016-0	5 - 25	Uncolored	7/32"	D120
WAL05-05003-0	5 - 50	Orange	1/4"	D, N, N33, Q
WAL05-05028-0	10 - 75	Uncolored	5/16"	D120
WAL05-05007-0	10 - 100	Green	5/16"	D, N, N33, Q, N20
WAL05-05012-0	20 - 150	Black	11/32"	D, N, N33, Q, N20
WAL05-04990-0	100 - 300	Uncolored	7/16"	D2, N2, Q2,
WAL05-05030-0	40 - 150	Uncolored	3/8"	D120

TYPE E MAIN VALVE DIAPHRAGMS

VALVE SIZE	PART NO.		DIA.
	ST. STL.	BRZ.	
3/8 & 1/2	WAL04-01629-1	WAL04-01627-0	4 1/2
3/4	WAL04-01662-0	WAL04-01660-0	5 1/8
1	WAL04-01632-0	WAL04-01630-0	5-3/4
1 1/4	WAL04-01664-0	WAL04-09678-0	6 1/2
1 1/2	WAL04-01635-0	WAL04-01633-0	7 1/4
2	WAL04-01638-0	WAL04-09679-0	8 1/8
2-1/2	WAL04-01641-0	WAL04-09680-0	9
3	WAL05-02038-0	WAL04-09681-0	10
4	WAL05-01647-0	WAL04-09682-0	13
5	WAL05-01649-0	WAL04-09683-0	15
6	WAL05-01651-0	WAL05-09684-0	17 1/2
8	WAL05-01653-0	--	20
10	WAL04-02096-0	--	25
12	WAL05-01656-0	--	30

THE NUMBER OF E MAIN VALVE DIAPHRAGMS PER SET IS AS FOLLOWS:

Initial Pressure	#Per Set
10 - 250	2
250-400	3
400-600	4

The Number of Diaphragms per set for Pilots varies with the type and delivery pressure. Consult factory.

PILOTS

NOTES:

A series of horizontal dotted lines for taking notes.

PILOT ACCESSORIES

THERMOSTAT BULBS

FOR USE WITH T14, T124, T134 PILOTS

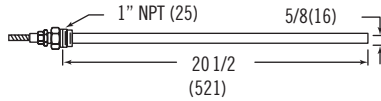

STYLE NO. 700 -Plain Bulb with 1" Union Connection.

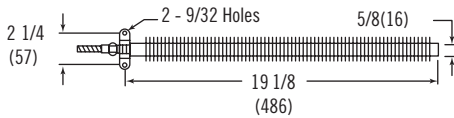

STYLE NO. 702-Finned Bulb with Wall Mounting Bracket. For space heating.

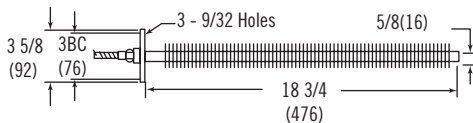

STYLE NO. 703-Finned Bulb with Duct Mounting Flange. For forced warm air heating.

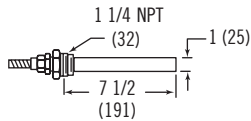

STYLE NO. 704-Plain Short Bulb with 1-1/4" Union Connection. For installations where depth is limited.

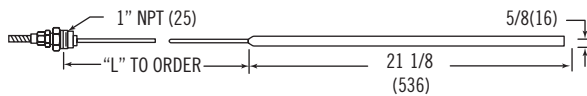

STYLE NO. 706-Plain Bulb with 1" Union Connection and 1/4" OD Bendable Extension. Dimension "L" must be specified.

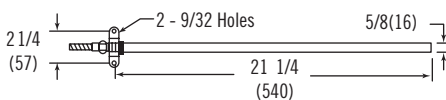

STYLE NO. 708-Plain Bulb with Wall Mounting Bracket. Used for space heating when dust is a problem.

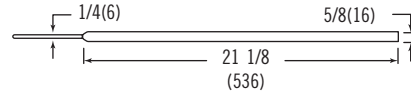

STYLE NO. 712-Plain Bulb with 1/4" OD Bendable Tubing Cover for Capillary. Used in open tanks or where a mounting connection is not required

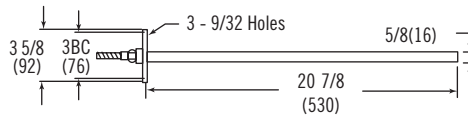

STYLE 713-Plain Bulb with Duct Mounting Flange. For forced warm air heating when dust is a problem.

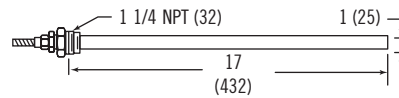

STYLE NO. 701-Large Plain bulb with 1-1/4" Union Connection. Used on pilots having more than 30 feet of flexible tubing.

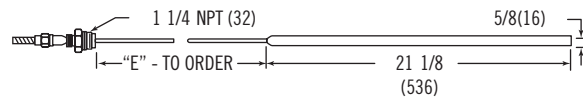

STYLE NO 731-Plain Bulb with Adjustment dimension. Used in oil storage tanks or wherever it is desirable to change position of bulb. Dimension "E" must be specified.

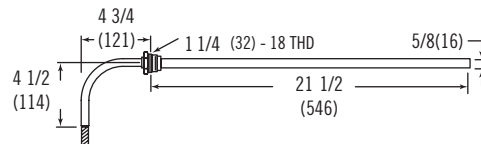

STYLE NO. 740-Sanitary Bulb for Milk Heaters. Threaded to fit standard No. 23A Thermometer Ferrule. Stainless Steel Bulb and Flexible Tubing.

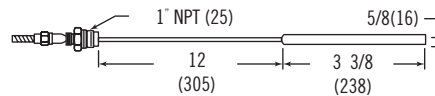

STYLE NO. 732-Special with 12" hole Extension.

THERMOSTAT WELLS

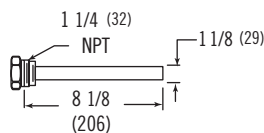

727 WELL - Used with 704 Bulb

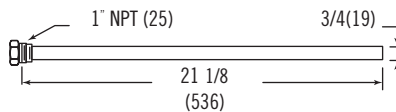

728 WELL - Used with 700 and 800 Bulb

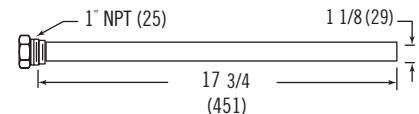

729 WELL - Used with 701 and 801 Bulb

COMBINATION REGULATORS

TYPE ED SERIES PRESSURE REGULATOR

Pressures to 600 PSIG / Temperatures to 750°F

APPLICATIONS

- Pressure Regulation for Steam Distribution
- Single Point or Multiple Use Applications
- Pressure Control for Steam Plants
- District Heating Systems
- Single Stage Reduction Stations
- Two Stage Reduction Stations
- Parallel Reduction Stations

COMBO
REGS

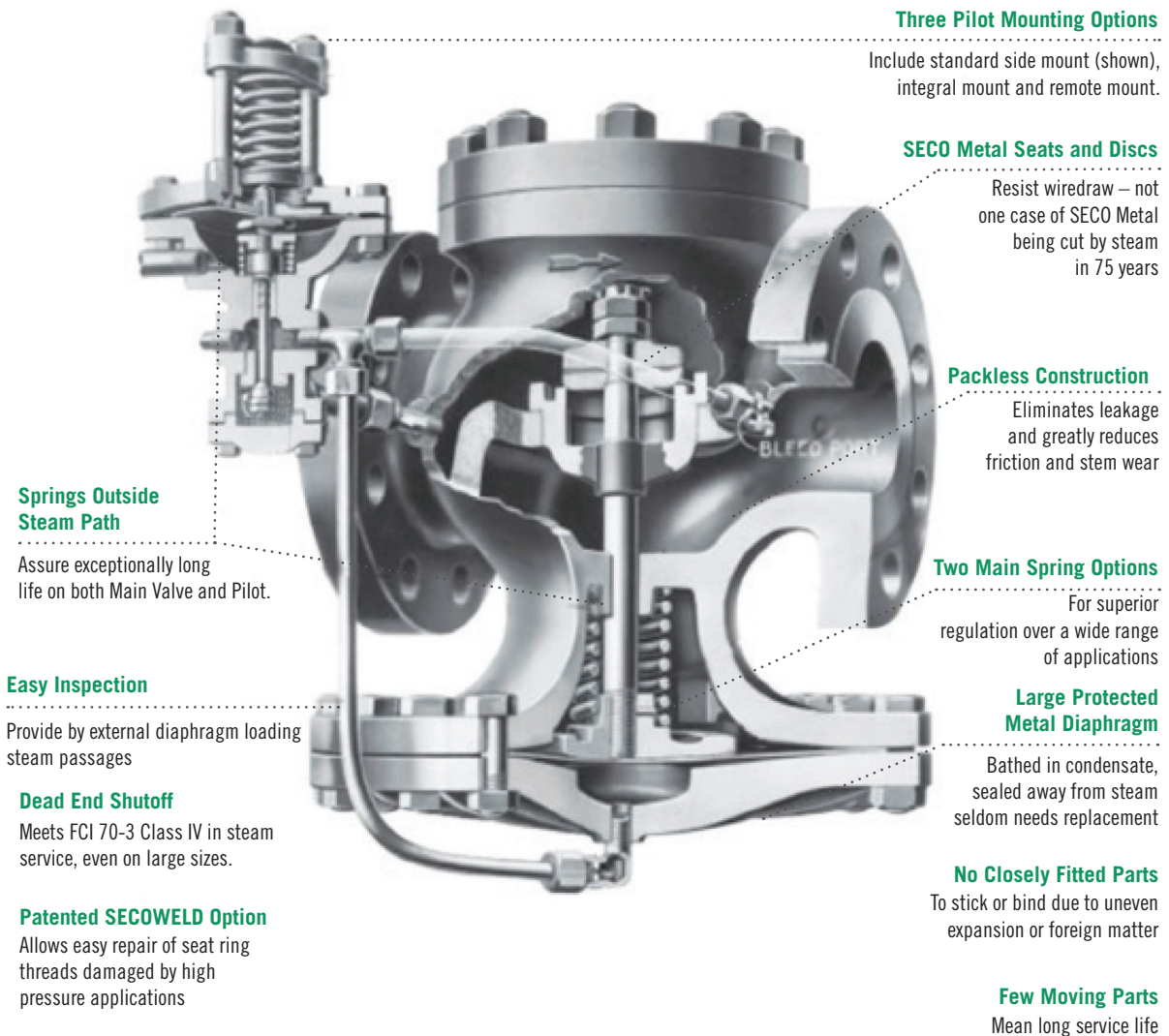

TYPE ED SERIES PRESSURE REGULATOR

CAST IRON or STEEL - Pressures to 600 PSIG at 750°F

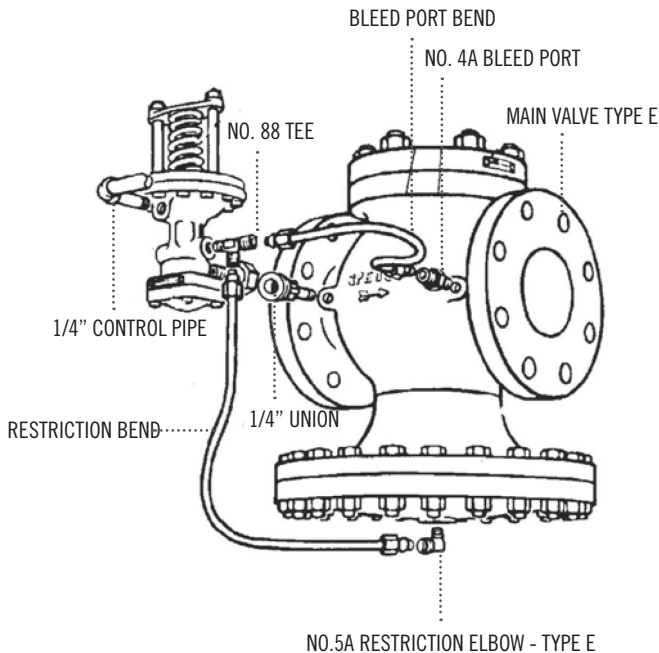
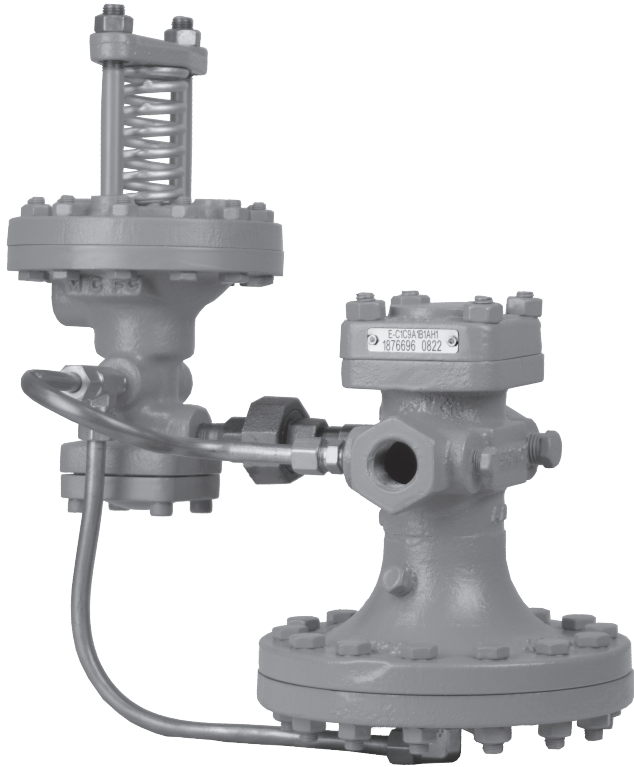

APPLICATION

- Pressure Regulation for Steam Distribution
- Single Point or Multiple use Applications
- Pressure Control for Steam Plants
- District Heating Systems
- Single Stage Reductions
- Two Stage Reductions
- Parallel Reduction

TYPE ED SERIES PRESSURE REGULATOR

VALVE INFO PAGE 22 / PILOT INFO PAGE 36

DIMENSIONS inches(mm)

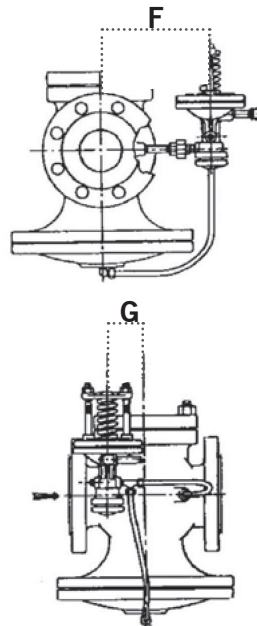

Valve is tapped so that Pilot may be mounted on either side.

SIZE	F	G
3/8 (10)	5-3/8 (136)	1-1/4 (32)
1/2 (15)	5-3/8 (136)	1-1/4 (32)
3/4 (20)	5-3/8 (136)	1-3/8 (35)
1 (25)	5-3/4 (146)	1-1/2 (38)
1-1/4 (32)	6 (152)	1-7/8 (48)
1-1/2 (40)	6-1/4 (159)	2 (51)
2 (60)	6-5/8 (168)	2-1/8 (54)
2-1/2 (65)	6-3/4 (171)	2-3/8 (60)
3 (80)	7-1/4 (184)	2-3/4 (70)
4 (100)	8 (203)	2-1/2 (89)
5 (125)	9 (229)	3-1/2 (89)
6 (150)	9-7/8 (251)	4 (102)
8 (200)	10-1/2 (267)	6-1/4 (159)
10 (250)	12-1/2 (318)	6 (152)
12 (300)	14 (356)	8-1/2 (216)

TYPE E2D SERIES PRESSURE REGULATOR

CAST IRON - PRESSURES to 15 PSIG max.

COMBO
REGS

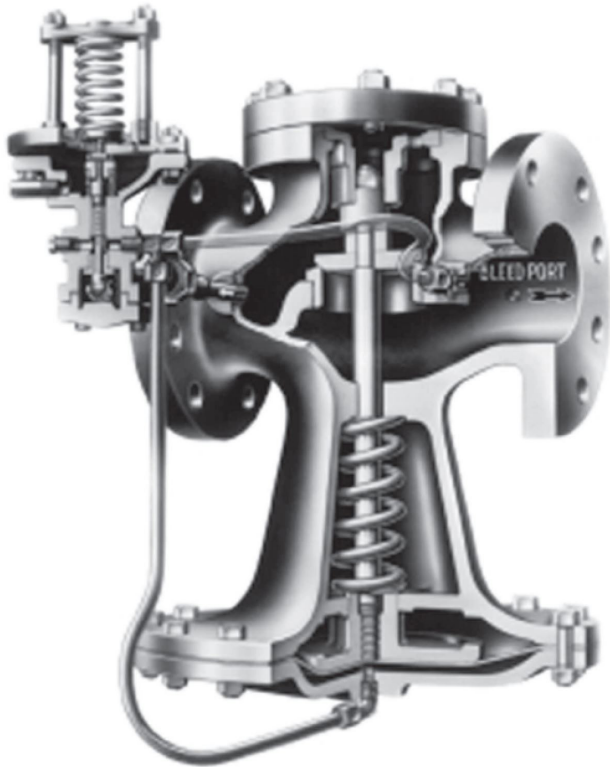

APPLICATION DATA

- Pressure Regulating for Steam Distribution
- Single Point or Multiple use Applications
- Single Stage Reduction
- Parallel Reduction
- Low Pressure Drop to Operate Valve
- Instantaneous Hot Water Heaters with low supply pressures (with the addition of a T14 pilot)

TYPE E2D PRESSURE REGULATOR

VALVE INFO PAGE 24 / PILOT INFO PAGE 36

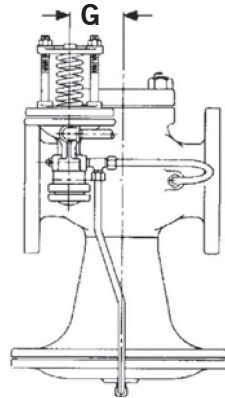
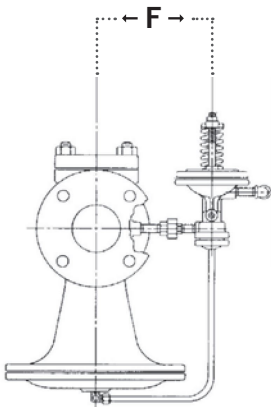

DIMENSIONS, in. (mm)

SIZE	F	G
3/4 (20)	5-5/8 (143)	1-3/8 (35)
1 (25)	5-3/4 (146)	1-1/2 (38)
1-1/4 (32)	6 (152)	1-7/8 (48)
1-1/2 (40)	6-1/4 (159)	2 (51)
2 (50)	6-5/8 (165)	2-1/8 (54)
2-1/2 (65)	6-3/4 (171)	2-3/8 (60)
3 (80)	7-1/4 (184)	2-3/4 (70)
4 (100)	7-3/8 (187)	3-1/2 (89)
5 (125)	8-1/8 (206)	3-1/2 (89)
6 (150)	8-1/2 (216)	4 (102)
8 (200)	9-3/8 (238)	6-1/4 (159)
10 (250)	11 (279)	6 (152)

Valve is tapped so that pilot may be mounted on either side.

TYPE ED AND ED2

INTEGRAL MOUNT PRESSURE REGULATOR

CAST IRON OR STEEL- Pressures to 600 PSIG at 750°F

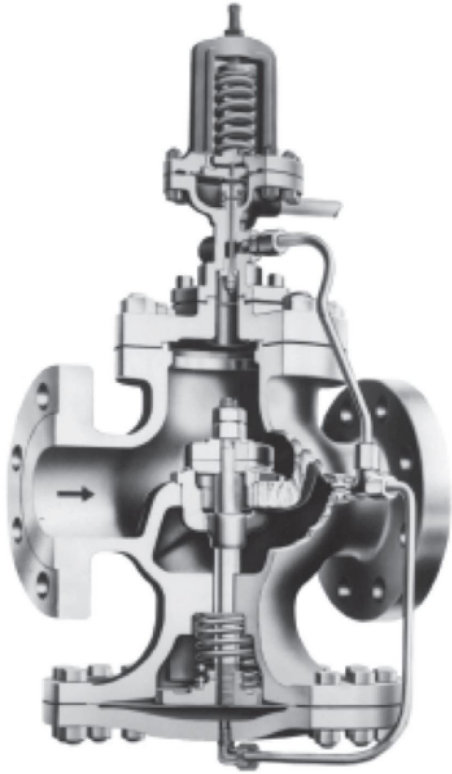

APPLICATION DATA

- Pressure Regulating for Steam Distribution where space is limited

TYPE ED INTEGRAL MOUNT PRESSURE REGULATOR

VALVE INFO PAGE 22 / PILOT INFO PAGE 36

COMBO
REGS

DIMENSIONS, in. (mm)

SIZE	F	G
3/8 (10)	5-1/4 (133)	15-3/4 (400)
1/2 (15)	5-1/4 (133)	15-3/4 (400)
3/4 (20)	5-3/8 (136)	17 (432)
1 (25)	5-1/2 (140)	18-1/2 (470)
1-1/4 (32)	5-3/4 (148)	18-1/2 (470)
1-1/2 (40)	6 (152)	19-1/2 (495)
2 (50)	6-1/2 (165)	20-5/8 (524)
2-1/2 (65)	7 (178)	21-3/4 (552)
3 (80)	7-3/8 (187)	23-1/2 (597)
4 (100)	8-7/8 (225)	27-1/4 (692)
5 (125)	10 (254)	28-5/8 (727)
6 (150)	11-3/8 (279)	31-1/2 (792)
8 (200)	12-3/4 (324)	35-3/8 (899)
10 (250)	15-1/2 (394)	43-3/4 (1111)
12 (300)	18 (457)	47-3/4 (1213)

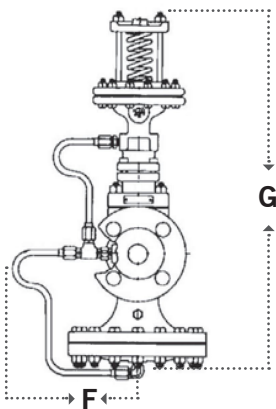

Type ED

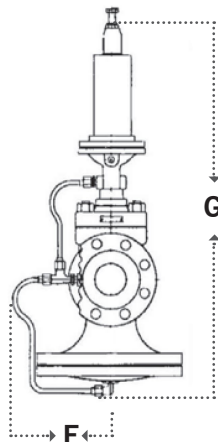

Type ED2

* For D2 Pilot, add 5 1/4" (133) to this dimension.

TYPE EA SERIES PRESSURE REGULATOR

CAST IRON or STEEL - Pressures to 600 PSIG at 750°F

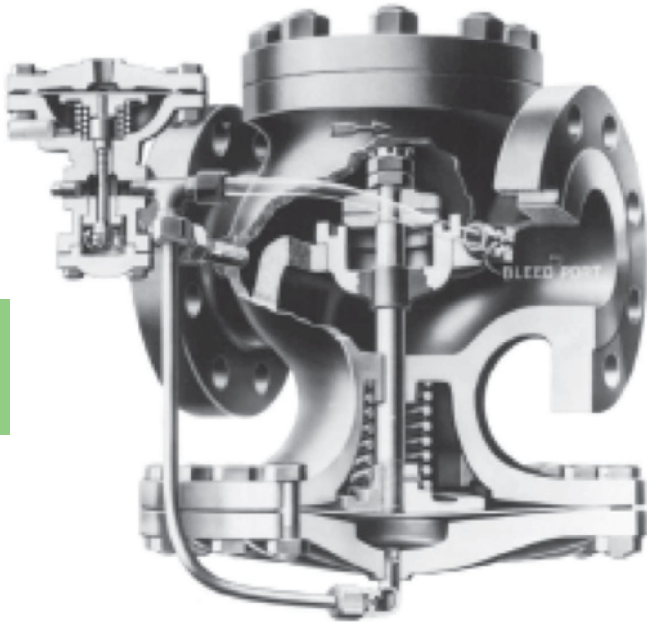

APPLICATION DATA

- Pressure Regulating for Steam Distribution
- Single Point or Multiple use Applications
- Pressure Control for Steam Plants
- District Heating Systems
- Single Stage Reductions
- Two Stage Reductions
- Parallel Reduction
- Control from Remote Location
- Temperature Regulating (with addition of T60 Series Pneumatic Temperature Pilot)

COMBO
REGS

TYPE EA PRESSURE REGULATOR

VALVE INFO PAGE 22 / PILOT INFO PAGE 38

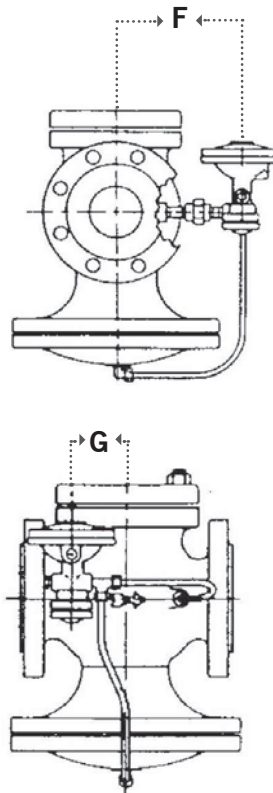
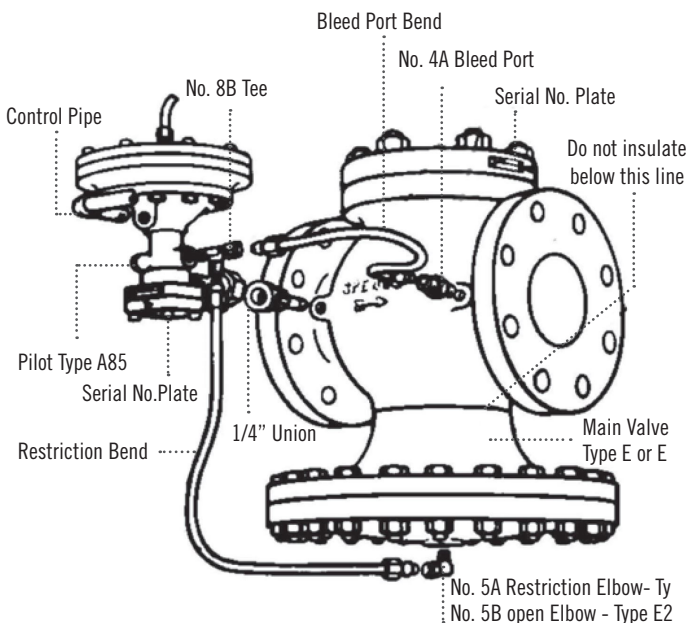

DIMENSIONS, in. (mm)

SIZE	F	G
3/8 (10)	5-3/8 (136)	1-1/4 (32)
1/2 (15)	5-5/8 (136)	1-1/4 (32)
3/4 (20)	5-3/8 (143)	1-3/8 (35)
1 (25)	5-3/4 (146)	1-1/2 (38)
1-1/4 (32)	6 (152)	1-7/8 (48)
1-1/2 (40)	6-1/4 (159)	2 (51)
2 (50)	6-5/8 (168)	2-1/8 (54)
2-1/2 (65)	6-3/4 (171)	2-3/8 (60)
3 (80)	7-1/4 (184)	2-3/4 (70)
4 (100)	8 (203)	3-1/2 (89)
5 (125)	9 (229)	3-1/2 (89)
6 (150)	9-7/8 (251)	4 (102)
8 (200)	10-1/2 (267)	6-1/4 (159)
10 (250)	12-1/2 (318)	6 (152)
12 (300)	14 (356)	8-1/2 (216)

Valve is tapped so that Pilot may be mounted on either side.

TYPE ET14 TEMPERATURE REGULATOR

CAST IRON or STEEL - Controls 20 to 500°F

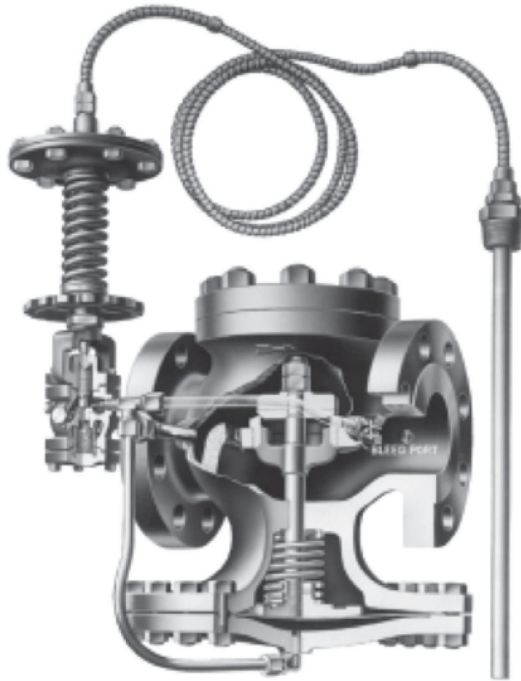

APPLICATION DATA

- Temperature Regulation for Batch Process
- Storage Heaters (Water, Fuel Oil or Chemical)
- Air Heating

TYPE ET14 TEMPERATURE REGULATOR

VALVE INFO PAGE 22 / PILOT INFO PAGE 54

COMBO
REGS

DIMENSIONS, in. (mm)

SIZE	F	G
3/8 (10)	5-3/8 (136)	1-1/4 (32)
1/2 (15)	5-3/8 (136)	1-1/4 (32)
3/4 (20)	5-5/8 (143)	1-3/8 (35)
1 (25)	5-3/4 (146)	1-1/2 (38)
1-1/4 (32)	6 (152)	1-7/8 (48)
1-1/2 (40)	6-1/4 (159)	2 (51)
2 (50)	6-5/8 (168)	2-1/8 (54)
2-1/2 (65)	6-3/4 (171)	2-3/8 (60)
3 (80)	7-1/4 (184)	2-3/4 (70)
4 (100)	8 (203)	3-1/2 (89)
5 (125)	9 (229)	3-1/2 (89)
6 (150)	9-7/8 (251)	4 (102)
8 (200)	10-1/2 (267)	6-1/4 (159)
10 (250)	12-1/2 (318)	6 (152)
12 (300)	14 (356)	8-1/2 (216)

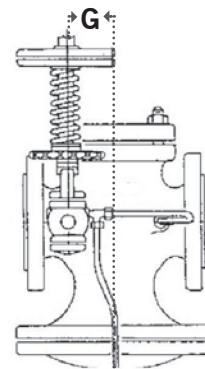
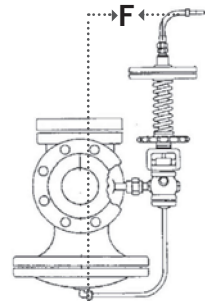

Valve is tapped so that Pilot may be mounted on either side.

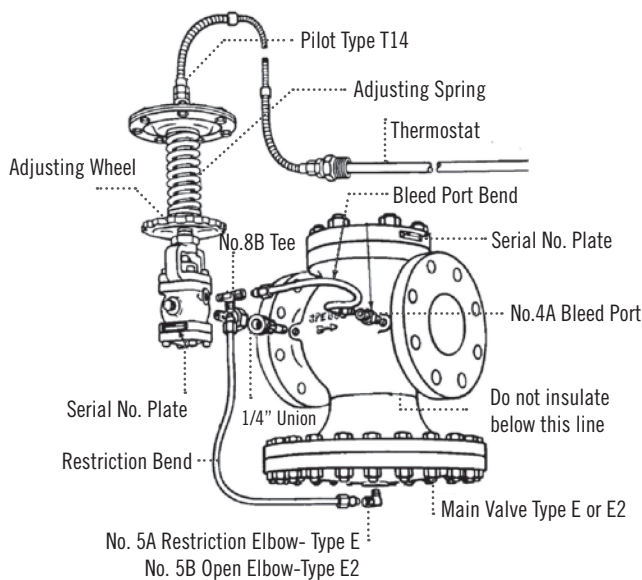

TYPE ET14D SERIES PRESSURE LIMITING TEMPERATURE REGULATOR

CAST IRON or STEEL - CONTROLS from 20°F to 500°F

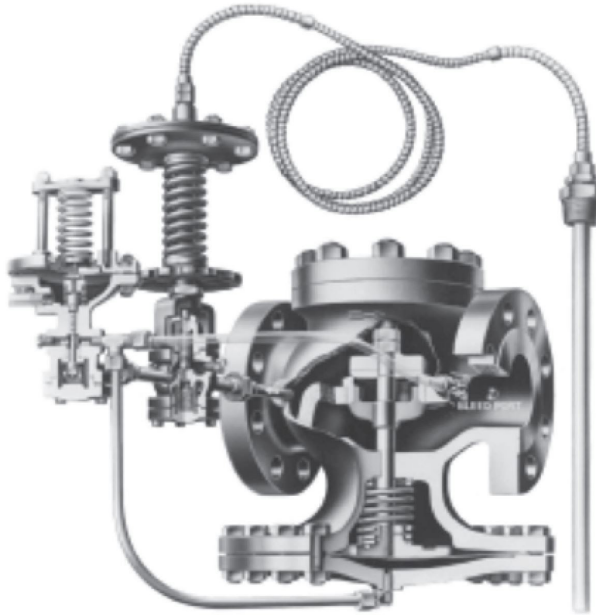

APPLICATION DATA

- Temperature and Pressure Regulation for large volume heat Exchangers
- Storage Heaters
- Jacketed Kettles
- Vats

TYPE ET14D TEMPERATURE AND PRESSURE REGULATOR

VALVE INFO PAGE 22 / D PILOT INFO PAGE 36
T14 PILOT INFO PAGE 54

COMBO
REGS

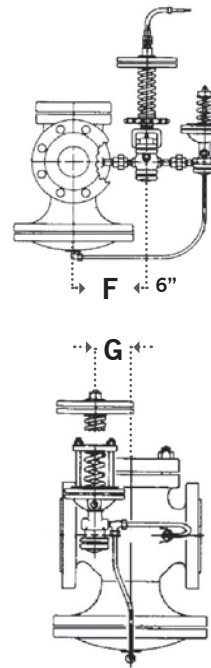
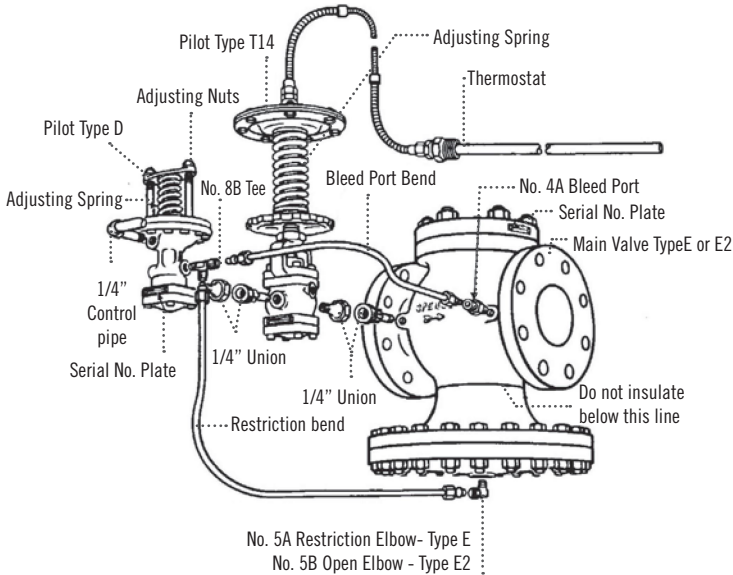

DIMENSIONS, in. (mm)

SIZE	F	G
3/8 (10)	5-3/8 (136)	1-1/4 (32)
1/2 (15)	5-3/8 (136)	1-1/4 (32)
3/4 (20)	5-3/8 (143)	1-3/8 (35)
1 (25)	5-3/8 (146)	1-1/2 (38)
1-1/4 (32)	6 (152)	1-7/8 (48)
1-1/2 (40)	6-1/4 (159)	2 (51)
2 (50)	6-5/8 (168)	2-1/8 (54)
2-1/2 (65)	6-3/4 (171)	2-3/8 (60)
3 (80)	7-1/4 (184)	2-3/4 (70)
4 (100)	8 (203)	3-1/2 (89)
5 (125)	9 (229)	3-1/2 (89)
6 (150)	9-7/8 (251)	4 (102)
8 (200)	10-1/2 (267)	6-1/4 (159)
10 (250)	12-1/2 (318)	6 (152)
12 (300)	14 (356)	8-1/2 (216)

Valve is tapped so that Pilot may be mounted on either side.

TYPE ET124 / ET134 AND E2T134 TEMPERATURE AND PRESSURE REGULATOR

CAST IRON or STEEL

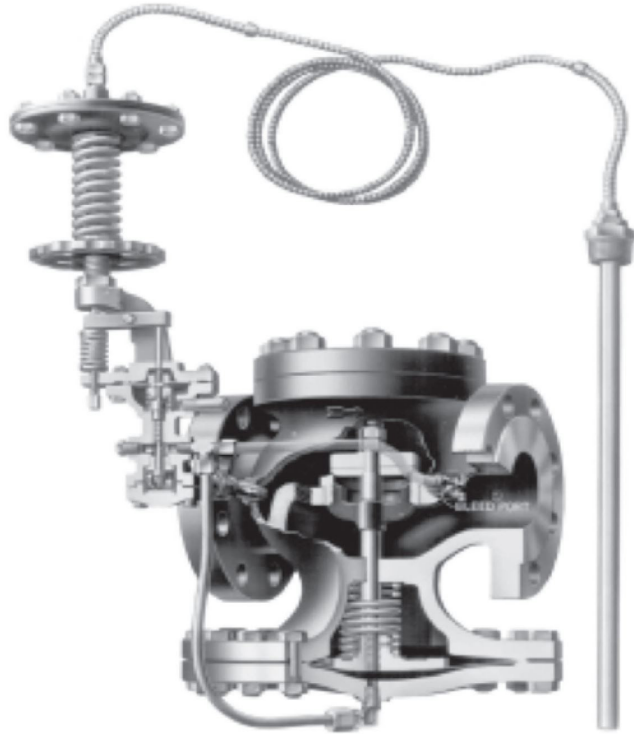

APPLICATION DATA

- Instantaneous Heaters
- Jacketed Kettles
- Storage Heaters
- Oil Heaters
- Batch Heating
- Process Heaters
- Vats
- Drivers
- Ovens

MODELS

- **ET124** for heater operating pressures between 20 and 125 psi.
- **ET134** for heater operating pressures up to 20 psi.
- **E2T134** for heater operating pressures up to 15 psi.

E VALVE INFO PAGE 22 / E2 VALVE INFO PAGE 24
PILOT INFO PAGE 52

COMBO
REGS

DIMENSIONS, in. (mm)

SIZE	F	G	
		E	E2
3/8 (10)	5-3/8 (136)	1-1/4 (32)	- --
1/2 (15)	5-3/8 (136)	1 1/4 (32)	- --
3/4 (20)	5-3/8 (143)	1-3/8 (35)	1-3/8 (35)
1 (25)	5-3/8 (146)	1-1/2 (38)	1-1/2 (38)
1 1/4 (32)	6 (152)	1-7/8 (48)	1-7/8 (48)
1 1/2 (40)	6-1/4 (159)	2 (51)	2 (51)
2 (50)	6-5/8 (168)	2-1/8 (54)	2-1/8 (54)
2-1/2 (65)	6-3/4 (171)	2-3/8 (60)	2-3/8 (60)
3 (80)	7 1/4 (184)	2-3/4 (70)	2-3/4 (70)
4 (100)	8 (203)	3-1/2 (89)	3-1/2 (89)
5 (125)	9 (229)	3-1/2 (89)	3-1/2 (89)
6 (150)	9-7/8 (251)	4 (102)	4 (102)
8 (200)	10-1/2 (267)	6-1/4 (159)	6-1/4 (159)
10 (250)	12-1/2 (318)	6 (152)	6 (152)
12 (300)	14 (356)	8-1/2 (216)	7 1/2 (216)

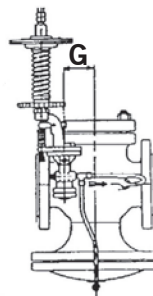
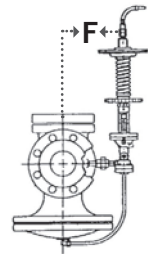

Valve is tapped so that Pilot may be mounted on either side.

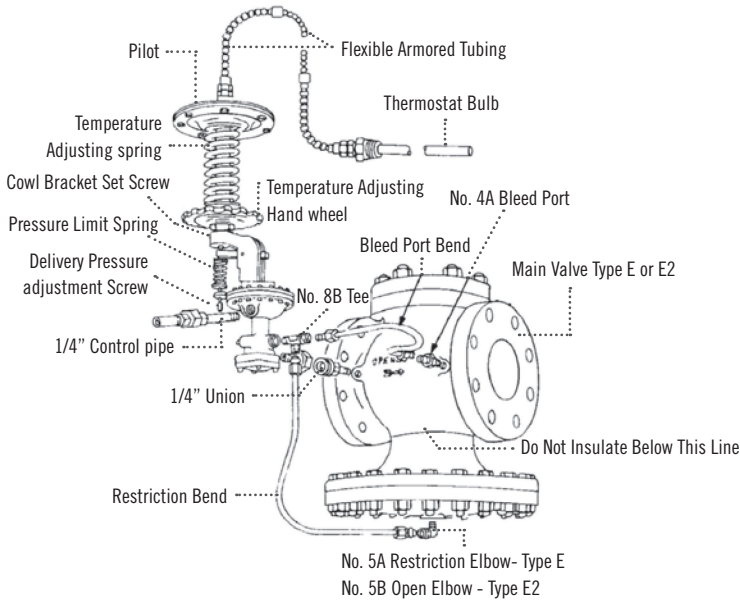

NOTES

A series of horizontal dotted lines for taking notes, spanning the width of the page.

DIRECT OPERATED VALVES

SERIES 2000 TEMPERATURE REGULATOR

PRESSURES TO 250 PSIG TEMPERATURES TO 415°F

DIRECT
OP REG



SIZING INFO PAGE 100

Stainless Steel Disc

is self aligning to assure accurate seating, long wear and tight closure.

Adjusting Key

is conveniently located and always there when settings have to be changed.

Galvanized Iron Union Ends

for sturdiness and ease of installation.

Full Ported and Full Flow Bronze Valve Body

provides maximum capacity for each valve size

Heavy Section Valve Body

is tough, solid, durable and will stand severe piping strains for pressures to 250 psig at 406°F

Positionable Temperature Indicator

(indicating regulators only) may be turned in direction of easiest reading. Highly accurate with stainless steel case and bayonet lock ring.

Over-temperature Protection

prevents damage to regulator from inadvertent overheating.

Thermal System

is heavy duty bronze bellows with bronze spiral armored copper capillary, copper bulb and epoxy coated bellows housing. Other line and bulb materials available.

Extra Long Adjustment Spring

permit Adjustment over a wide range of temperatures

Packing Assembly

with spring loaded self adjusting chevron type Teflon packing eliminates the human factor of improper adjustment.

Epoxy Coated Compact Single Piece Channel Frame

permits installation in tight locations.

Full Scale Adjustment

Makes repeat settings easy and accurate

Double Guided Stainless Steel Monolithic Disc Assembly

maintains proper alignment of all moving parts.

Stainless Steel Seat Rings

are threaded and bonded to eliminate any possibility of leakage through seat ring threads

DIRECT ACTING

- Bottle Washers
- Steam Tables
- Planting Tanks
- Heating Ducts
- Sterilizers
- Fuel Oil Heaters
- Cooking Vats
- Water Heaters
- Heat Exchangers
- Parts Washers

REVERSE ACTING

- Induction Furnaces
- Industrial Compressors
- Engine Jacket Cooling
- Cooling Ducts
- Liquid Chillers
- Fuel Oil Heaters

THREE WAY ACTING

- Fire Tube Boilers
- Internal Combustion Engine
- Coolers
- Filters

SERIES 2000 TEMPERATURE REGULATOR

SIZES 1/2" TO 2" - CONTROLS 45 TO 415°F



SERIES 2000 TEMPERATURE REGULATOR
SIZING INFO PAGE 100

APPLICATION DATA

DIRECT ACTING

- Bottle Washing Machinery
- Steam Tables
- Plating Tanks
- Heating Ducts
- Fuel Oil Heaters
- Cooking Vats
- Water Heaters
- Heat Exchangers
- Parts Washer

THREE-WAY MIXING

- Fire Tube Boiler
- Internal Combustion Engine

REVERSE ACTING

- Induction Furnaces
- Industrial Compressors
- Cold Storage Boxes
- Cooling Ducts
- Engine Jacket Cooling
- Liquid Chillers

GAS SERVICE

- Oil Treaters
- Line Heaters
- Separators
- Glycol Dehydrators
- Storage Tanks

VALVE RATINGS

Valve Ends	Pressure	Temperature
ASME/ANSI	PSIG (bar)	°F (°C)
Class 250 NPT	250 (17.2)	415 (213)

Canadian Registration# OC 0591.9C

- Self-actuated
- Two and Three Way Valve Bodies
- Single or Double Seat
- Overtemperature Protection
- Spring Loaded Teflon Chevron Type Packing Assembly
- Double Guided Stainless Steel Monolithic Disc Assembly
- Stainless Steel Seat Rings and Disc
- Adjusting Key Attached
- Full Ported and Full Flow Bronze Body
- Copper Bulb with 8' Armored Capillary

MODELS

- Type 2010 - Single Seat, Direct Acting
- Type 2020 - Single Seat, Reverse Acting
- Type 2030 - Double Seat, Direct Acting
- Type 2040 - Double Seat, Reverse Acting
- Type 2050 - Three-way Mixing and Diverting
- Type 2060 - Gas Service-15 psig maximum. If pressure exceeds 15 psi, a pressure reducing regulator should be used ahead of the temperature regulator.

OPTIONS

- Dial Temperature Gage (Indicating)
- Stainless Steel Bulb
- Stainless Steel Armored Capillary
- Capillary lengths greater than 8'
- Extra Large Bulb
- Union Bushings and Wells

DIRECT
OP REG

SERIES 2000

TEMPERATURE REGULATOR

SPECIFICATION

The valve shall be direct-operated, requiring no external energy source. It shall have single or double stainless steel seats with double guided monolithic disc assembly for proper alignment. The valve shall be direct acting (heating) or reverse acting (cooling) and have two way or three way operation. The packing assembly shall be spring loaded, self adjusting with chevron type Teflon packing. The thermal system line and bulb assembly shall be partially filled with a liquid/gas combination and in a range selected for fast response. The valve rating shall be 250 PSIG at 400°F. Body materials shall be bronze. **MODEL 2060 FOR GAS SERVICE ONLY:** The valve shall be direct-operated, requiring no external energy source and designed to control process temperature by regulating gas flow. It shall be normally open and close with increased temperature. "Bubble tight" dead end shutoff shall be provided by Buna-N vulcanized to disc backing. The packing assembly shall be spring loaded, self adjusting with chevron type Teflon packing. The thermal system line and bulb assembly shall be partially filled with a liquid/gas combination and in a range selected for fast response. The valve rating shall be 15 PSIG. Body materials shall be nodular iron.

MATERIALS OF CONSTRUCTION

ITEM	TYPE 2010-2050	TYPE 2060
Body	Bronze ASTM B62 C83600	Ductile Iron ASTM A536 65-45-12
Trim	Stainless Steel	Buna-N
Packing	Teflon	Buna-N
Unions	Iron	Iron
Yoke	Steel	Steel
Cap	Brass	Aluminum
Bellows	Bronze, Brass or Copper	Bronze
Spring	Steel	Steel
Capillary	Copper or SST	Copper
Bulb	Bronze or SST	Copper
Armor	Brass or SST	--
Stem	304 Stainless Steel	304 Stainless Steel
Disc	304 Stainless Steel	Buna-N
Seat	303 Stainless Steel	--

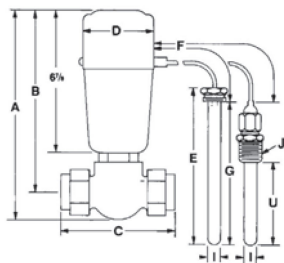

TYPE 2060 GAS SERVICE

TYPE 2060 GAS SERVICE DIMENSIONS, in. (mm) AND WEIGHTS, lbs (kg)

Valve Size, NPT	Dimensions					Shipping Weight (Approx)
	A	B	C	D	Ft	
1/2						8 (3.6)
3/4	9 3/4 (248)	8 1/2 (216)	5 5/8 (143)	3 1/2 (89)	10 Ft. (3 m.)	
1						

* See following pages for standard lengths, ranges, bulb sizes and maximum line lengths.

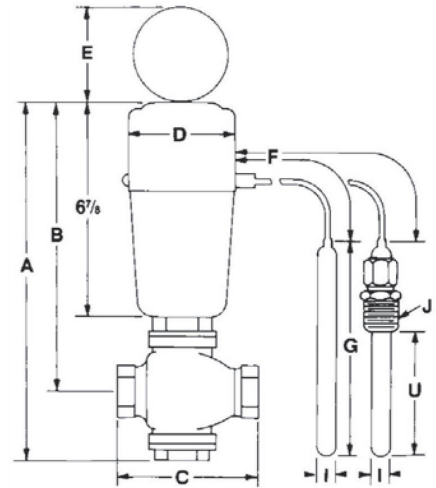

TYPE 2010-2040 DIRECT AND REVERSE ACTING

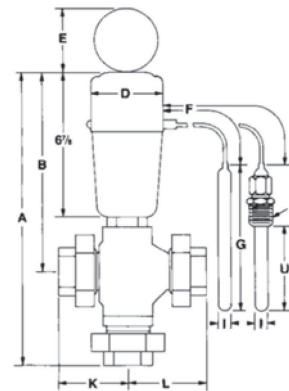

TYPE 2050 THREE WAY

TYPE 2010-2040 DIRECT AND REVERSE ACTING DIMENSIONS, in. (mm) AND WEIGHTS, lbs (kg)

Valve Size, NPT	Shipping Weight (Approx)	Type	Dimensions					Ft
			A	B	C	D	E	
1/2 (A, B, C, D, E) 1/2, 3/4	10 (4.5)	2010	9 3/4 (248)	8 1/2 (216)	5 1/2 (140)	3 1/2 (89)	2 13/16 (71)	8 Ft.
		2020						
1/2 3/4	13 (5.9)	2030 2040	12 7/16 (316)	9 3/4 (248)	7 3/16 (182)	3 1/2 (89)	2 13/16 (71)	8 Ft.
1	13 (5.9)	2010 2020 2030 2040	12 7/16 (316)	9 3/4 (248)	7 3/16 (182)	3 1/2 (89)	2 13/16 (71)	8 Ft.
1 1/4 1 1/2 2	20 (9.1) 25 (11) 30 (14)		12 7/8 (327)	9 31/32 (253)	8 15/16 (227)	3 1/2 (89)	2 13/16 (71)	8 Ft.

TYPE 2050 THREE WAY DIMENSIONS, in. (mm) AND WEIGHTS, lbs (kg)

Valve Size, NPT	Shipping Weight (Approx)	Type	Dimensions					Ft						
			A	B	Ft	D	E							
1/2 3/4 1	12 (5.5) 12 (5.5) 13 (5.9)	13 7/8 (352)	9 3/4 (248)	3 1/2 (89)	8 Ft.	3 5/16 (84)	3 5/8 (92)	2 13/16						
	27 (372)								14 21/32 (253)	9 31/32 (89)	3 1/2	8 Ft.	4 1/8 (119)	4 11/16 (71)
	33 (15)								14 7/8 (378)	9 31/32 (253)	3 1/2 (89)	8 Ft.	4 3/16 (106)	4 7/8 (124)

TYPE D50A PRESSURE REDUCING VALVE



**TYPE D50A DIRECT ACTING PRESSURE
REDUCING VALVE**

PRESSURES TO 200 PSIG AT 400°F

- Direct Acting
- Steam, Water or Air

APPLICATION DATA

- Steam Irons
- Autoclaves
- Laundry Mangles
- Single Radiators
- Steam Tables
- Vulcanizers

OPTIONS.....

- PTFE Disc for Dead-end Service for Steam
- Nitrile (NBR) Disc material for Air or Water service

Add uniflex Pipe Coupling for ease of maintenance
Consult factory for pricing and availability

DIRECT
OP REG

TYPE D50A

PRESSURE REDUCING VALVE

SPRING RANGES.....

BODY SIZE		SPRING RANGE			
		Water and Air		Steam	
in	mm	psig	bar	psig	bar
1/4	7	2 to 25	0.14 to 1.72	2 to 25	0.14 to 1.72
		20 to 60	1.38 to 4.14	20 to 60	1.38 to 4.14
		30 to 100	2.07 to 6.90	30 to 100	2.07 to 6.90
		50 to 150	3.45 to 10.3	50 to 125	3.45 to 8.62
3/8	9.5	2 to 30	0.14 to 2.07	2 to 30	0.14 to 2.07
		20 to 70	1.38 to 4.83	20 to 70	1.38 to 4.83
		40 to 110	2.76 to 7.58	40 to 110	2.76 to 7.58
		90 to 150	6.21 to 10.3	90 to 125	6.21 to 8.62
1/2	13	2 to 30	0.14 to 2.07	2 to 30	0.14 to 2.07
		10 to 50	0.69 to 3.45	10 to 50	0.69 to 3.45
		30 to 125	2.07 to 8.62	30 to 125	2.07 to 8.62
		50 to 150	3.45 to 10.3	50 to 125	3.45 to 8.62
3/4	19	2 to 20	0.14 to 1.38	2 to 20	0.14 to 1.38
		10 to 35	0.69 to 2.41	10 to 35	0.69 to 2.41
		30 to 75	2.07 to 5.17	30 to 75	2.07 to 5.17
		50 to 110	3.45 to 7.58	50 to 110	3.45 to 7.58
		105 to 150	7.24 to 10.3	105 to 125	7.24 to 8.62
1	25	2 to 20	0.14 to 1.38	2 to 20	0.14 to 1.38
		10 to 45	0.69 to 3.10	10 to 45	0.69 to 3.10
		20 to 60	1.38 to 4.14	20 to 60	1.38 to 4.14
		55 to 100	3.79 to 6.90	55 to 100	3.79 to 6.90
		90 to 150	6.21 to 10.3	90 to 125	6.21 to 8.62
1-1/4 and 1-1/2	32 and 38	2 to 15	0.14 to 1.03	2 to 15	0.14 to 1.03
		10 to 30	0.69 to 2.07	10 to 30	0.69 to 2.07
		20 to 50	1.38 to 3.45	20 to 50	1.38 to 3.45
		45 to 100	3.10 to 6.90	45 to 100	3.10 to 6.90
		90 to 150	6.21 to 10.3	90 to 125	6.21 to 8.62
2	51	2 to 20	0.14 to 1.38	2 to 20	0.14 to 1.38
		10 to 60	1.69 to 4.14	10 to 60	1.69 to 4.14
		20 to 100	1.38 to 6.90	20 to 100	1.38 to 6.90
		90 to 150	6.21 to 10.3	90 to 125	6.21 to 8.62

DIRECT
OP REG

TYPE D50A PRESSURE REDUCING VALVE

SPECIFICATION

The valve shall be direct operated, requiring no external energy source. The valve shall operate quickly and provide dead end shut off. The body materials and rating shall be cast iron for 200 psig and 400°F. Valve trim material is to be stainless steel. Valve to have a standard aspirator to allow for adjustment of operation.

MATERIALS OF CONSTRUCTION

Body	Iron
Spring	Steel
Bottom Plug.....	Brass
Seat Disk	
- Water and Air.....	Nitrile (NBR)
- Steam	Polytetrafluoroethylene (PTFE)
Diaphragm	
- Water and Air.....	Nitrile (NBR)
- Steam	Bronze

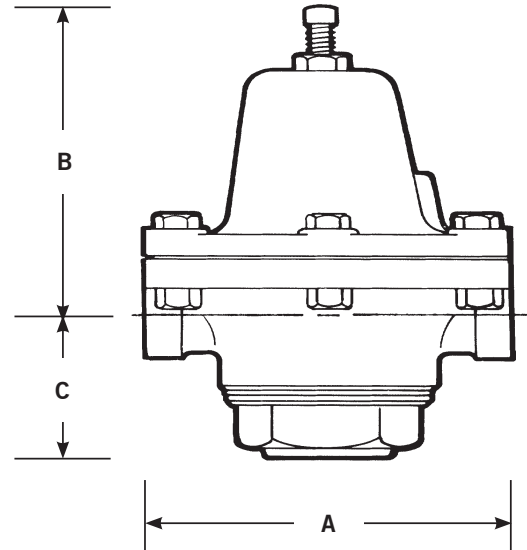

TYPE D50A DIRECT ACTING PRESSURE REDUCING VALVE

SIZING INFO PAGE 114

DIRECT
OP REG

DIMENSIONS INCHES (MM) AND WEIGHTS POUNDS (KG)

REGULATOR SIZE, NPT	DIMENSION						SHIPPING WEIGHT	
	A		B		C		Iron	
	In.	mm	In.	mm	In.	mm	lbs	kg
1/4	3.06	77.7	2.429	73.0	1.869	44.5	2-3/4	1
3/8	3.88	98.5	2.554	114	1.742	44.5	5	2
1/2	4.47	113.5	2.953	114	2.078	54.0	7-1/2	3
3/4	5.09	129.2	2.953	117	1.953	54.0	9	4
1	5.86	148.8	3.345	137	2.22	54.0	12	5
1-1/4	6.31	160.2	4.22	156	2.595	66.7	18	8
1-1/2	6.31	160.2	4.22	156	2.595	66.7	18	8
2	9.19	233.4	5.587	216	3.461	88.9	32	15

TYPE N6 DIFFERENTIAL PRESSURE VALVE



**TYPE N6 DIFFERENTIAL
PRESSURE VALVE**

SIZES 3/4" - 2 1/2" PRESSURES to 250 PSIG at 350°F

- Maintains Constant Differential Pressure
- Stainless Steel Valve Trim
- High Temperature Sealing Ring
- Polished Stainless Steel Piston
- ANSI/FCI 70-3 Class IV Shutoff

APPLICATION DATA

- Maintain Pump Discharge Pressure
- Pump Bypass Valve
- Boiler Feedwater Valve

RATED FLOW COEFFICIENTS (CV).....

VALVE SIZE					
3/4	1	1 1/4	1 1/2	2	2-1/2
7.1	13.3	22.0	32.5	51.0	88.0

SPRING RANGES (Differential Pressure, psi)

5-50 100-200
40-125

VALVE RATINGS.....

Valve Ends	Pressure	Temperature
ASME/ANSI	PSIG (bar)	°F (°C)
NPT or BSPT	250 (17.2)	@ 350 (176.7)
CL250 RF Flanged	250 (17.2)	@ 350 (176.7)

Canadian Registration# OC 0591.9C

DIRECT
OP REG

TYPE N6 DIFFERENTIAL PRESSURE VALVE

SPECIFICATIONS

Valve to maintain pump discharge pressure at a constant differential, above a separate source of pressure. Valve to be suitable for 250 psig and 350°F. Body to be of cast iron. Trim to be stainless steel. Spring to be enclosed to prevent contamination. Adjusting screw shall be protected by cap and to be easily accessible. Piston and disc to be balanced construction.

MATERIALS OF CONSTRUCTION

Body, Cast Iron.....ASTM A126 C.B
 Stem303 St. Stl. ASTM 582 Cond. A
 Disc420 St. Stl. ASTM 276 Cond.A
 Seat Ring.....420 St. Stl. ASTM 276 Cond.A
 Piston.....303 St. Stl. ASTM 582 Cond.A
 Sealing RingViton
 Gasket Graphite
 Spring St. Stl. 17- 4

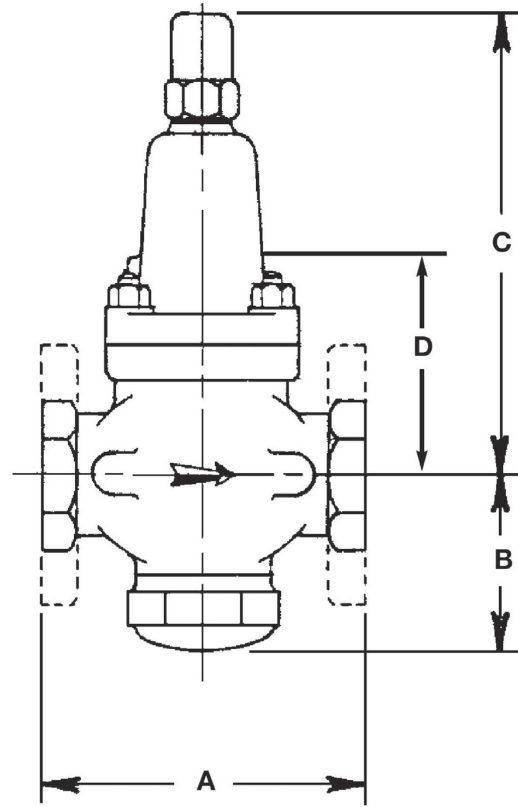

DIRECT
OP REG

DIMENSIONS inches (mm) AND WEIGHTS pounds (kg)

SIZE	A		B	C	D	APPROX. WT.	
	ANSI NPT	ANSI 250				ANSI NPT	ANSI 250
3/4 (19)	4 3/4 (121)	-- --	2-3/4 (70)	7 1/2 (190)	3 (76)	10 (4.5)	-- --
1 (25)	5 3/8 (137)	-- --	3 (76)	8-1/2 (216)	3 5/8 (92)	12 (5.5)	-- --
1 1/4 (32)	6 1/2 (165)	-- --	3 5/8 (92)	9 3/8 (238)	3 7/8 (98)	19 (8.6)	-- --
1 1/2 (38)	7-1/4 (184)	-- --	3 3/4 (95)	10 7/8 (276)	4 1/4 (108)	26 (12)	-- --
2 (51)	7 1/2 (191)	-- --	4 3/8 (111)	11 7/8 (302)	4 7/8 (124)	39 (18)	-- --
2-1/2 (64)	-- --	10 (254)	4 1/2 (114)	14 3/8 (365)	5-3/8 (136)	-- --	74 (34)

TYPE D AND D2 PRESSURE REDUCING VALVE

SIZES 1/4" - 1/2"
PRESSURES TO 600 PSIG AT 750°F

- Self-contained
- Direct Operated
- Normally Open
- Packless Construction
- Accurate Regulation Unaffected by Service Conditions
- Easy In-line Maintenance
- Five Spring Ranges for Improved Control
- Utilizes Many Standard D/D2 Pilot Components

MODELS

- **TYPE D VALVE** for ± 1 PSI control of delivery pressure between 3 and 150 PSI
- **TYPE D2 VALVE** for ± 2 PSI control of delivery pressure between 100 and 300 PS

OPTIONS

- Enclosed Spring Chamber
- Adjusting Handwheel
- Composition Disc
- Locking Device
- Wall Bracket

TYPICAL CONFIGURATIONS

PRESSURE REDUCING.....TYPED VALVE

PRESSURE REDUCINGTYPE D2 VALVE

APPLICATION DATA

- Pressure Regulating for Steam Distribution
- Regulating for Fluid, Gas and Vapor Process Control
- Processes with Small, Relatively Steady Flow Rates

SPRING PRESSURE RANGES (PSIG)

Construction	Pressure	Temperature
	PSIG (bar)	°F (°C)
Cast Iron	250 (17.2)	@ 400 (204)
Cast Steel	600 (41.4)	@ 750 (400)



SPRING PRESSURE RANGES (PSIG)

TYPE D	TYPE D2
3-20	100-300
5-50	
10-100	
20-150	

TYPE D AND D2 PRESSURE REDUCING VALVE

SPECIFICATIONS

The Valve shall be of normally open design with packless construction. A strainer Screen shall be built into the valve inlet. The valve shall be single-seated, spring loaded and diaphragm actuated.

MATERIALS OF CONSTRUCTION

Body, Cast Iron	ASTM A126 CI B
Body, Cast Steel	ASTM A216 GR. WCB
Stem.....	303 St. Stl. ASTM A582 COND A
Disc.....	440 St. St. ASTM A276-75 COND A
Seat.....	420 St. Stl. ASTM A276 COND A
Gasket	Graphite
Diaphragm.....	301 St. Stl. MIL-5-5059C
Spring.....	Inconel

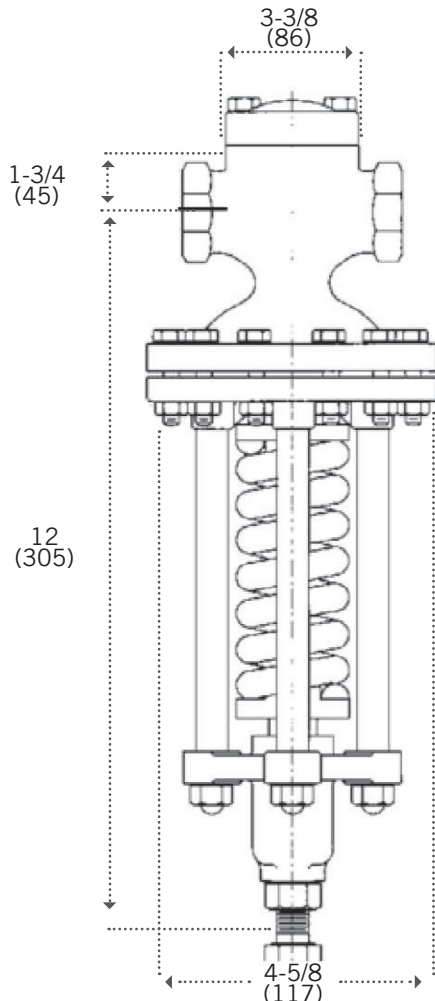

D2 VALVE 10.6 LBS. (4.8 KG)

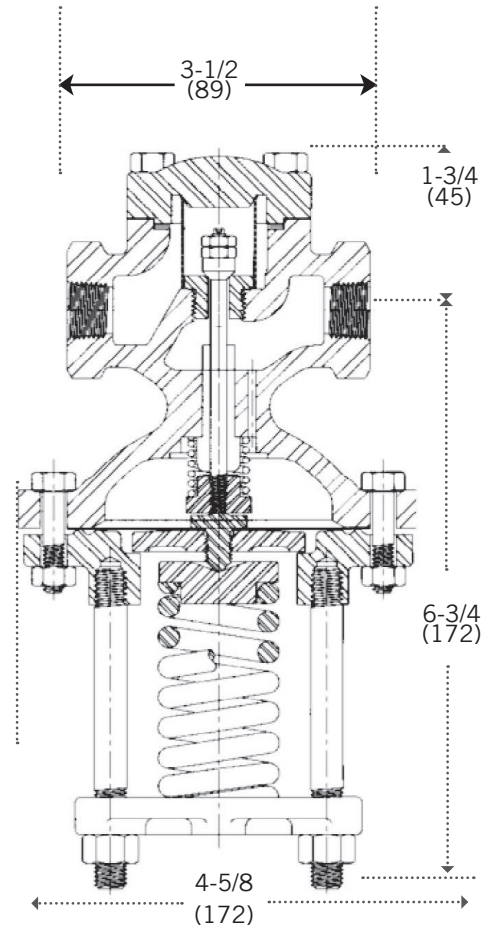

**D VALVE
7.3 LBS. (3.3 KG)**

DIRECT
OP REG

TYPE D34

WATER PRESSURE REDUCING VALVE

SIZES 1" - 6"
PRESSURES TO 200 PSIG AT 200°F

- Self-contained
- Closes Tight on Dead-end Shutoff
- Fast Acting for Rapid Changes in Flow
- Sediment Settles away from Control Ports when Installed Horizontally
- ANSI/FCI 70-3 Class VI Shutoff

APPLICATION DATA

- Dead-end water service where flow is intermittent and changes rapidly
- Flushometers
- snap cocks



TYPE D34 WATER PRESSURE REDUCING VALVE

VALVE RATINGS

Valve Ends	Pressure	Temperature
ASME/ANSI	PSIG (bar)	°F (°C)

CAST IRON

NPT Threaded	200 (13.8)	@	200 (93)
CL125 FF Flanged	165 (11.4)	@	200 (93)
CL250 RF Flanged	200 (13.8)	@	200 (93)

SPRING RANGES (PSI)

10-40	30-80	70-140
-------	-------	--------

Canadian Registration# OC 0591.9C

RATED FLOW COEFFICIENTS (CV)

	VALVE SIZE								
	1	1 1/4	1 1/2	2	2-1/2	3	4	5	6
Cv	5.5	12.5	17.3	24	36	53	86	139	196

TYPE D34

WATER PRESSURE REDUCING VALVE

SPECIFICATIONS

The Valve shall be adjustable, direct operated, packless, diaphragm actuated, balanced and single seated. The valve shall close tight on dead end shutoff and shall maintain a discharge pressure which will not vary more than 1 psig for each 10 psig inlet pressure variation. Delivery pressure variations from zero flow to rated flow shall not exceed 15% of the maximum spring pressure rating. The valve shall be suitable for 200°F service temperature.

Valve body shall be cast iron. Sizes 2-1/2" and larger shall have flanged ends. Trim shall be stainless steel. Valve shall be equipped with a reversible composition disc and diaphragms and discs shall be Nitrile. All working parts shall be easily accessible without removal of valve from the line.

MATERIALS OF CONSTRUCTION

Body, Cast SteelCast Iron ASTM A125 Cl. B
 Stem 303 St. Stl. ASTM 582 Cond. A
 Disc..... Nitrile
 Seat.....304 St. Stl. ASTM 276 Cond. A
 Gasket Graphite
 Diaphragm..... Nitrile
 Spring Steel

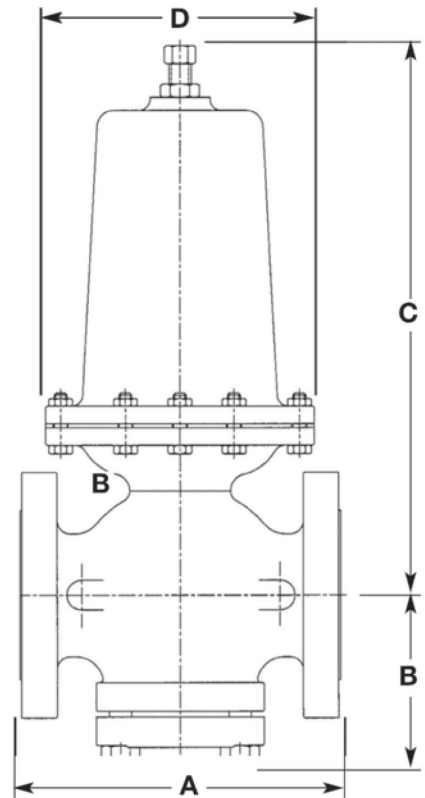

TYPE D34
WATER PRESSURE REDUCING VALVE

DIRECT
OP REG

DIMENSIONS inches (mm) AND WEIGHTS Pounds (kg)

SIZE	FACE TO FACE			OTHER DIMENSIONS			APPROX. WT		
	A			B	C	D	ANSI NPT	ANSI 125	ANSI 250
	ANSI NPT	ANSI 125	ANSI 250						
1 (25)	5-3/8 (136)	-	-	3-3/8 (86)	12-1/8 (308)	5-1/2 (140)	22 (10)	-	-
1-1/4 (32)	6-1/2 (165)	-	-	3-5/8 (92)	12-1/2 (316)	5-1/2 (140)	24 (11)	-	-
1 1/2 (38)	7-1/4 (184)	-	-	4-1/4 (108)	13-3/8 (340)	6 (152)	34 (15)	-	-
2 (51)	7-1/2 (191)	8-1/2 (216)	9 (228)	4-5/8 (117)	14-3/4 (375)	6-3/4 (171)	44 (20)	51 (23)	57 (26)
2-1/2 (64)	-	9 3/8 (238)	10 (254)	5-1/2 (140)	18-3/4 (476)	8 (203)	-	78 (35)	89 (40)
3 (76)	-	10 (254)	10-3/4 (273)	6 (152)	21-3/4 (552)	9 (229)	-	108 (49)	128 (58)
4 (102)	-	11-7/8 (302)	12-1/2 (318)	6-5/8 (168)	26-5/8 (676)	11-1/4 (283)	-	198 (90)	225 (102)
5 (127)	-	13-5/8 (346)	14-1/2 (268)	7-5/8 (194)	33-1/8 (841)	14-1/4 (362)	-	352 (160)	394 (252)
6 (152)	-	15-1/8 (384)	16 (406)	9-1/8 (232)	35-7/8 (911)	16 (406)	-	500 (227)	550 (250)

REGULATOR SIZING

DEFINITIONS RELATING TO REGULATOR CAPACITY

The capacities contained in this bulletin are based on a specific level of performance by the regulator. The measure of performance is accuracy of regulation, also known as offset or deviation. Each table is appended with a footnote indicating the accuracy of regulation obtainable at the rated capacities listed.

Pertinent terms involved in the determination of accuracy of regulation and rated capacity are defined as follows:

- **CONTROLLED VARIABLE** is the variable which shall be monitored by the controlling process. This variable is either the outlet pressure or the differential pressure.
- **MINIMUM CONTROLLED FLOW** is the lowest flow rate, at a given set point and temperature, at which a steady regulated condition of the controlled variable can be maintained. For some regulators, minimum controllable flow is essentially zero. It is used to determine turndown or rangeability.
- **SET POINT** is the regulator adjustment corresponding to the desired value of the controlled variable.

- **RATED CAPACITY** is the rate of flow obtainable through a regulator, for specified inlet and outlet conditions and fluid, as a specified offset or accuracy of regulation.

- **ACCURACY OF REGULATION** is the deviation from the set point, expressed as a percentage or as a fixed unit, taken at the test conditions.

- **LOCK-UP** or dead-end shutoff, is the deviation of the controlled variable from set point obtained at a no-flow condition.

- **Adapted** from "PRESSURE REDUCING REGULATOR CAPACITY" Standard No. ANSI/FCI 99-2, published by Fluid Controls Institute, Inc.

TYPICAL REGULATION CURVE

The performance characteristic of a Spence Pressure Regulator is shown above. Using this curve to illustrate several terms of reference, the following facts are evident:

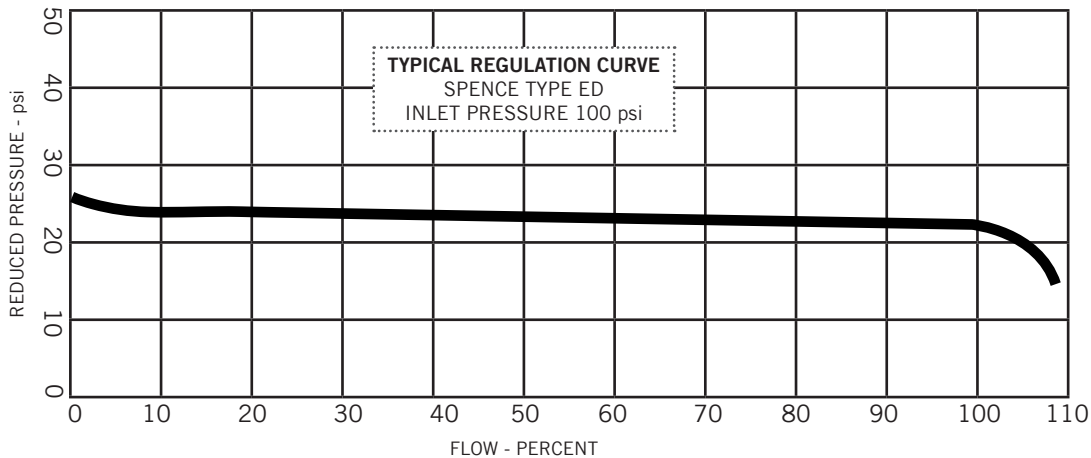

REGULATED VARIABLE	REDUCED PRESSURE
Minimum Controlled Flow	4%
Set Point	25.0
Reduced Pressure at Rated (100%) Flow	22.5 psi
Accuracy of Regulation, psi	2.5 psi
Accuracy of Regulation, % of set pressure	10%

The slight slope of the curve establishes a definite relationship between flow and regulated pressure. Note that 1 psi accuracy of regulation is obtainable at 95% of rated flow.

For back pressure regulation, or differential where the regulator opens on increasing differential, the characteristic curve would lie opposite to that shown. It would slope upward with flow increase because a positive deviation is required to cancel valve opening.

NOTES ON USE OF TABLES

The lowest reduced pressures are approximate critical pressures. No appreciable increase in flow can be obtained at lower pressures.

Downstream pipe size should be enlarged at regulator outlet to approximately equalize pipe velocities before and after the reduction. The Steam Capacity Tables are useful for determining steam pipe sizes and regulator size at any desired lower velocity level.

Reduced Seats—Spence Regulators are available with a choice of seat sizes called Full and Normal Ports. There is a capacity table for each port with standard plugs. The Cv Valve Coefficients shown on the back page, indicate where 75% and 50% parabolic plugs are available. For a given pressure drop, rated flows with various ports and plugs in the same size body may be compared. Thus, valve and port size may be selected to limit velocities entering and leaving the regulator. Lower velocities mean a greater proportion of the pressure drop occurs at the valve seat, where it belongs, rather than in the body outlet and connected piping.

Capacity ratings apply to Spence Regulators with Type D, N and Q Pilots which are spring loaded and have 3^{1/2} inch diaphragms. Other pilots having greater or lesser sensitivity will provide proportionally greater or less accuracy of regulation.

PLANNING MAIN VALVE INSTALLATION

A. PLANNING THE INSTALLATION

1. Locate the valve in a straight run of horizontal pipe. See Fig 1.
2. Allow headroom above the valve for access through the blind flange. Provide clearance for stem withdrawal underneath.
3. Prevent water hammer and erratic operation by installing traps to provide proper drainage before and after the valve, and before secondary PRV or control valve.
4. Avoid damaging affects of scale and did in pipe lines by using a strainer as shown in Fig. 1 .
5. Provide a 3-valve by-pass to facilitate inspection without interrupting service.
6. To eliminate excessive noise and erratic regulation with steam and other compressible fluids enlarge the delivery pipe size to effect a reasonable flow velocity at the reduced pressure. A tapered transition is recommended. If possible, avoid a sharp turn close to the regulator outlet and a bull-headed tee connection to the low pressure main.
7. Install initial and delivery pressure gauges to indicate performance. If the pressure rating of the delivery system or connected equipment is less than the initial steam pressure, provide a safety valve.

B. CONTROL PIPE

1. Use 1/4" pipe for this line which connects the pilot diaphragm chamber to the desired point of pressure control. See Fig. 1.
2. Take the control at a point of minimum turbulence. Avoid control immediately at the valve outlet or after a turn. When the delivery pipe expands in size select a spot at least 4 pipe diameters beyond the point of enlargement.
3. Pitch away from pilot to avoid erratic operation and fouling. Eliminate water pockets.
4. Locate delivery pressure gauge in control pipe to show. pressure actually reaching pilot diaphragm.

- | | |
|--------------------|------------------------|
| 1. Inlet Pipe | 8. SRV Type |
| 2. Isolation Valve | 9. Drip Pan Elbow |
| 3. Strainer | 10. Vent Stack |
| 4. PRV Type | 11. Low Pressure Trap |
| 5. Bypass Pipe | 12. High Pressure Trap |
| 6. Bypass Valve | |
| 7. Delivery Pipe | |

Provide as much straight run of pipe on both sides of regulator as possible:

- 10 pipe diameters minimum to the inlet.
- 20 pipe diameters minimum of expanded line size from the outlet.

C. DESIGN GUIDELINES TO MINIMIZE NOISE

1. Size the regulator to provide a maximum inlet velocity of about 10,000 FPM.
2. Determine the regulator outlet velocity. if it would exceed 30,000 FPM, use a Spence muffling orifice or a second stage regulator.
3. Expand regulator outlet piping to limit discharge line velocity to about 10,000 FPM.
4. Avoid abrupt changes in pipe size. Limit pipe diameter changes to two pipe sizes per stage of expansion. Do not use eccentric reducers.
5. Directional changes in downstream piping should be made only after the line size has been increased. Use long radius fittings; avoid bull-head tee connection.
6. Provide as much straight run of pipe on both sides of regulator as possible:
 - a - 10 pipe diameters minimum to the inlet.
 - b - 20 pipe diameters minimum of expanded line size from the outlet.
7. Size all piping components, including strainer and stop valves for a maximum flow velocity of about 10,000 FPM (Exception: An outlet stop valve mounted at the regulator outlet should be equal in size to the regulator). In areas where low sound levels are specified, reduce this limit by 25% to 50%.
8. To limit noise transmission through the building's structure. keep the regulator and piping at least 3 feet away from solid surfaces. Use sound-isolating piping supports.
9. Apply high density insulation to the regulator body, piping and system components. Insulation reduces heat loss significantly and can provide moderate (3-6 dB) local noise attenuation.
10. Use a Spence noise suppressor to reduce the propagation of noise via the downstream piping

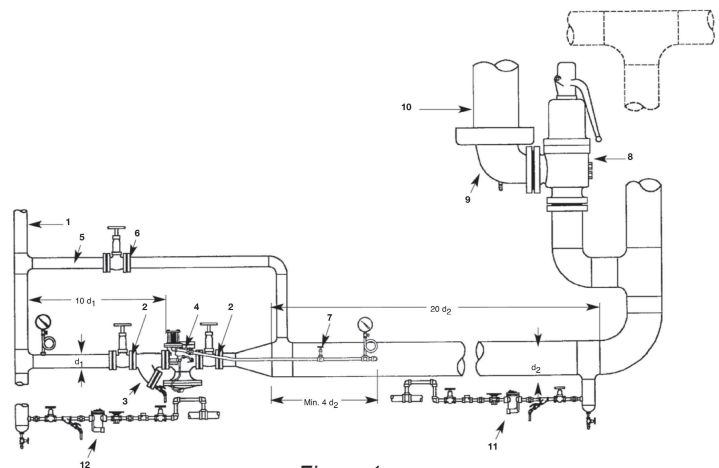

Figure 1

MAIN VALVE SELECTION

When you select a Main Valve, your sizing can be based on one of three methods. They are:

ECONOMICAL MAIN VALVE Economical Main Valve Selection is choosing a regulator that has the line size and rough capacity to handle the load. No consideration is given to velocities or noise. If you are interested in an economical selection, select a regulator type for your application, then go to the Capacity Tables and select the size that will provide you with the capacity needed.

ENGINEERED MAIN VALVE Engineered Main Valve Selection takes into consideration the inlet and outlet velocities of the regulator, It will limit these velocities to acceptable standards. See Pressure Reducing Station Design Guidelines on the following pages for details. If you are interested in an engineered selection, select a regulator

type for your application, and then to the Capacity Tables and select the size that will provide you with the capacity needed. Verify that the velocities fall within the guidelines by consulting the Velocity Charts in this Section.

ENGINEERED MAIN VALVE WITH NOISE SUPPRESSION Engineered Main Valve Selection with Noise Suppression considers both velocity and noise suppression in the selection of the regulator. For this selection, it is recommended that you contact your local Spence Technical Sales Representative who can provide you with a computer generated solution.

SELECTING A REGULATOR TYPE The following rules should be used to help you to determine the type of regulator that you should use. You should consult the Product Pages, Velocity Tables and Capacity Tables for additional information on your selection.

RULES FOR MAIN VALVE SELECTION—STEAM SERVICE

Together with the following rules, reference should be made to the Main Valve Specification Table or individual Product Pages for maximum initial pressures and temperatures and “minimum differentials” for the several types of Main Valve. For pressure reduction where fast response time is important, but capacity and accuracy are not critical, select **D50A DIRECT OPERATED REGULATOR**.

EITHER DEAD-END OR CONTINUOUS FLOW SERVICE

RULE 1. For Initial Pressures exceeding 15 psi:

(a) TYPE E - Select when the Delivery Pressure is less than 75% of Initial Pressure. For Differential Pressures of 15-50 psi, specify optional LP Spring (10 psi minimum Differential

Pressure is attainable by adding optional fittings).

(b) TYPE E5 - Select when the Delivery Pressure is 75% to 96% of Initial Pressure.

RULE 2. For Initial Pressures less than 15 psi:

(a) TYPE E2 - Select when Initial Pressure is less than 15 psi.

RULES FOR MAIN VALVE SELECTION AIR SERVICE

Together with the following rules, reference should be made to the Main Valve Specification Table or individual Product Pages for maximum initial pressures and temperatures and “minimum differentials” for the several types of Main Valve. For pressure reduction where fast response time is important, but capacity and accuracy are not critical, select **D50A DIRECT OPERATED REGULATOR**.

EITHER DEAD-END OR CONTINUOUS FLOW SERVICE

RULE 1. For Initial Pressures exceeding 15 psi:

(a) TYPE E - Select when the Delivery Pressure is less than 75% of Initial Pressure. For Differential Pressures of 15-50 psi, specify optional LP Spring (10 psi minimum Differential Pressure is attainable by adding optional fittings).

(b) TYPE E5 Select when the Delivery Pressure is 93% to 96% of Initial Pressure.

RULE 2. For Initial Pressures less than 15 psi:

(a) TYPE E2 Select when Initial Pressure is less than 15 psi.

RULES FOR MAIN VALVE SELECTION - WATER SERVICE

Pilot Operated Regulators are not uniformly successful in liquid pressure reducing service unless the delivery system has unusual cushioning such as afforded by an elevated tank or large air chamber.

WATER PRESSURE REDUCING VALVES

The TYPE D34 DIRECT OPERATED VALVE was developed for application on rapidly changing and intermittent flow to an inflexible system.

RULE 1. Select TYPE D34 DIRECT OPERATED VALVE for pressure reducing service.

FOR PILOT OPERATED WATER REGULATORS When a pilot operated regulator is required the following rules for the selection of a main valve govern:

RULE 2. When pressure drop across valve is between 5 and 10 psi:

(a) TYPE E5 Select for pressure drops not less than 5 psi.

Together with the above rules, reference should be made to the Main Valve Specification Table for maximum initial pressures and temperatures and “minimum differentials” for the several types of Main Valves.

VALVE SIZING BY COMPUTATION

FORMULA KEY

A	= Area of Pipe in (inches) ²	ΔPs	= P1 - Pv when P2 > Pv
C _v	= Valve Coefficient	ΔPs	= P1 - (.96 - .28√ $\frac{Pv}{Pc}$)Pv when P2 < Pv
EDR	= Equivalent Direct Radiation (Sq. Ft.)	q	= Liquid Flow Rate, U.S. gpm
F	= Pipe Area Factor (see Pipe Factors Table)	Q	= Flow Rate, SCFH
ft	= Feet	T	= Absolute T (T + 460)°R
G	= Specific Gravity	T _{SH}	= Steam Superheat (°F) =
ΔP	= Pressure Drop, P1 - P2 psi		Total Steam Temp. - Saturated Steam Temp.
P1	= Inlet Pressure, psia (psi + 14.7)	\bar{v}	= Specific Volume Fi-3/#
P2	= Reduced Pressure, psia (psi + 14.7)	V	= Velocity, FPM
PC	= Pressure at Thermodynamic Critical Point, psia (water = 3206 psia)	W	= Steam Flow, #/Hr.
Pv	= Vapor Pressure, psia	Ws	= Flow, #/Hr. Superheated Steam

To avoid interpolation or solve problems beyond the scope of the table, valve sizes may be determined by calculation as follows:

	C _v	
	SUBCRITICAL	CRITICAL
SATURATED STEAM:	$C_v = \frac{w}{2.1 \sqrt{\Delta P (P_1 + P_2)}} \quad P_2 > .58P_1$	$C_v = \frac{w}{1.71P_1} \quad P_2 \leq .58P_1$
SUPERHEATED STEAM:	$C_v = \frac{W (1 + .0007T_{sh})}{2.1 \sqrt{\Delta P (P_1 + P_2)}} \quad P_2 > .55P_1$	$C_v = \frac{w (1 + .0007T_{sh})}{1.75P_1} \quad P_2 \leq .55P_1$
GAS:	$C_v = \frac{Q}{963} \frac{P_2 > .5P_1}{\sqrt{\Delta P (P_1 + P_2)}} \frac{GT}{GT}$	$C_v = \frac{P_2 \leq .5P_1}{\frac{Q \sqrt{GT}}{834 P_1}}$
LIQUID:	$C_v = \frac{P_2 > .P_1 - .85 \Delta PS}{q \sqrt{\frac{G}{\Delta P}}}$	$C_v = \frac{P_2 \leq .P_1 - .85 \Delta PS}{.93q \sqrt{\frac{G}{\Delta PS}}}$

	LOADS
WATER	$W = \frac{GPM}{2} \times \text{Temp. Rise (°F)}$
FUEL OIL	$W = \frac{GPM}{4} \times \text{Temp. Rise (°F)}$
AIR	$W = \frac{CFM}{900} \times \text{Temp. Rise (°F)}$
RADIATION	$W = \frac{f^2 EDR}{4}$
ABSORPTION	$W = 16-20 \text{ #/Hr./Ton-Hr.}$
STM.ATOM	$W = 0.1 \text{ #/Hr./#Oil}$

FLOW	
STEAM	$W = \frac{.0433 \times V \times F}{\bar{v}}$
AIR and GASES	$Q = \frac{.0259 \times V \times F \times P_1}{T}$
LIQUIDS	$q = .0054 \times V \times F$

VELOCITY	
STEAM	$V = 2.4 - A$

PIPE FACTORS FOR STANDARD (SCHEDULE 40) PIPE			
SIZE	FACTOR	SIZE	FACTOR
1/8	.55	3 1/2	95
1/4	1.0	4	122
3/8	1.8	5	192
1/2	2.9	6	278
3/4	5.1	8	481
1	8.3	10	758
1 1/4	14	12	1076
1 1/2	20	14	1301
2	32	16	1699
2-1/2	46	18	2151
3	71	20	2673

REG SIZING

PRESSURE REDUCING STATION DESIGN GUIDELINES

1. SINGLE STAGE PRESSURE REGULATOR

1. When to use single stage regulator:
 - A. When load turndown requirement is generally no greater than 10:1.
 - B. When ratio of specific volume of steam, outlet to inlet, is no greater than 3 to 1.
 - C. When only one reduced steam pressure level is required.

II. PARALLEL PRESSURE REGULATORS

1. When to use parallel pressure regulator stations:
 - A. When maximum specified capacity requires selection of a pressure regulator greater than 12 inch pipe size. (It may be more economical to install two smaller valves than one very large one.)
 - B. When normal conditions require operation at 10% or less of specified maximum capacity for sustained periods.
 - C. When there are two distinct load requirements; i.e., summer winter operation
2. When to use a pneumatically operated parallel pressure valve station:
 - A. When the combined accuracy of regulation of mechanically operated controls is unacceptable.

For Spence mechanically operated regulators normal sizing selection results in accuracy of regulation of approximately 5% of set pressure. Combined accuracy of regulation of mechanically operated parallel installed regulators is approximately 10% of set pressure.

Pneumatically operated valves equipped with reset maintain set point within 1% for all sustained flows.

III. TWO STAGE PRESSURE REGULATORS'

1. When to use two stage pressure regulator stations:

† Primary PRV requires optional base bypass and 1/8" bleed port

- A. When intermediate steam pressure is required.
- B. When concerned with PRV generated noise, use two stage station when specific volume ratio, outlet to inlet, is greater than 3 to 1, unless manufacturer offers assurance or other means of meeting noise specification.
- C. When complying with Power Piping Code ANSI B31.1-1986, which reads, in part, "in district heating and steam distribution systems where the steam pressure does not exceed 400 psi (2758 kPa) and where the use of relief valves and vent piping are not feasible, two or more pressure reducing valves may be installed in series, each set at or below the safe working pressure of equipment served and no relief valve is required."

IV. TWO STAGE

PARALLEL PRESSURE REGULATORS†

1. Whenever any condition from II and any condition from III applies.

SPACE CONSIDERATIONS FOR REDUCING STATIONS

1. Following are rules of thumb for approximating spacing for installing reducing stations:
 - A. Single stage (with or without noise suppressors) Inlet side: ten (10) diameters of PRV pipe size Outlet side: twenty (20) diameters of final pipe size, where final pipe size is determined on the basis of 10,000 fpm line velocity.
 - B. Two stage Inlet side of primary: ten (10) diameters of PRV pipe size. Intermediate: twenty (20) diameters of secondary PRV pipe size, or equivalent volume. Outlet side: twenty (20) diameters of final pipe size, where final pipe size is determined on the basis of 10,000 fpm line velocity.
 - C. Two stage with muffling orifice; same as A above.

PRESSURE REDUCING STATION GENERAL SPECIFICATION

- A. Pressure Reducing Station should consist of:
 - pressure regulator
 - inlet strainer
 - inlet and outlet stop valves (gate type)
 - by-pass valve (globe type)
 - stop valve (gate type)
 - trap at inlet to pressure regulator
 - pressure gauges on inlet and outlet of station
 - pressure relief valve downstream of regulator
- B. Stop valves and strainer should be sized based on velocity
- C. Expand pressure regulator outlet pipe size to obtain discharge line velocity which will not exceed:

Up to and including 2"	15,000 FPM
2-1/2" up to 8"	10,000 FPM
Above 8"	8,000 FPM

Regulator outlet velocity exceeding 30,000 FPM a second PRV should be considered
- D. Unions shall be used on either side of screwed end by-pass valve and pressure regulator to facilitate removal.
- E. Pressure regulators 2-1/2" and larger shall have flanged ends and be suitable for pressure and temperature specified.
- F. Limit pressure regulator inlet velocity to:

Up to and including 2"	15,000 FPM
2-1/2" thru 8"	10,000 FPM
Above 8"	8,000 FPM
- G. Regulator sound pressure level while operating at specified maximum capacity shall not exceed 90 dbA as measured at a point three feet downstream and three feet from uninsulated pipe surface.
- H. Pressure regulator capacity shall not be greater than 120 of specified maximum capacity.
- I. For details of safety valve sizing and installation, please refer to the latest National Board Inspection Code and ANSI B31.1 Code.

REGULATOR CV DATA

Valve Size	E						E2 -FULL	E5		D	D34	D50A	N6	Series 2000
	NORMAL 50%	NORMAL 50%	NORMAL	FULL 50%	FULL 70%	FULL		NORMAL	FULL					
1/4	-	-	-	-	-	-	-	-	-	.25	-	-	-	-
3/8	-	-	.66	-	-	1.5	-	-	-	.32	-	-	-	-
1/2	-	-	1.55	1.7	2.2	2.8	-	-	-	.32	-	2.2	-	.4-5.22
3/4	-	-	4.8	2.6	4.2	5.4	7.6	5.7	7.6	-	-	3.3	7.1	6.85
1	-	-	7.5	6.3	7.2	8.8	11.7	10.0	11.7	-	5.5	4.9	13.3	9.15
1 1/4	-	-	10.4	7.4	11.1	14.1	18.9	13.4	18.9	-	12.5	5.0	22	14.3
1 1/2	-	-	14.6	11.3	15.9	19.8	27.4	19.8	27.4	-	17.3	10.1	32.5	15.1
2	-	-	17.6	17.7	22.9	31	44	25	43	-	24	10.8	51	17.2
2 1/2	14	18	24	25	27	44	68	35	67	-	36	-	88	-
3	26	34	43	42	56	74	96	59	95	-	53	-	-	-
4	46	62	78	65	88	109	143	120	159	-	86	-	-	-
5	65	89	115	94	136	169	202	176	258	-	139	-	-	-
6	83	110	151	139	188	248	255	228	350	-	196	-	-	-
8	139	187	249	252	353	444	462	366	665	-	-	-	-	-
10	230	294	377	400	558	706	748	525	1018	-	-	-	-	-
12	363	463	631	631	880	1113	1118	952	1611	-	-	-	-	-

75% AND 50% REDUCED TRIM (Parabolic)

The Parabolic Discs given in the above table are designed to:

- Improve performance at minimum flows by improving stability over wide flow ranges.
- Provide easy field conversion to obtain a substantial increase or decrease in regulator Cv to meet system load requirements.
- Facilitate selection of smaller size safety relief valves.
- Size more precisely to the required Cv, thereby eliminating one of the most frequent causes of poor performance.

SATURATED STEAM FLOW TABLE (LB/HR) BASED ON SCHEDULE 40 PIPE

SIZES 1/4" THROUGH 2"

VEL., FPM	45000	45000	45000	45000	45000	45000	45000	45000
PRESS. (PSIG)	REGULATOR or PIPE SIZE (inches)							
	1/4	3/8	1/2	3/4	1	1 1/4	1 1/2	2
-10	23	43	68	120	195	337	458	755
-5	51	93	148	260	422	730	994	1638
0	73	134	213	373	605	1046	1424	2348
5	97	178	284	498	807	1396	1900	3132
10	120	220	350	613	994	1720	2342	3860
15	142	260	415	728	1179	2041	2778	4579
20	164	301	479	841	1363	2359	3210	5292
25	186	341	543	953	1545	2673	3639	5998
30	208	381	607	1065	1726	2987	4065	6700
40	251	460	732	1285	2083	3605	4906	8087
50	293	538	857	1504	2437	4217	5740	9461
60	336	616	981	1721	2789	4827	6570	10829
70	377	692	1102	1934	3134	5424	7383	12170
80	420	770	1225	2150	3485	6031	8209	13531
90	461	846	1347	2364	3831	6630	9024	14874
100	503	922	1468	2577	4176	7228	9838	16216
125	607	1113	1771	3108	5037	8718	11866	19558
150	710	1302	2072	3636	5893	10198	13881	22879
175	813	1491	2374	4166	6752	11685	15905	26216
200	916	1680	2675	4694	7608	13166	17921	29539
250	1121	2057	3274	5746	9313	16118	21938	36160
300	1336	2452	3902	6848	11099	19209	26145	43094

SIZES 2 1/2" THROUGH 12"

VEL., FPM	30000	30000	30000	30000	30000	30000	24000	24000
PRESS. (PSIG)	REGULATOR or PIPE SIZE (inches)							
	2 1/2	3	4	5	6	8	10	12
-10	718	1109	1910	3002	4335	7507	9466	13437
-5	1558	2405	4142	6509	9399	16276	20524	29134
0	2233	3448	5938	9331	13475	23334	29424	41767
5	2979	4600	7922	12449	17978	31131	39256	55723
10	3671	5669	9762	15341	22154	38362	48374	68666
15	4356	6725	11581	18200	26283	45512	57390	81464
20	5033	7772	13383	21032	30372	52594	66320	94139
25	5705	8809	15170	23839	34426	59613	75171	106703
30	6373	9841	16947	26632	38459	66596	83977	119203
40	7692	11878	20454	32143	46418	80378	101355	143871
50	9000	13896	23929	37605	54305	94036	118578	168318
60	10301	15905	27389	43042	62156	107631	135722	192653
70	11576	17874	30779	48370	69851	120955	152523	216502
80	12870	19873	34221	53779	77662	134481	169579	240713
90	14148	21846	37619	59119	85373	147834	186417	264614
100	15424	23817	41012	64452	93074	161169	203233	288484
125	18603	28725	49465	77735	112256	194385	245117	347938
150	21763	33603	57865	90936	131319	227395	286743	407024
175	24936	38503	66303	104197	150470	260557	328560	466382
200	28097	43384	74708	117405	169544	293586	370208	525501
250	34395	53108	91453	143720	207545	359389	453186	643286
300	40991	63293	108992	171283	247348	428313	540098	766655

SATURATED STEAM FLOW TABLE (LB/HR) BASED ON SCHEDULE 40 PIPE

SIZES 3/8" THROUGH 4"

VEL., FPM	15000	15000	15000	15000	15000	15000	15000	10000	10000	10000
PRESS. (PSIG)	REGULATOR or PIPE SIZE (inches)									
	3/8	1/2	3/4	1	1 1/4	1 1/2	2	2 1/2	3	4
-10	14	23	40	65	112	153	252	239	370	637
-5	31	49	87	141	243	331	546	519	802	1381
0	45	71	124	202	349	475	783	744	1149	1979
5	59	95	166	269	465	633	1044	993	1533	2641
10	73	117	204	331	573	781	1287	1224	1890	3254
15	87	138	243	393	680	926	1526	1452	2242	3860
20	100	160	280	454	786	1070	1764	1678	2591	4461
25	114	181	318	515	891	1213	1999	1902	2936	5057
30	127	202	355	575	996	1355	2233	2124	3280	5649
40	153	244	428	694	1202	1635	2696	2564	3959	6818
50	179	286	501	812	1406	1913	3154	3000	4632	7976
60	205	327	574	930	1609	2190	3610	3434	5302	9130
70	231	367	645	1045	1808	2461	4057	3859	5958	10260
80	257	408	717	1162	2010	2736	4510	4290	6624	11407
90	282	449	788	1277	2210	3008	4958	4716	7282	12540
100	307	489	859	1392	2409	3279	5405	5141	7939	13671
125	371	590	1036	1679	2906	3955	6519	6201	9575	16488
150	434	691	1212	1964	3399	4627	7626	7254	11201	19288
175	497	791	1389	2251	3895	5302	8739	8312	12834	22101
200	560	892	1565	2536	4389	5974	9846	9366	14461	24903
250	686	1091	1915	3104	5373	7313	12053	11465	17703	30484
300	817	1301	2283	3700	6403	8715	14365	13664	21098	36331
400	1065	1696	2976	4823	8347	11361	18725	17812	27502	47360
500	1326	2110	3703	6002	10387	14138	23303	22166	34225	58936
600	1591	2532	4444	7202	12464	16965	27963	26599	41	70724

SIZES 5" THROUGH 24"

VEL., FPM	10000	10000	10000	8000	8000	8000	8000	8000	8000	8000
PRESS. (PSIG)	REGULATOR or PIPE SIZE (inches)									
	5	6	8	10	12	14	16	18	20	24
-10	1001	1445	2502	3155	4479	5413	7071	8951	11122	16087
-5	2170	3133	5425	6841	9711	11737	15332	19407	24115	34878
0	3110	4492	7778	9808	13922	16826	21980	27822	34572	50002
5	4150	5993	10377	13085	18574	22448	29325	37119	46124	66710
10	5114	7385	12787	16125	22889	27662	36136	45740	56836	82204
15	6067	8761	15171	19130	27155	32818	42871	54265	67430	97526
20	7011	10124	17531	22107	31380	37924	49542	62708	77921	112700
25	7946	11475	19871	25057	35568	42986	56153	71078	88321	127741
30	8877	12820	22199	27992	39734	48021	62731	79404	98667	142706
40	10714	15473	26793	33785	47957	57959	75713	95836	119086	172238
50	12535	18102	31345	39526	56106	67808	88579	112121	139321	201505
60	14347	20719	35877	45241	64218	77611	101385	128331	159464	230638
70	16123	23284	40318	50841	72167	87219	113936	144217	179204	259189
80	17926	25887	44827	56526	80238	96972	126677	160345	199244	288174
90	19706	28458	49278	62139	88205	106601	139255	176265	219027	316787
100	21484	31025	53723	67744	96161	116217	151817	192166	238785	345363
125	25912	37419	64795	81706	115979	140168	183105	231770	287997	416540
150	30312	43773	75798	95581	135675	163972	214199	271128	336904	487276
175	34732	50157	86852	109520	155461	187884	245437	310668	386036	558337
200	39135	56151	97862	123403	175167	211700	276549	350048	434970	629112
250	47907	69182	119796	151062	214429	259150	338534	428507	532463	770120
300	57094	82449	142771	180033	255552	308850	404358	510687	634579	917814
400	74426	107479	186112	234685	333130	402609	525936	665717	827219	1196436
500	92620	133751	231607	292053	414562	501024	654498	828448	1029428	1488898
600	111143	160501	277928	350464	497474	601229	785398	994137	1235314	1786677

REG
SIZING

SELECTING PRESSURE PILOTS

Any of the Main Valves described in the Main Valve Section can be combined with any of the Pilots listed below to produce the SPENCE Pressure Regulator. This Regulator will reduce and regulate a steady

or varying initial pressure, within the range specified, so as to maintain a constant, adjustable, predetermined delivery pressure. The table below lists the principal Pressure Pilots.

PRESSURE REGULATOR PILOTS

Type	Service Conditions						Delivery Pressure		Normal Accuracy ±	Diaphragm		Loading	Main Valve		
	Cast Iron		Bronze		Cast Steel					Diameter inches	Material				
	Maximum Initial Pressure psi	Maximum Temperature °F	Maximum Initial Pressure psi	Maximum Temperature °F	Maximum Initial Pressure psi	Maximum Temperature °F	Minimum psi	Minimum psi							
D	250	450	-	-	600	750	3	150	1psi	3/2	St. Stl.	Spring	E Series		
D2	250	450	-	-	600	750	100	300	2 psi	3/2	St. Stl.	Spring	E Series		
D5	250	450	-	-	-	-	1	25	1/2 psi	5-3/4	St. Stl.	Spring	E Series		
D120	250	450	-	-	600	750	5	150	1psi	4-1/2	St. Stl.	Spring	E Series		
A73	250	450	-	-	600	750	See response curves on A Pilot Product Page 39		1/2 psi	3-1/2-7-1/4b	St. Stl.	Air	E Series		
A53	250	450	-	-	600	750			1/2 psi	3-1/2_5-3/4b	St. Stl.	Air	E Series		
A	250	450	-	-	600	750			1/2 psi	3-1/2	St. Stl.	Air	E Series		
A35	250	450	-	-	-	-			1/8 psi	5-3/4-3-1/2b	St. Stl.	Air	E Series		
A54	250	450	-	-	600	750			1psi	4-1/2_5-3/4b	St. Stl.	Air	E Series		
A70	250	450	-	-	600	750			2 psi	7-1/4	St. Stl.	Air	E Series		
A86	250	450	-	-	600	750			1/2 psi	4-1/2	St. Stl.	Air	E Series		
A87	250	450	-	-	600	750			1/2 psi	7-1/4	St. Stl.	Air	E Series		
A85	250	450	-	-	600	750			1/2 psi	3-1/2_5-3/4b	St. Stl.	Air	E Series		
A84	250	450	-	-	600	750			1/2 psi	3-1/2	St. Stl.	Air	E Series		
A83	250	450	-	-	600	750			1/2 psi	3-1/2	St. Stl.	Air	E Series		
A82	250	450	-	-	-	-			1/8 psi	5-3/4	St. Stl.	Air	E Series		
Safety Pilot	-	-	300	500	600	750			5	175	-	3-1/2	St. Stl.	Spring	E Series
P125	250	450	-	-	600	750			5	175	1psi	4-1/2	St. Stl.	Spring	E Series

NOTES ON SELECTION OF PILOTS

D SERIES PILOTS meet the requirements of the majority of all pressure regulator problems. They are spring-loaded. Other Pilots are modifications of the D Series for specific purposes.

A SERIES PILOTS are air-loaded. These Pilots are recommended where frequent changes in setting must be made and the Regulator is not easily accessible.

In any one Series of Pilots a larger Diaphragm will produce closer accuracy of control but with less range in delivery pressure.

Water Service Pilot operated Regulators are not uniformly satisfactory as water reducing valves unless the delivery system has the ample cushioning afforded by an elevated tank or air chamber. When the flow is intermittent to an inflexible system, the SPENCE Type D34 Direct Operated Pressure Reducing Valve is recommended.

SIZING PRESSURE REGULATORS

DATA REQUIRED FOR ORDERING

- SERVICE** Fluid flowing through Regulator.
- INITIAL (INLET) PRESSURE**
 - Maximum/Minimum.
 - Superheat, Gravity, etc.
 - Steam Service-Total Temperature or Degrees Superheat, if any.
 - Air, Gases, Water and Liquids-Temperature and Specific Gravity.
- DELIVERY (OUTLET) PRESSURE** Maximum/Minimum.
- CAPACITY** Maximum required flow through Regulator.
- END CONNECTIONS** Screwed or Flanged. (If flanged, state drilling.)

EXAMPLE

Select size and type Regulator to pass 14,600 lb. steam per hour reducing from 175/150 psi saturated to 40/20 psi. Ends to be flanged, pilot spring loaded and pressure controlled within 2 psi.

- Steam
- 175/150psi
 - None (saturated, 378°F total temperature)
- 40/20 psi
- 14,600lb. per hour
- Flanged, if 2 1/2" size or larger

SELECTION OF TYPE AND SIZE OF REGULATOR

MAIN VALVE	PILOT
<p>A. TYPE -See Selection Criteria for Steam, Air, Gases or Water and Liquids in beginning of this Section.</p> <p>B. SIZE-See applicable Valve Capacity Tables in this Section</p> <p>C. MATERIAL- See Main Valve Selection Chart in Technical Reference Section or individual Product Pages.</p> <p>D. ACCESSORIES-See Accessories in Other Products Section</p>	<p>See Selection Criteria and Selection Charts opposite.</p> <p>See Pilot Selection Chart opposite or individual Product Pages</p>

SELECTION OF TYPE AND SIZE OF REGULATOR

MAIN VALVE	PILOT
<p>A. Since maximum Delivery Pressure is less than 75% of minimum Initial Pressure and the least pressure drop exceeds required "minimal differential". SELECT TYPE E</p> <p>B. For 14,600 lb. per hour and 150 psi minimum Initial Pressure Economical: SELECT 3" FULL PORT Engineered: SELECT 4" NORMAL PORT</p> <p>C. For 175 psi, 378°F: SELECT CAST IRON, FLANGED 250 LB</p> <p>D. None required in this case</p>	<p>Since maximum Initial Pressure 175 psi, Total Temperature 378°F maximum Delivery Pressure 40 psi, Pilot spring loaded and required accuracy 2 psi: SELECT TYPE D</p> <p>For 175 psi, 378°F: SELECT CAST IRON</p> <p>D. None required in this case</p>

REG
SIZING

ECONOMICAL SOLUTION: 3" FULL PORT SPENCE TYPE ED, CAST IRON BODY, 250 LB. FLANGED ENDS ENGINEERED SOLUTION: 4" NORMAL PORT SPENCE TYPE ED, CAST IRON BODY, 250 LB. FLANGED ENDS.

NOTE: Pressure Regulators should always be protected by properly designed Strainers.

PRESSURE RECOVERY FACTORS FOR REGULATORS

TRIM	F _r (Liquid Service)									
	10%	20%	30%	40%	50%	60%	70%	80%	90%	100%
Normal	0.998	0.997	0.996	0.990	0.980	0.968	0.958	0.950	0.944	0.940
Full	0.998	0.996	0.987	0.980	0.970	0.960	0.948	0.936	0.928	0.925
Parabolic	0.957	0.956	0.955	0.954	0.953	0.952	0.95	0.945	0.942	0.938

TRIM	X _r (Gas Service)									
	10%	20%	30%	40%	50%	60%	70%	80%	90%	100%
Normal	0.837	0.835	0.833	0.823	0.807	0.787	0.771	0.758	0.749	0.742
Full	0.837	0.833	0.818	0.807	0.790	0.774	0.755	0.736	0.723	0.719
Parabolic	0.769	0.768	0.766	0.764	0.763	0.761	0.758	0.750	0.745	0.739

SIZING SERIES 2000 TEMPERATURE REGULATORS PERFORMANCE VARIABLE

EXAMPLE FOR HEATING SERVICE.....

The maximum anticipated flow requirements for a regulator on heating service is 500 lbs. of steam per hour. The unit steam pressure is 50 psig and the downstream pressure is essentially zero because the steam downstream is discharged into an open drain.

ANSWER: Locate 50 psi on the inlet pressure scale on the left side of the Series 2000 Capacity Chart. Choose the outlet pressure line "up to 20" psig because the downstream pressure is essentially zero. Follow the "up to 20" outlet pressure line until you come to the value closest to 500 lbs. of steam per hour (in this case, 505). Read upward to the valve size and we see that the 1/2" single seated valve is the correct size. To size for three-way valves, use single seated capacities 1/2" through 2" size.

NOTE: FORMULAS FOR EXACT CALCULATIONS.

If the outlet pressure is equal to or less than 53% of the absolute inlet pressure:

$$Q \text{ (lbs steam/hr)} = 1.5 \times C_v \times \text{inlet pressure (psia)}$$

If the outlet pressure is greater than 53% of the absolute inlet pressure:

$$Q \text{ (lbs steam/hr)} = 3 \times C_v \times \text{pressure drop (psi)} \times \text{outlet pressure (psia)}$$

STEAM FLOW REQUIREMENTS

Use the top chart on this page to determine the pounds of steam per hour required to raise the temperature in tank of known capacity to the required temperature. Determine the rise in temperature (control temp. - room temp.) on the left hand column, read the corresponding pounds of steam per hour under the corresponding gallons of water to be heated. Use the lbs. steam/hr. figure in the chart on the opposite page to determine valve size.

Formula for converting the length, width and depth of solutions (all measured in feet) to gallons of solution: Gallons=7.48 x length x width x depth.

EXAMPLE FOR COOLING SERVICE

Find the correct regulator valve size that will feed a compressor intercooler that requires 100 gallons of water per minute under maximum operating conditions. The supply (inlet) pressure (P1) is 60 psi and the downstream pressure (P2) under maximum flow conditions is 20 psi. The 20 psi pressure is required to force the full flow of water through the compressor's cooling system. Inlet pressure must not exceed maximum upstream pressure, per the Series 2000 Temperature Regulator Product Pages.

ANSWER: The pressure drop permitted across the regulator is P1 minus P2 (40 psi). In the Water Capacity Table (right), locate 40 psi in the differential pressure column and read across to the required gallons per minute. Read to the highest value (in this case, 130 GPM). The chart indicates that a 1 1/4" double seated valve is required. To size 3-way valve, use single seated capacities 1/2" through 2" size.

30°F span from fully open to fully closed
Oversized valve can provide narrower spans-Consult Factory

STEAM FLOW REQUIREMENTS

Temp. Rise °F	GALLONS OF WATER HEATED PER HOUR										
	25	50	75	100	150	200	300	400	500	750	1000
	LBS. OF STEAM PER HOUR										
10	2	4	6	8	12	17	25	33	42	63	83
20	4	8	12	17	25	33	50	67	83	120	167
30	6	12	19	25	37	50	70	100	120	190	250
40	9	17	25	33	50	66	100	130	170	250	330
50	11	21	31	42	63	84	125	170	210	310	420
60	13	25	37	50	75	100	150	200	250	370	500
80	17	33	50	67	100	130	200	270	330	500	670
100	21	42	63	83	120	170	250	330	420	630	830
120	25	50	75	100	150	200	300	400	500	750	1000
140	29	58	88	117	175	230	350	470	580	880	1170
160	33	66	100	133	200	270	400	530	660	1000	1330

RATED WATER CAPACITY TABLE

PSIG Diff. Press	SINGLE SEATED VALVES						DOUBLE SEATED VALVES					
	1/2	3/4	1	1 1/4	1 1/2	2	1/2	3/4	1	1 1/4	1 1/2	2
	WATER FLOW—U.S. GALLONS PER MINUTE											
5	12	15	20	32	34	38	18	23	29	46	55	74
10	17	22	29	45	48	54	25	33	41	65	78	104
15	20	27	35	55	59	67	31	40	50	80	96	128
20	23	31	41	64	68	77	35	47	58	92	111	148
25	26	34	46	72	76	86	40	52	65	103	124	165
30	29	38	50	78	83		43	57	71	113	136	181
40	33	43	58	90			50	66	82	130	157	209
50	37	48	65				56	74	91	146	175	233
60	40	53	71				61	81	100	160	192	256
70	44	57					66	87	108	172	207	276
80	47	61					71	93	115	184	222	295
90	50	65					75	99	122	195	235	313
100	52						79	104	129	206	248	330
110	55						83	109	135	216	260	346
120	57						87	114	141	226	272	361
130	60						90	119	147	235	283	376
140	62						94	123	153	244	293	390
150							97	127	158	252	304	404
160							100	132	163	261	314	417
170							103	136	168	269	323	430
180							106	140	173	276	333	443
190							109	143	178	284	342	455
200							112	147	182	291	351	467
210							115	151	187	299	359	478
220							118	154	191	306	368	489
230							120	158	196	312	376	500
240							123	161	200	319	384	511
250							125	164	204	326	392	522

SERIES 2000 TEMPERATURE REGULATOR SELECTION

DIRECT, REVERSE ACTING AND THREE WAY FLOW AND PRESSURE RATINGS PSIG (BAR)

SIZE	Single Seat				Double Seat				Three Way			
	Type Number		Flow Coefficient C _v	Max. Upstream Pressure	Type Number		Flow Coefficient C _v	Max. Upstream Pressure	Type Number	Flow Coefficient C _v	Max. Difference Between Inlet Pressures*	
	Direct	Reverse			Direct	Reverse						
1/2" C			.40	250 (17.2)	NOT AVAILABLE IN DOUBLE SEAT				NOT AVAILABLE IN DOUBLE SEAT			
1/2" D			1.00									
1/2" E			1.80									
1/2" A			3.29									
1/2" B			4.29	200 (13.8)								
1/2" T			5.22	140 (9.7)	2030	2040	7.93	250 (17.2)	2050	5.22	140 (9.7)	
3/4" T	2010	2020	6.85	90 (6.2)						10.4	6.85	90 (6.2)
1" T			9.15	65 (4.5)						12.9	9.15	65 (4.5)
1 1/4" T			14.3	40 (2.8)						20.6	14.3	40 (2.8)
1 1/2" T			15.1	40 (2.8)						24.8	15.1	30 (2.1)
2" T			17.2	20 (1.4)						33.0	17.2	20 (1.4)
				20 (1.4)								

HOW TO SELECT RANGE AND BULB SIZE.....

- Select a temperature range with the control point in the upper half of the temperature range.
- Determine line length required (8' is standard).
- Use line length and temperature range to find correct bulb size in chart at right

EXAMPLE:

Control point: 130°F. Temperature range: 65/140°F. Line length: 15'

SOLUTION:

Bulb size: extra large - G = 15-5/8"

RANGES, BULB SIZES AND MAXIMUM LINE LENGTHS

Short Ranges (Gold Spring)		Long Ranges (Silver Spring)		Bulb Size	tMax. Line Length	Maximum Over-Temperature	
°F	°C	°F	°C			°F	°C
45 to 115	7.2 to 46	45 to 145	7.2 to 63	X-Large	40 Ft.	450	232
65 to 140	18 to 60	65 to 170	18 to 77	Large X-Large	15 Ft. 40 Ft.	450	232
120 to 200	49 to 93	120 to 230	49 to 110	Small	40 Ft.	300	149
240 to 310	116 to 154	240 to 340	116 to 171	Small	40 Ft.	350	177
280 to 375	138 to 190	280 to 415	138 to 212	Small	40 Ft.	450	232

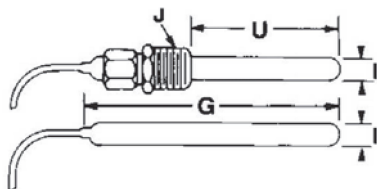

BULB DIMENSIONS* INCHES (MM)

Bulb Sizes	G			U	I			J (NPT)
	Copper	Stain. Stl	Coated		Plain	Union	Well	
Small	13 3/8 (340)	13 1/4 (337)	11 3/8 (289)	10 1/2 (267)	5/8 (16)	5/8 (16)	3/4 (19)	3/4 or 1
Large	15-5/8 (25)	15 1/8 (25)	13 1/4 (337)	12-1/2 (317)	1 (25)	1 (25)	1 1/8 (29)	1
Extra Large	19 (483)	18 5/8 (473)	19 (483)	16 (406)	1 (25)	1 (25)	1 1/8 (29)	1

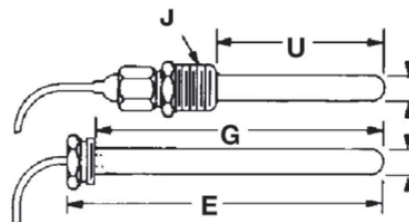

GAS SERVICE BULB AND WELL DIMENSIONS INCHES (MM)

E	G	I		U	J (NPT)
		Bulb	Well		
8 1/4 (210)	7 3/8 (187)	25/32 (20)	15/16 (24)	7 11/16 (195)	1

SERIES 2000 TEMPERATURE REGULATOR

CODE SELECTIONS CHART

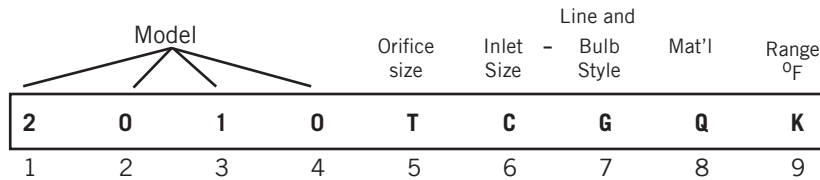

Model -
Position 1, 2, 3 & 4 2010 = Single Seat, Direct Acting 2020 = Single Seat, Reverse Acting 2030 = Double Seat, Direct Acting 2040 = Double Seat, Reverse Acting 2050 = Three Way

Orifice -
Position 5 A B C D E T = Standard

Inlet Size
-Position 6 C = 1/2 D = 3/4 E = 1 F = 1 1/4 G = 1 1/2 H = 2
Line and Bulb Style
Position 7 G = Indicating N = Non-indicating

Material -
Position 8 O = Copper Bz Armor 8' R = Copper Bz Armor 15' N = Copper Bz Armor 25' P = Copper Bz Armor 40' T = SS Unarmored 8' V = SS Unarmored 15' W = SS Unarmored 25' X = SS Unarmored 40' Z = Other

Range °F -
Position 9 C = 45/115 D = 45/145 E = 65/140 F = 65/170 J = 120/200 K = 120/230 L = 240/310 M = 240/340 N = 280/375 P = 280/415 Z = Other

+For SS Armored Thermal Assembly Material, add (-TV) at the end of the code (ex.: 2010TC-NTH-TV)

+Small bulb standard for J-1 range and higher.

Extra large bulb standard for D range and lower.

Large bulb standard for E and F range

THERMOWELL

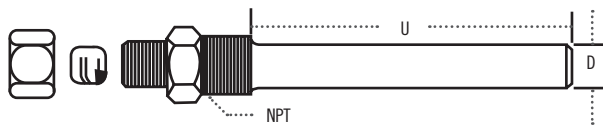

UNION BUSHINGS

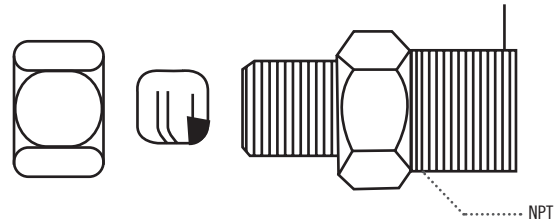

WELLS

Cat. No.	Bulb Size	Material	Inches		(mm)	
			Bulb Dia.	NPT	U	Well Dia.
WAL99A	S	Brass		3/4 (19)		
WAL99B	S	Brass	5/8	1 (25)	10 1/2	3/4
WAL99G	S	316 St. St.	(16)	3/4 (19)	(267)	(19)
WAL99H	S	316 St. St.		1 (25)		
WAL99J	L	Brass			12-1/2(318)	
WAL99K	X	Brass	1	1	16 (406)	1 1/8
WAL99Q	L	316 St. St.	(25)	(25)	12-1/2(318)	(29)
WAL99R	X	316 St. St.			16 (406)	

UNION BUSHINGS

Cat. No.	Bulb Size	Material	Inches (mm)	
			Bulb Dia.	NPT
WAL98A	S	Brass		3/4
WAL98B	S	Brass	5/8	1
WAL98C	S	St. St.	(16)	3/4
WAL98D	S	St. St.		1
WAL98E	L & X	Brass	1	1
WAL98F	L & X	St. St.	(25)	1

Thermowells and union bushing are utilized as separate items and should be specified on separate line

RATED STEAM CAPACITY TABLE

SERIES 2000 TEMPERATURE REGULATOR

VALVE SIZE		SINGLE SEATED VALVES										DOUBLE SEATED VALVES						
Inlet Pressure PSIG	Outlet Pressure PSIG	1/2 C	1/2 D	1/2 E	1/2 A	1/2 B	1/2	3/4	1	1 1/4	1 1/2	2	1/2	3/4	1	1 1/4	1 1/2	2
DRY SATURATED STEAM—LBS. OF STEAM/HR																		
5	UP to 9" HG. VAC. 6" HG. VAC. 2	12	30	53	97	130	155	200	270	420	450	510	235	305	380	610	735	975
		11	29	52	95	125	150	195	265	415	440	500	230	300	375	600	720	960
		8	21	38	70	90	110	145	195	305	320	365	170	220	275	440	525	700
10	UP to 3" HG. VAC. 3	15	35	65	120	160	195	255	340	530	565	635	295	385	480	765	920	1220
		13	33	60	110	145	175	230	305	480	510	575	265	345	430	690	830	1100
		10	24	44	80	105	125	165	220	345	370	415	190	250	310	500	600	800
20	UP to 4 10 15	21	52	95	170	225	270	355	475	745	790	895	415	540	670	1070	1290	1720
		19	47	85	155	200	245	325	430	675	715	810	375	490	610	970	1170	1550
		15	37	66	120	155	190	250	335	525	555	630	290	380	470	755	910	1200
30	UP to 10 15 25	27	67	120	220	290	350	460	615	960	1020	1150	530	695	865	1380	1660	2210
		25	63	115	210	270	330	435	580	905	960	1090	500	660	815	1300	1570	2090
		17	42	75	140	180	220	290	385	605	640	730	335	440	545	870	1050	1390
40	UP to 15 20 30	33	82	150	270	350	430	560	750	1170	1250	1410	650	885	1060	1690	2030	2710
		32	79	140	260	340	415	540	725	1130	1210	1380	625	820	1020	1630	1960	2610
		25	63	115	210	270	330	435	580	905	960	1100	505	660	820	1300	1570	2090
50	UP to 20 30 40	39	97	175	320	415	505	665	890	1380	1470	1650	770	1010	1250	2000	2400	3200
		36	90	160	295	385	470	615	820	1250	1340	1520	710	935	1150	1850	2220	2960
		28	70	125	230	300	365	480	640	1000	1070	1250	555	730	905	1440	1740	2310
60	UP to 25 30 50	45	112	200	370	480	585	770	1020	1550	1640	1820	890	1160	1440	2310	2780	3700
		44	110	198	360	470	575	755	1000	1480	1570	1750	870	1140	1410	2260	2720	3620
		30	75	135	250	325	400	525	700	1100	1170	1350	605	795	985	1570	1890	2520
70	UP to 30 40 60	51	127	230	420	545	665	870	1150	1700	1790	1970	1010	1320	1640	2610	3150	4190
		49	122	220	400	520	635	830	1100	1630	1720	1900	965	1260	1570	2500	3010	4010
		33	82	150	270	350	430	560	750	1130	1210	1390	650	855	1060	1690	2030	2700
80	UP to 35 50 70	57	140	255	465	610	740	975	1280	1850	1940	2120	1120	1470	1830	2920	3520	4690
		53	130	240	435	565	690	905	1200	1780	1870	2050	1050	1370	1705	2720	3280	4360
		35	85	155	285	375	455	600	790	1170	1250	1430	690	910	1120	1800	2160	2880
90	UP to 41 60 90	65	155	285	515	675	820	1070	1400	2000	2090	2270	1240	1630	2020	3230	3890	5180
		57	140	255	465	610	740	975	1280	1780	1870	2050	1120	1470	1830	2790	3520	4680
		35	90	165	305	395	480	630	820	1200	1280	1460	730	960	1190	1900	2290	3040
100	UP to 46 70 90	70	170	310	565	740	900	1180	1550	2180	2270	2450	1360	1790	2220	3540	4260	5680
		65	165	295	540	705	855	1120	1450	2050	2140	2320	1300	1700	2110	3380	4060	5410
		40	95	175	320	415	505	655	840	1220	1300	1480	770	1010	1250	2000	2400	3200
110	UP to 52 70 90	75	185	335	615	800	975	1280	1680	2350	2440	2620	1480	1940	2410	3850	4640	6170
		70	175	315	575	750	910	1190	1580	2250	2340	2520	1380	1810	2250	3590	4330	5760
		55	135	245	450	590	715	900	1180	1600	1690	1870	1090	1430	1770	2830	3400	4530
120	UP to 57 80 100	80	200	365	665	865	1050	1380	1820	2550	2640	2820	1600	2100	2600	4160	5010	6670
		75	185	330	605	790	965	1250	1640	2300	2390	2570	1460	1920	2380	3800	4580	6090
		55	145	260	475	615	750	940	1220	1700	1790	1970	1140	1490	1850	2960	3560	4740
130	UP to 62 80 110	85	215	390	715	930	1130	1480	1980	2750	2840	3020	1720	2250	2800	4470	5380	7160
		80	205	370	680	885	1080	1420	1920	2660	2750	2930	1630	2140	2660	4250	5120	6810
		60	150	270	495	645	780	980	1260	1760	1850	2030	1190	1560	1930	3080	3710	4940
140	UP to 68 90 120	95	230	420	765	995	1215	1620	2160	2980	3070	3250	1840	2410	2990	4780	5750	7660
		85	215	390	715	930	1130	1480	1980	2750	2840	3020	1720	2250	2800	4470	5380	7160
		60	155	280	510	670	815	1010	1290	1790	1880	2060	1230	1620	2010	3210	3860	5140
150	UP to 72 100 140	100	245	445	815	1060	1280	1720	2300	3180	3270	3450	1960	2570	3180	5090	6120	8150
		95	240	430	780	1020	1240	1620	2160	3060	3150	3330	1880	2470	3060	4900	5890	7840
		75	190	345	625	820	1000	1280	1660	2260	2350	2530	1510	1980	2460	3930	4730	6290
160	UP to 78 100 140	105	260	470	860	1120	1340	1820	2440	3380	3470	3650	2080	2720	3380	5400	6500	8650
		100	250	450	820	1070	1290	1700	2280	3200	3290	3470	1970	2590	3210	5120	6170	8210
		65	165	300	550	715	880	1100	1440	1940	2030	2210	1320	1730	2150	3440	4140	5500
170	UP to 83 100 140	110	275	500	810	1190	1410	1920	2580	3570	3660	3840	2190	2880	3570	5700	6870	9140
		105	270	485	885	1150	1370	1780	2380	3320	3410	3590	2130	2790	3470	5540	6660	8870
		80	205	370	670	875	1070	1350	1750	2420	2510	2690	1620	2120	2630	4210	5070	6740
180	UP to 89 120 160	115	290	525	960	1250	1470	2000	2700	3760	3850	4030	2310	3030	3760	6010	7240	9640
		110	270	485	890	1150	1370	1780	2380	3320	3410	3590	2140	2800	3480	5550	6690	8900
		70	175	320	585	760	940	1180	1580	2180	2270	2450	1400	1840	2290	3650	4400	5850
190	UP to 95 120 160	125	305	555	1010	1310	1530	2080	2820	3960	4050	4230	2430	3190	3960	6320	7610	10100
		115	290	525	960	1250	1470	1980	2700	3760	3850	4030	2310	3030	3760	6000	7220	9610
		85	215	390	715	930	1130	1480	1980	2750	2840	3020	1720	2260	2800	4470	5380	7160
200	UP to 100 120 180	130	320	580	1060	1380	1600	2180	2960	4150	4240	4420	2550	3350	4150	6630	7980	10600
		125	310	560	1020	1330	1550	2080	2820	4010	4100	4280	2470	3240	4010	6410	7720	10300
		75	185	335	615	805	990	1270	1670	2270	2360	2540	1480	1940	2410	3850	4640	6180
210	UP to 105 120 180	135	335	605	1110	1450	1670	2280	3100	4350	4440	4620	2670	3500	4350	6940	8360	11100
		130	330	595	1080	1400	1620	2180	2960	4260	4350	4530	2620	3430	4260	6800	8190	10900
		90	230	415	755	945	1130	1410	1810	2410	2500	2680	1820	2380	2960	4720	5680	7560
220	UP to 110 140 200	140	350	635	1160	1500	1720	2340	3200	4540	4630	4810	2790	3660	4540	7250	8730	11600
		135	335	600	1100	1450	1670	2280	3100	4300	4390	4570	2640	3470	4300	6870	8270	11000
		80	195	355	645	835	1020	1260	1660	2260	2350	2530	1560	2040	2530	4050	4870	6480
230	UP to 115 140 200	145	365	660	1210	1550	1770	2400	3300	4680	4770	4950	2910	3810	4730	7560	9100	12100
		140	355	635	1160	1500	1720	2340	3200	4560	4650	4830	2800	3680	4560	7290	8780	11700
		95	240	435	790	975	1160	1440	1840	2440	2530	2710	1910	2500	3100	4960	5970	7940
240	UP to 120 160 200	155	380	690	1250	1650	1870	2520	3460	4880	4970	5150	3030	3970	4930	7870	9470	12600
		140	35															

SELECTING TEMPERATURE PILOTS

Any of the Main Valves described in the Main Valve Section can be combined with any of the Pilots listed below, to produce the SPENCE Temperature Regulator. This Regulator is designed to control the flow of fluid to a heating or cooling element so as to maintain a constant, adjustable, precise predetermined temperature. Pilots fully stroke valve within 5°F. The table below lists the principal Temperature Pilots.

The Thermostats of these SPENCE Pilots are of the Vapor Tension Type. They are ruggedly constructed and will not be injured by overheating.

These SPENCE Temperature Pilots can be furnished with 150°F range of temperature adjustment on special order. It should be noted that since heavier Adjusting Springs are required for this greater range the regulation will not be quite so accurate.

TEMPERATURE RANGES

20°F to 120°F 150°F to 300°F Thermostats can be
 50°F to 150°F 170°F to 270°F furnished for temperatures
 70°F to 170°F 250°F to 350°F higher than 350°F on
 120°F to 220°F special order.

TEMPERATURE REGULATOR PILOTS

Type	Service Conditions						Delivery Pressure Maximum psi	Operating Characteristics	Main Valve
	Cast Iron		Cast Bronze ^a		Cast Steel				
	Maximum Initial Pressure psi	Maximum Temperature °F	Maximum Initial Pressure psi	Maximum Temperature °F	Maximum Initial Pressure psi	Maximum Temperature °F			
T134	250	450	-	-	600	750	20	E Series Cascade Control-Closes on rise in temperature-controls delivery pressure-decreases delivery pressure as temperature increases and vice versa-spring loaded pressure control	
T124	250	450	-	-	-	125			
T14	250	450	-	-	600	750	-		
T14D	250	450	-	-	600	750	150		
T14D2	250	450	-	-	600	750	300		
Safety Pilot	-	-	300	500	-	-	-		Prevents excessive temperature rise.

^aBronze Body Pilots are recommended for water service.

AIR CONTROLLED TEMPERATURE PILOTS

SPENCE Air Control Pilots, listed below, have been developed to meet signal onto a pressure regulator, the EAT Series temperature control special conditions when used in conjunction with A Series Pressure reduces steam pressure to an adjustable limit as well as regulating Pilots. The fast bi-metal thermostats have a 200°F adjustable range output temperature. and protection against damage from over-heating. By cascading an air

Type	Bulb Style	Bulb Material	Bulb Mounting	Range OF	Maximum Bulb Temperature °F	Control Mode	Action
T61	No. 736	Bronze	1/2 NPT	50-250	350	Proportional	Reverse*
	No. 737	St. Stl.1	1/2 NPT	50-250	350	Proportional	Reverse*

* Rising output pressure on falling temperature. This action applied to an EA Series Regulator increases steam flow with decreasing temperature. Direct action available for cooling control.

Rate or reset available on application *Other ranges on application ¹Type 304 ²Type 347 or optional Type 316

NOTES ON SELECTION OF PILOTS

HEATING CONTROL Single Pilot Types T134 and Combination Pilot Type T14D2 reduce the steam pressure as well as regulate the output temperature. A choice should be made according to the maximum required delivery pressure, i.e., the pressure needed in the heater to carry the peak load. Pilot Types T14D and T14D2 in cast steel are designed for initial steam pressures in excess of 500°F.

Of the Air Control Pilots, the Type T61 is the general choice. The Type T60 is used for temperature indication or for remote adjustment. The required heater pressure will determine the choice of the A Series Pilot. See Product Pages.

SIZING TEMPERATURE REGULATORS

DATA REQUIRED FOR ORDERING

1. SERVICE

- (a) Fluid flowing through Regulator.
- (b) Type heater to be controlled.

2. INITIAL (INLET) PRESSURE

- (a) Maximum/Minimum.
- (b) Superheat, Gravity, etc.
 - (1) Steam Service-Total Temperature or Degrees Superheat, if any.
 - (2) Air, Gases, Water and Liquids-Temperature and Specific Gravity.

3. DELIVERY (OUTLET) PRESSURE

Maximum required on heater.

4. CAPACITY

Maximum required flow through Regulator or the following data leading to same:

- (a) Quantity and type of fluid to be heated or cooled.
- (b) Temperature rise or drop, °F.

5. THERMOSTAT CHARACTERISTICS:

- (a) Controlled Temperature, °F-Maximum/Minimum.
- (b) Operation-Open or Close on temperature rise.
- (c) Thermostat Bulb-Style Number and Material.
- (d) Flexible Tubing-Length and Material.

6. END CONNECTIONS

Screwed or Flanged. (If flanged, state drilling)

EXAMPLE

Select size and type Regulator for heating 120 gpm water from 50°F entering temperature to 170°F final temperature in an instantaneous heater. Steam supply at 125 psi pressure to be reduced to 30 psi maximum in heater.

1. (a) Steam
(b) Instantaneous
2. (a) 125 psi
(b) None (saturated, 353°F total temperature)
3. 30 psi
4. See Capacity Tables in this Section.
 - (a) 120 gpm water.
 - (b) $170 - 50 = 120^\circ\text{F Rise}$
 $\frac{120}{2} \times 120 = 7200\text{\#/Hr.}$
5. (a) 170°F-Select standard Temperature Range from facing page to include this final temperature.
(b) Close on temperature rise.
(c) Style No. 700 bronze. (See Options Section)
(d) Ten (10) feet, brass-furnished unless otherwise specified.
6. Flanged, if 2-1/2" size or larger.

SELECTION OF TYPE AND SIZE OF REGULATOR

MAIN VALVE	PILOT
A. TYPE - See Selection Criteria for Steam, Air, Gases or Water and Liquids in beginning of this Section.	See Selection Criteria and Selection Charts opposite.
B. SIZE - See applicable Valve Capacity Tables in this Section	
C. MATERIAL - See Main Valve Selection Chart in Technical Reference Section or individual Product Pages.	See Pilot Selection Chart opposite or individual Product Pages.
D. ACCESSORIES - See Accessories in Other Products Section	

SELECTION OF TYPE AND SIZE OF REGULATOR

PILOT

Since maximum Initial Pressure 125 psi, Total Temperature 353°F maximum Delivery Pressure 30 psi
SELECT TYPE T124

For 125 psi, 353°F:
SELECT CAST IRON

None required in this case

ECONOMICAL SOLUTION: 311 SPENCE TYPE ET124, CAST IRON BODY, NPT 250 ENDS TEMPERATURE RANGE 120-220°F EQUIPPED WITH 10 FEET OF BRASS FLEXIBLE TUBING AND STYLE NO. 700 BRONZE THERMOSTAT BULB.

Temperature Regulators should always be protected by properly designed Strainers.

SELECTING DIFFERENTIAL PRESSURE PILOTS

SPENCE Differential Pressure Regulators may usually be classified in one or the other of the following groups:

1. Control of the delivery pressure at a constant, adjustable, predetermined differential above another source of fluid pressure. This case is illustrated by the use of the SPENCE Type EN Differential Pressure Regulator on a boiler feedwater make-up line to control the delivery pressure of the feedwater at a constant differential above the boiler steam pressure. Another example is the use of the Type EN to control the steam pressure on a

steam atomizing oil burner at a constant differential above the oil pressure at the nozzle.

2. Control of the differential pressure or pressure drop across the Pressure Regulator itself. This case is illustrated by the use of the SPENCE Type EN24 Differential Pressure Regulator installed in parallel with a heat exchanger to maintain a constant differential across it thereby limiting the flow rate of fluid through the heater.

The table below lists the principal Differential Pilots.

TYPE	Service Conditions											Normal Accuracy	Diaphragm		Loading	Operating Characteristics	Main Valve
	Cast Iron			Cast Bronze-			Cast Steel			Differential Pressure			Diameter	Material			
	MAX INITIAL Pressure psi	Max Temperature °F	Max Diaph Pressure psi	Max Initial Pressure psi	Max Temperature °F	Max Diaph Pressure psi	MAX INITIAL Pressure psi	Max Temperature °F	Max Diaph Pressure psi	Min. psi	MAX. psi						
N	250	450	240	300	500	290	600	750	300	3	150	1psi	3112	St. Stl.	Spring	Closes on increase in differential Delivery pressure controlled at set differential above loading pressure Loading Pressure may be any fluid	E Series
N33	250	450	240	300	500	290	600	750	300	3	150	1psi	3112	St. Stl.	Spring	Closes on increase in differential Delivery pressure controlled at set differential above loading pressure Loading Pressure may be any fluid	E Series
N20	250	366	250	300	366	300	300	366	300	3	150	1psi	3112	St. Stl.	Spring	Opens on increase in differential Initial pressure controlled at set differential above loading pressure Loading pressure may be any fluid	E Series

•Bronze Body Pilots are recommended for water service.

NOTES ON SELECTION OF PILOTS

TYPE N AND N33 PILOTS require that the delivery pressure (pressure of fluid discharged from the Regulator) be controlled at a given differential above some separate source of loading pressure.

TYPE N meets the requirements of most boiler feedwater make-up and steam atomizing oil burner differential control problems as described in the first group in the above table.

TYPE N33 is a version of the Type N in which two separated diaphragms are employed to preclude the possibility of contact between the two fluids applied to the pilot.

TYPE N20 is a differential relief pilot which causes the Main Valve to open when its initial pressure exceeds the loading pressure by a set differential.

SIZING DIFFERENTIAL PRESSURE REGULATORS

DATA REQUIRED FOR ORDERING

1. **SERVICE** Fluid flowing through Regulator.
2. **INITIAL (INLET) PRESSURE**
 - (a) Maximum/Minimum.
 - (b) Superheat, Gravity, etc.
 - (1) Steam Service-Total Temperature or Degrees Superheat, if any.
 - (2) Air, Gases, Water and Liquids-Temperature and Specific Gravity.
3. **LOADING PRESSURE**
 - (a) Maximum/Minimum.
 - (b) Fluid
4. **CONTROLLED PRESSURE**
 - (a) Maximum/Minimum.
 - (b) Fluid
5. **DELIVERY PRESSURE** Maximum/Minimum.
6. **CAPACITY** Maximum required flow through Regulator.
7. **END CONNECTIONS** Screwed or Flanged. (If flanged, state drilling.)

EXAMPLE

Select size and type Regulator to control the flow of water from a Motor-Driven Centrifugal Boiler Feed Pump maintaining an Excess or Differential pressure of 50 psi between the boiler feedwater and the boiler steam pressure. The feedwater temperature is 240°F. The boiler steam pressure is 150 psi. Flow 90 gpm at 220 psi pump discharge pressure.

1. Water
2. (a) 220 psi
(b) 240°F
3. (a) 150 psi Boiler Pressure
(b) Steam
4. (a) 200 psi (Loading plus Excess Pressure) (b) Water
5. Identical with Controlled Pressure, Item 4
6. 90 gpm
7. Flanged, if 2 1/2" size or larger

PILOT

See Selection Criteria and Selection Charts opposite.

See Pilot Selection Chart opposite or individual Product Pages

MAIN VALVE

- A. Since pressure drop across valve (Initial Pressure minus Delivery Pressure) is greater than 10 psi:
SELECT TYPE E
- B. For 90 gpm: **SELECT 311**
- C. For 220 psi, 240°F: **SELECT CAST IRON, FLANGED 250 LB.**
- D. For Water Service: Dashpot required.

PILOT

Since Initial Pressure 220 psi, 240°F, Differential (Excess) Pressure 50 psi and the Delivery and Controlled Pressures are the same: **SELECT TYPE N**

For 220 psi, 240°F:

None required in this case.

ANSWER: 3" SPENCE TYPE EN, CAST IRON BODY, 250 LB FLANGED ENDS, EQUIPPED WITH BRONZE DASHPOT AND BRONZE PILOT BODY.

NOTE: Differential Regulators should always be protected by properly designed Strainers.

WATER CAPACITY TABLE-FLOW IN GALLONS PER MINUTE

These flow rates provide a simple method for sizing regulators or water pipes with inlet velocities in the range of 240 to 600 fpm. Spence Regulators have variable seat sizes. The factory will select the proper seat for particular flow and pressure drop. Additional capacity data is available on request.

VALVE OR PIPE SIZE															
1/4	3/8	1/2	3/4	1	1 1/4	1 1/2	2	2 1/2	3	4	5	6	8	10	12
Velocity, fpm															
247	251	255	262	270	277	285	300	315	330	360	390	420	480	540	600
1.3	2.5	4.0	7.3	12	22	30	52	78	127	238	405	630	1250	2210	3490

SELECTING BACK PRESSURE PILOTS

Any of the Main Valves described in the Main Valve Section can be combined with any of the Pilots listed below to produce the SPENCE Back Pressure Regulator. Provided the delivery (discharge) pressure is sufficiently below the desired back pressure to operate the Regulator, it will maintain a steady back pressure regardless of fluctuations in the load. The Pilot is guaranteed to shut tight when the back pressure falls below a predetermined setting. The table below lists the principal

Back Pressure Pilots. **THE SPENCE BACK PRESSURE REGULATOR IS NOT A SAFETY VALVE AND SHOULD NEVER BE USED AS SUCH.**

The discharge pressure must always be low enough in relation to the back pressure to provide the required minimum differential listed in the Main Valve Selection Chart in the Technical Reference Section.

BACK PRESSURE REGULATOR PILOTS

TYPE	Service Conditions							Diaphragm		Main Valve
	Cast Iron		Cast Steel		Differential Pressure			Diameter	Material	
	Maximum Initial Pressure psi	Maximum Temperature °F	Maximum Initial Pressure psi	Maximum Temperature °F	Minimum psi	Maximum psi	Normal Accuracy ±			
Q	150	366	150	366	3	150	1 psi	3 1/2	St. Stl.	E Series
Q2	250	450	600	750	100	400	2 psi	3 1/2	St. Stl.	E Series
Q73 ^b	150	366	150	366	3	150	112 psi	3 1/2 - 7 1/4	St. Stl.	E Series

^bType Q73 is air adjusted, all others are spring loaded.

^cThese Pilots have dual diaphragms, the first size being the control diaphragm and the second, the air loading diaphragm.

NOTES ON SELECTION OF PILOTS

TYPE Q SERIES meet the requirements of the majority of all back pressure problems. They are packless and spring or air loaded. The Type Q Pilot can be furnished for service on refrigerants on special order.

In back pressure pilots, a larger Diaphragm will produce closer accuracy of control but with less range in back pressure.

SIZING BACK PRESSURE REGULATORS

DATA REQUIRED FOR ORDERING

- SERVICE** Fluid flowing through Regulator.
- INITIAL (INLET) PRESSURE**
 - Maximum/Minimum.
 - Superheat, Gravity, etc.
 - Steam Service-Total Temperature or Degrees Superheat, if any.
 - Air, Gases, Water and Liquids-Temperature and Specific Gravity.
- DISCHARGE (OUTLET) PRESSURE** Maximum/Minimum.
- CAPACITY** Maximum required flow through Regulator.
- END CONNECTIONS** Screwed or Flanged. (If flanged, state drilling.)

SELECTION OF TYPE AND SIZE OF REGULATOR

MAIN VALVE

PILOT

A. TYPE -See Selection Criteria for Steam, Air, Gases or Water and Liquids in beginning of this Section.

See Selection Criteria and Selection Charts opposite.

B. SIZE -See applicable Valve Capacity Tables in this Section.

C. MATERIAL - See Main Valve Selection Chart in Technical Reference Section or individual Product Pages.

See Pilot Selection Chart opposite or individual Product Pages.

D. ACCESSORIES -See Accessories in Other Products Section.

SELECTING PUMP GOVERNOR PILOTS

SPENCE Pump Governors are classified in the following groups:

1. Excess Pressure Pump Governor which is illustrated by the SPENCE Type EN Differential Pressure Regulator. Although this Regulator is not a Pump Governor, it is recommended to govern the steam supply to boiler feed pump where it is desired to maintain the pump discharge pressure at a constant, adjustable differential pressure in excess of the boiler steam pressure.

2. Differential Control for electric motor-driven centrifugal pumps which is illustrated by the SPENCE Type EN Differential Pressure Regulator. Although this Regulator is not a Pump Governor, it is recommended to maintain a constant, adjustable differential between the feedwater pressure and the boiler steam pressure; i.e., a constant pressure drop across the feedwater regulator.

The table below lists the principal Pump Governor Pilots.

PUMP GOVERNOR PILOTS

TYPE	Service Conditions						Diaphragm		Main Valve	Type of Control
	Cast Iron		Cast Steel		Differential Pressure		Diameter	Material		
	Maximum Initial Pressure psi	Maximum Temperature °F	Maximum Initial Pressure psi	Maximum Temperature °F	Minimum psi	Maximum psi				
N	250	450	600	500	3 ^b	300 ^b	3 1/2	St. Stl.	E Series	Differential ^c

^bRegulator discharge pressure

^cFor electric motor driven centrifugal pump applications only, differential pressure range 3 to 150 psi

NOTES ON SELECTION OF PILOTS

P SERIES PILOTS are used for constant pressure control. In this Series a larger Diaphragm will produce closer accuracy of control but with less range in pump discharge pressure. TYPE N is a differential pressure Pilot which is applied to the discharge of a constant speed centrifugal pump to effect excess pressure control. The design

of the Pilot requires that the delivery pressure (pressure of fluid discharged from Regulator) be controlled at a given differential above some separate source of loading pressure. In typical service, boiler feedwater flows through the Regulator and is delivered at constant excess pressure above the boiler steam pressure

RATED STEAM CAPACITY TABLE

TYPE E MAIN VALVE - FULL PORT

VALVE INFO PAGE 22

POUNDS OF SATURATED STEAM PER HOUR

PRESSURE-psig		VALVE SIZE (inches)														
INLET	REDUCED	3/8	1/2	3/4	1	1-1/4	1-1/2	2	2-1/2	3	4	5	6	8	10	12
20	0	86	160	309	504	808	1134	1776	2521	4239	6244	9682	14208	25436	40446	63762
25	10	90	168	325	529	848	1190	1864	2645	4449	6553	10161	14911	26695	42447	66917
	0	98	184	354	577	925	1299	2033	2886	4853	7148	11083	16264	29118	46301	72993
30	15	98	182	352	573	919	1290	2019	2866	4821	7101	11009	16156	28924	45992	72505
	0	110	206	398	648	1038	1458	2282	3239	5448	8024	12441	18257	32685	51972	81934
40	25	111	207	400	652	1044	1466	2296	3259	5481	8073	12517	18368	32884	52289	82432
	20	121	227	437	713	1142	1604	2511	3564	5994	8829	13688	20087	35963	57184	90149
	3-0	134	250	482	786	1259	1768	2768	3929	6608	9733	15091	22146	39648	63043	99387
50	35	123	229	442	721	1155	1622	2540	3605	6062	8930	13845	20317	36374	57838	91181
	30	136	253	489	796	1276	1791	2805	3981	6695	9861	15289	22436	40168	63870	100691
	25	145	270	521	849	1361	1911	2992	4247	7143	10522	16313	23939	42859	68150	107437
	6-0	157	294	566	923	1478	2076	3250	4614	7759	11429	17720	26003	46554	74026	116701
60	45	134	249	481	784	1256	1763	2760	3918	6589	9706	15048	22083	39535	62865	99106
	40	148	277	535	871	1396	1960	3069	4356	7326	10791	16731	24552	43955	69893	110185
	35	160	298	575	936	1500	2107	3299	4682	7874	11599	17984	26390	47247	75127	118436
	10-0	181	337	650	1059	1697	2383	3731	5295	8906	13118	20338	29846	53434	84964	133945
75	55	166	309	596	971	1556	2185	3421	4856	8166	12028	18650	27367	48997	77909	122822
	50	179	335	645	1052	1685	2366	3705	5259	8844	13027	20198	29639	53064	84376	133077
	45	190	355	684	1115	1786	2508	3927	5574	9375	13809	21410	31418	56248	89440	141000
	15-0	215	401	774	1261	2021	2837	4442	6305	10604	15620	24218	35539	63626	101172	159496
100	75	207	387	747	1217	1950	2739	4288	6086	10236	15077	23376	34304	61415	97655	153951
	60	243	454	876	1427	2286	3210	5026	7134	11998	17673	27402	40211	71990	114471	180462
	23-0	272	507	978	1594	2554	3587	5616	7971	13406	19747	30617	44929	80437	127901	201635
125	100	232	433	835	1360	2179	3060	4791	6800	11436	16845	26118	38327	68618	109108	172008
	75	296	552	1064	1735	2779	3903	6110	8673	14586	21485	33311	48882	87515	139157	219379
	31-0	328	612	1180	1924	3082	4328	6777	9619	16177	23828	36944	54214	97061	154335	243307
150	125	253	473	912	1487	2382	3345	5238	7434	12503	18416	28544	41902	75018	119285	188057
	100	329	614	1184	1930	3093	4343	6800	9651	16231	23908	37069	54397	97388	154856	244128
	40-0	384	716	1381	2250	3605	5063	7926	11250	18921	27870	43211	63411	113526	180516	284582
175	150	273	510	983	1602	2567	3605	5645	8012	13474	19847	30722	45156	80844	128549	202656
	125	359	670	1293	2106	3375	4739	7420	10532	17712	26090	40451	59361	106275	168986	266405
	100	406	759	1463	2384	3820	5364	8399	11921	20049	29531	45787	67191	120293	191277	301546
	48-0	439	819	1580	2575	4125	5793	9069	12873	21649	31889	49442	72555	129896	206546	325618
200	150	386	721	1390	2266	3630	5098	7981	11328	19051	28062	43509	63848	114308	181760	286542
	125	442	825	1591	2592	4153	5832	9131	12961	21797	32107	49781	73051	130784	207959	327845
	56-0	493	921	1776	2895	4638	6513	10198	14474	24343	35857	55594	81582	146058	232245	366132
225	175	411	768	1481	2414	3868	5431	8504	12070	20299	29900	46358	68029	121793	193662	305306
	150	475	886	1709	2785	4462	6265	9809	13923	23415	34490	53475	78473	140492	223395	352179
	65-0	548	1023	1973	3215	5151	7234	11325	16075	27034	39821	61741	90602	162207	257923	406613
250	200	435	812	1566	2551	4088	5740	8987	12756	21453	31600	48994	71897	128719	204675	322667
	175	505	942	1817	2962	4746	6664	10434	14809	24906	36686	56880	83469	149437	237618	374601
	150	551	1028	1983	3232	5179	7272	11386	16160	27179	40034	62071	91086	163073	259301	408784
	73-0	602	1124	2167	3532	5659	7946	12441	17659	29699	43745	67825	99530	178191	283340	446682

Based on 10% (2 psi minimum) accuracy of regulation.

RATED STEAM CAPACITY TABLE

TYPE E MAIN VALVE - NORMAL PORT

VALVE INFO PAGE 22

POUNDS OF SATURATED STEAM PER HOUR

PRESSURE-psig		VALVE SIZE (inches)														
INLET	REDUCED	3/8	1/2	3/4	1	1-1/4	1-1/2	2	2-1/2	3	4	5	6	8	10	12
20	0	38	87	279	435	603	847	1021	1393	2495	4526	6672	8761	14447	21874	36612
25	10	39	91	291	454	630	884	1066	1454	2604	4724	6965	9145	15081	22833	38217
	0	43	100	319	499	692	971	1171	1597	2861	5190	7652	10047	16567	25084	41983
30	15	43	98	315	492	682	957	1154	1573	2819	5114	7539	9899	16324	24716	41368
	0	49	112	359	561	777	1091	1316	1794	3214	5831	8597	11288	18613	28182	47169
40	25	48	112	357	558	774	1087	1310	1786	3201	5806	8560	11240	18534	28062	46969
	20	53	122	392	612	848	1191	1436	1958	3507	6362	9381	12317	20311	30752	51470
	3-0	59	136	436	681	944	1325	1597	2178	3902	7078	10436	13702	22595	34211	57260
50	35	53	123	395	617	856	1201	1448	1974	3537	6417	9460	12422	20484	31013	51908
	30	59	136	437	682	946	1328	1601	2184	3913	7097	10464	13740	22657	34304	57415
	25	63	146	467	729	1012	1420	1712	2334	4182	7586	11185	14686	24218	36667	61371
	5-0	69	160	511	799	1108	1556	1875	2557	4582	8311	12254	16089	26532	40170	67235
60	45	58	134	429	670	929	1305	1573	2145	3842	6970	10276	13493	22250	33688	56385
	40	65	149	478	746	1035	1452	1751	2388	4278	7760	11440	15022	24771	37505	62773
	35	70	161	514	803	1114	1563	1885	2570	4605	8353	12315	16170	26665	40372	67573
	8-0	79	183	587	917	1272	1786	2152	2935	5259	9539	14064	18467	30452	46106	77170
75	55	72	166	532	831	1152	1618	1950	2659	4764	8642	12741	16729	27587	41768	69909
	50	78	180	577	901	1249	1754	2114	2883	5165	9370	13814	18139	29911	45287	75798
	45	83	191	612	956	1326	1861	2244	3060	5482	9944	14661	19251	31745	48064	80446
	13-0	95	218	699	1092	1515	2126	2563	3495	6262	11359	16747	21990	36261	54901	91890
100	75	90	208	667	1041	1444	2027	2444	3333	5971	10831	15968	20967	34575	52349	87618
	60	106	245	783	1224	1698	2383	2873	3917	7019	12731	18771	24647	40642	61535	102993
	20-0	120	276	884	1381	1915	2688	3240	4418	7916	14360	21172	27799	45841	69406	116168
125	100	101	233	744	1163	1612	2263	2728	3721	6666	12092	17828	23409	38601	58444	97821
	75	129	298	953	1488	2064	2898	3493	4763	8534	15480	22823	29968	49418	74821	125231
	28-0	144	333	1066	1666	2310	3243	3910	5332	9552	17328	25547	33545	55315	83750	140176
150	125	110	254	813	1270	1762	2473	2981	4066	7284	13213	19481	25579	42180	63863	106890
	100	143	331	1059	1654	2294	3221	3882	5294	9485	17205	25367	33308	54925	83160	139188
	36-0	169	390	1247	1949	2702	3794	4573	6236	11173	20267	29881	39235	64699	97958	163956
175	150	119	274	876	1369	1898	2664	3212	4380	7847	14234	20986	27556	45439	68798	115149
	125	156	361	1154	1804	2501	3511	4233	5772	10342	18759	27658	36316	59886	90671	151759
	100	177	410	1311	2048	2840	3986	4806	6553	11741	21297	31400	41229	67987	102937	172289
	44-0	193	446	1427	2230	3092	4341	5233	7135	12784	23190	34190	44893	74028	112083	187598
200	150	168	388	1241	1939	2689	3774	4550	6205	11117	20165	29730	39037	64372	97463	163128
	125	193	445	1423	2224	3084	4329	5219	7117	12751	23129	34101	44776	73836	111792	187111
	52-0	217	501	1605	2507	3477	4881	5884	8023	14375	26075	38444	50478	83239	126029	210940
225	175	179	413	1322	2065	2863	4020	4846	6608	11839	21475	31662	41573	68555	103795	173727
	150	207	477	1528	2387	3310	4647	5602	7639	13686	24826	36602	48060	79251	119991	200834
	59-0	241	557	1782	2784	3861	5420	6534	8910	15964	28958	42694	56059	92442	139963	234262
250	200	189	436	1396	2181	3025	4247	5119	6981	12507	22687	33449	43920	72425	109656	183535
	175	220	507	1624	2537	3519	4940	5955	8120	14548	26389	38907	51087	84243	127549	213483
	150	240	555	1776	2775	3848	5402	6512	8880	15909	28859	42548	55868	92126	139485	233461
	67-0	265	611	1956	3056	4238	5949	7172	9780	17522	31785	46862	61532	101467	153627	257132

Based on 10% (2 psi minimum) accuracy of regulation.

REG
SIZING

RATED STEAM CAPACITY TABLE

TYPE E2 MAIN VALVE

TYPE E2 MAIN VALVE ONLY

Used at such low pressure drops, a 1 psi deviation of reduced pressure at rated capacity is a significant portion of the total drop. It must be accounted for in calculations dealing with a subcritical flow condition.

Also, because E2 valve opening, for 1 psi accuracy of regulation, varies with the pressure drop, a regulation factor K is inserted in the formula

$$Cv = \frac{W}{2.1 K \sqrt{\Delta P^1 (P_1 + P_2^1)}}$$

- Where
- K = Factor from accompanying table
 - Cv = Valve coefficient
 - W = Flow, #/Hr. (saturated steam)
 - ΔP^1 = AP nominal plus 1 psi
 - P_1 = Inlet pressure, psia (psi + 14.7)
 - P_2^1 = Reduced pressure, psia (psi + 14.7)
 - P_2^1 = P_2 nominal (set point value) minus 1 psi
 - ΔP = Pressure drop, psi

NOTE: When computing W for safety valve sizing, use K = 1.0

K-Factor is included in the above tabulations.

SIZE	E2 Cv Valve Coefficient	P Normal	K Factor
3/4	7.6		
1	11.7		
1 1/4	18.9	3	0.635
1 1/2	27.4	4	0.785
2	44	5	0.855
2-1/2	68	6	0.895
3	96	7	0.915
4	143	8	0.928
5	202	9	0.935
6	255	10	0.937
8	465	11	0.938
10	748	12	0.940
12	1118	15	0.940

Pounds of Saturated Steam per Hour

PRESSURE-psig		VALVE SIZE (inches)												
INLET	REDUCED	3/4	1	1/4	1-1/2	2	2-1/2	3	4	5	6	8	10	12
15	12	209	322	521	755	1212	1873	2644	3939	5564	7024	12808	20603	30794
	10	261	401	648	940	1509	2332	3293	4905	6928	8746	15949	25656	38346
	8	297	457	739	1071	1720	2658	3753	5590	7897	9969	18178	29242	43706
	5	335	515	833	1207	1938	2996	4229	6300	8899	11234	20485	32952	49252
	9" HG VAC	378	581	939	1361	2186	3378	4769	7103	10034	12667	23099	37157	55536
12	9	198	305	493	714	1147	1773	2503	3728	5266	6648	12123	19500	29146
	7	246	378	611	886	1422	2198	3103	4622	6529	8242	15030	24177	36136
	5	279	429	693	1005	1613	2493	3520	5243	7406	9350	17050	27426	40992
	11" HG VAC	341	525	848	1229	1974	3051	4308	6417	9064	11442	20865	33563	50166
10	7	190	293	473	686	1101	1702	2402	3579	5055	6381	11637	18719	27978
	5	235	362	584	847	1360	2102	2968	4421	6245	7884	14376	23125	34564
	2	277	427	689	999	1605	2480	3501	5215	7366	9299	16957	27277	40770
	12" HG VAC	316	487	787	1140	1831	2830	3995	5952	8407	10613	19353	31131	46531
9	6	186	287	463	671	1078	1665	2351	3502	4947	6245	11388	18319	27380
	4	229	353	571	827	1329	2053	2899	4318	6099	7700	14040	22585	33757
	2	259	398	643	933	1498	2315	3268	4868	6877	8681	15830	24464	38060
	13" HG VAC	304	468	756	1096	1761	2721	3841	5722	8083	10203	18606	29930	44735
8	5	182	280	452	656	1053	1628	2298	3423	4836	6105	11132	17907	26765
	3	224	345	557	807	1296	2003	2827	4211	5949	7510	13694	22028	32925
	14" HG VAC	292	449	726	1052	1690	2611	3686	5491	7756	9791	17855	28722	42929
7	4	178	273	442	640	1028	1589	2243	3341	4719	5958	10864	17476	26121
	2	218	335	542	786	1262	1950	2752	4100	5792	7311	13332	21446	32054
	15" HG VAC	280	430	695	1008	1618	2501	3531	5259	7429	9379	17102	27511	41119
6	3	173	267	431	624	1003	1549	2188	3259	4603	5811	10596	17044	25476
	1	212	326	527	764	1227	1896	2677	3988	5633	7111	12968	20860	31178
	15" HG VAC	267	411	664	963	1546	2389	3373	5024	7097	8960	16338	26282	39282
5	2	169	260	419	608	976	1508	2129	3172	4481	5656	10314	16592	24799
	0	206	317	512	742	1191	1840	2598	3870	5467	6902	12585	20245	30259
	16" HG VAC	255	392	633	918	1474	2278	3216	4791	6768	8544	15580	25061	37458

RATED STEAM CAPACITY TABLE

TYPE E5 MAIN VALVE - FULL PORT

Pounds of Saturated Steam per Hour

PRESSURE- ψ sig		VALVE SIZE (inches)												
INLET	REDUCED	3/4	1	1-1/4	1-1/2	2	2-1/2	3	4	5	6	8	10	12
20	15	284	437	706	1023	1605	2501	3546	5935	9631	13065	24824	38001	60136
	10	370	570	920	1334	2094	3263	4626	7743	12564	17044	32383	49573	78450
	0	435	670	1083	1570	2463	3838	5442	9109	14780	20051	38097	58320	92292
25	10	305	469	758	1099	1724	2686	3809	6375	10345	14033	26663	40817	64593
	15	402	619	1000	1449	2275	3544	5025	8411	13647	18514	35176	53849	85217
	10	457	703	1136	1647	2585	4028	5712	9560	15512	21043	39982	61205	96858
	0	498	767	1240	1797	2820	4394	6230	10428	16920	22954	43612	66763	105653
30	25	324	499	806	1169	1834	2858	4053	6783	11006	14931	28369	43427	68725
	20	431	664	1073	1555	2441	3803	5392	9025	14644	19866	37745	57782	91440
	15	495	762	1231	1785	2801	4365	6189	10358	16807	22800	43321	66317	104947
	0	559	861	1391	2017	3165	4932	6993	11705	18993	25765	48954	74940	118594
40	35	359	553	894	1296	2033	3168	4492	7518	12199	16550	31444	48135	76175
	30	484	745	1203	1745	2738	4266	6049	10124	16427	22285	42341	64817	102574
	25	563	867	1400	2029	3185	4962	7036	11776	19108	25922	49252	75396	119316
	3-0	679	1045	1688	2447	3840	5983	8483	14198	23039	31254	59382	90904	143857
50	45	391	602	972	1409	2211	3446	4886	8177	13268	18000	34200	52354	82851
	40	531	817	1319	1913	3002	4677	6632	11100	18011	24434	46424	71067	112465
	35	623	959	1548	2245	3523	5489	7783	13026	21136	28673	54479	83398	131979
	6-0	797	1227	1982	2873	4509	7025	9961	16672	27052	36698	69727	106740	168917
75	70	459	706	1141	1654	2596	4044	5734	9598	15573	21127	40141	61449	97243
	65	630	970	1567	2272	3566	5556	7877	13184	21393	29022	55142	84413	133585
	60	749	1153	1863	2701	4238	6604	9363	15671	25429	34497	65544	100336	158784
	15-0	1089	1677	2708	3926	6162	9601	13614	22785	36972	50156	95296	145882	230860
100	95	516	794	1283	1861	2920	4550	6451	10797	17519	23767	45157	69127	109394
	80	714	1099	1775	2573	4037	6291	8920	14929	24225	32863	62440	95584	151263
	85	854	1315	2124	3079	4832	7529	10676	17868	28994	39333	74732	114401	181042
	23-0	1377	2120	3424	4964	7790	12138	17211	28805	46740	63407	120474	184424	291854
125	120	567	872	1409	2042	3205	4994	7081	11852	19232	26090	49570	75883	120086
	115	787	1211	1956	2836	4450	6934	9832	16456	26703	36225	68827	105362	166736
	110	946	1456	2351	3409	5350	8335	11819	19781	32098	43543	82732	126649	200424
	90	1335	2055	3320	4814	7554	11771	16690	27933	45325	61488	116827	178842	283021
	31-0	1661	2556	4130	5987	9395	14639	20757	34741	56372	76473	145299	222428	351995
150	145	612	942	1522	2206	3462	5395	7649	12803	20774	28182	53545	81969	129717
	140	852	1312	2119	3072	4821	7512	10651	17827	28927	39241	74559	114136	180623
	135	1027	1581	2555	3704	5812	9056	12841	21492	34874	47309	89887	137602	217757
	110	1544	2377	3840	5568	8738	13614	19304	32309	52425	71119	135127	206856	327352
	40-0	1943	2992	4833	7006	10995	17131	24290	40655	65968	89491	170033	260291	411915
175	170	654	1006	1626	2357	3699	5763	8172	13677	22193	30107	57203	87567	138577
	165	912	1404	2268	3289	5161	8042	11403	19084	30967	42009	79818	122187	193363
	160	1102	1697	2741	3973	6236	9716	13776	23057	37414	50755	96434	147624	233618
	125	1819	2800	4524	6558	10292	16037	22739	38058	61754	83775	159173	243666	385605
	48-0	2223	3423	5529	8016	12580	19601	27793	46517	75480	102396	194552	297825	471312
200	195	692	1065	1721	2495	3915	6101	8650	14478	23493	31870	60553	92696	146694
	185	1170	1802	2911	4220	6622	10318	14630	24487	39733	53901	102413	156776	248100
	150	1957	3012	4866	7054	11070	17249	24458	40935	66422	90108	171205	262085	414753
	56-0	2500	3849	6217	9013	14145	22040	31251	52305	84722	115136	218758	334881	529954
250	245	762	1173	1895	2747	4312	6718	9526	15943	25870	35095	66681	102077	161538
	235	1295	1993	3220	4668	7326	11415	16185	27089	43955	59629	113295	173435	274463
	200	2203	3392	5479	7943	12466	19424	27541	46095	74796	101468	192789	295126	467041
	73-0	3050	4696	7585	10996	17257	26889	38127	63812	103544	140466	266886	408556	646545

Based on 10% (2 psi minimum) accuracy of regulation.

RATED STEAM CAPACITY TABLE

TYPE E5 MAIN VALVE - NORMAL PORT

Pounds of Saturated Steam per Hour

PRESSURE-psig		VALVE SIZE (inches)												
INLET	REDUCED	3/4	1	1-1/4	1-1/2	2	2-1/2	3	4	5	6	8	10	12
20	15	213	374	501	741	936	1310	2208	4490	6586	8532	13696	19646	35624
	10	279	490	656	969	1224	1713	2888	5875	8616	11162	17918	25702	46606
	0	331	580	777	1149	1451	2031	3423	6963	10212	13229	21236	30461	55237
25	10	229	402	538	796	1005	1406	2371	4822	7072	9161	14706	21095	38252
	15	303	531	712	1052	1328	1860	3135	6377	9352	12115	19448	27897	50587
	10	345	606	812	1199	1514	2120	3573	7268	10660	13809	22167	31797	57659
	0	379	665	892	1317	1663	2329	3926	7984	11710	15170	24352	34931	63341
30	25	244	427	573	846	1068	1496	2522	5129	7522	9745	15643	22438	40688
	20	325	570	764	1128	1425	1995	3362	6838	10030	12993	20857	29918	54251
	15	374	656	878	1298	1639	2295	3868	7867	11538	14948	23995	34419	62413
	0	426	748	1002	1480	1869	2616	4410	8970	13156	17044	27359	39245	71164
40	35	270	474	635	938	1184	1657	2794	5683	8335	10797	17332	24862	45083
	30	364	639	856	1265	1597	2236	3769	7665	11242	14563	23378	33534	60808
	25	424	744	997	1474	1861	2605	4392	8932	13101	16971	27243	39078	70862
	2-0	517	907	1215	1796	2267	3174	5351	10883	15961	20677	33192	47611	86335
50	45	294	515	690	1020	1287	1802	3038	6179	9063	11741	18847	27034	49022
	40	399	700	938	1386	1750	2450	4130	8399	12319	15959	25618	3674	66636
	35	469	823	1102	1629	2057	2879	4854	9872	14478	18756	30108	43188	78315
	5-0	607	1065	1427	2109	2662	3727	6283	12779	18743	24280	38976	55908	101381
75	70	344	604	810	1196	1510	2115	3565	7250	10633	13775	22113	31719	57517
	65	474	831	113	1645	2077	2908	4901	9969	14621	18941	30406	43614	79088
	60	563	988	1325	1957	2471	3460	5832	11862	17397	22537	36178	51894	94102
	13-0	829	1455	1950	2881	3638	5093	8585	17461	25609	33175	53255	76390	138521
100	95	387	680	911	1345	1699	2378	4009	8154	11960	15493	24871	35675	64691
	90	536	940	1260	1862	2351	3291	5548	11284	16549	21439	34415	49365	89516
	85	642	1126	1509	2230	2816	3942	6645	13515	19822	25679	41222	59129	107221
	20-0	1049	1840	2465	3642	4599	6439	10854	22075	32377	41943	67330	96580	175132
125	120	425	746	999	1477	1865	2610	4400	8950	13127	17005	27298	39157	71004
	115	591	1036	1389	2052	2591	3627	6114	12434	18237	23625	37925	54401	98646
	110	710	1246	1670	2468	3116	4362	7353	14956	21935	28416	45616	65432	118650
	90	1006	1765	2365	3494	4412	6177	10412	21177	31060	40236	64590	92650	168005
	28-0	1265	2219	2974	4394	5549	7768	13095	26633	39062	50602	81230	116519	211288
150	145	459	806	1079	1595	2014	2820	4753	9667	14178	18367	29484	42293	76692
	140	640	1122	1504	2222	2806	3928	6622	13468	19752	25588	41076	58920	106842
	135	772	1354	1814	2680	3384	4738	7987	16245	23826	3065	49547	71071	128875
	110	1163	2041	2735	4041	5102	7143	12041	24490	35919	46532	74696	107145	194290
	36-0	1480	2596	3479	5140	6490	9086	15317	31153	45692	59191	95018	136296	247150
175	170	491	861	1153	1704	2151	3012	5077	10327	15146	19621	31496	45179	81925
	165	685	1201	1610	2379	3003	4205	7088	14415	21143	27389	43967	63068	114363
	160	828	1452	1946	2875	3630	5082	8567	17424	25556	33106	53144	76232	138233
	125	1371	2405	3223	4762	6013	8418	14190	28861	42329	54835	88025	126266	228962
	44-0	1693	2971	3981	5882	7427	10397	17527	35647	52283	67730	108725	155958	282803
200	195	519	977	1221	1804	2277	3188	5374	10931	16032	20769	33339	47823	86719
	185	879	1542	2066	3053	3855	5396	9097	18502	27136	35153	56430	80945	146780
	150	1474	2585	3464	5119	6463	9048	15253	31023	45500	58943	94620	135725	246114
	52-0	1904	3340	4476	6614	8351	11691	19708	40084	58790	76160	122257	175369	318002
250	245	572	1003	1344	1986	2508	3511	5918	12036	17653	22869	36711	52659	95488
	235	972	1705	2285	3376	4263	5968	10061	20463	30012	38880	62412	89526	162340
	200	1658	2909	3898	5759	7272	10180	17161	34904	51192	66317	106456	152703	276902
	67-0	2323	4075	5460	8068	10187	14262	24042	48900	71720	92910	149145	213937	387939

Based on 10% (2 psi minimum) accuracy of regulation.

RATED WATER CAPACITY CHART

TYPE N6 DIFFERENTIAL PRESSURE VALVE

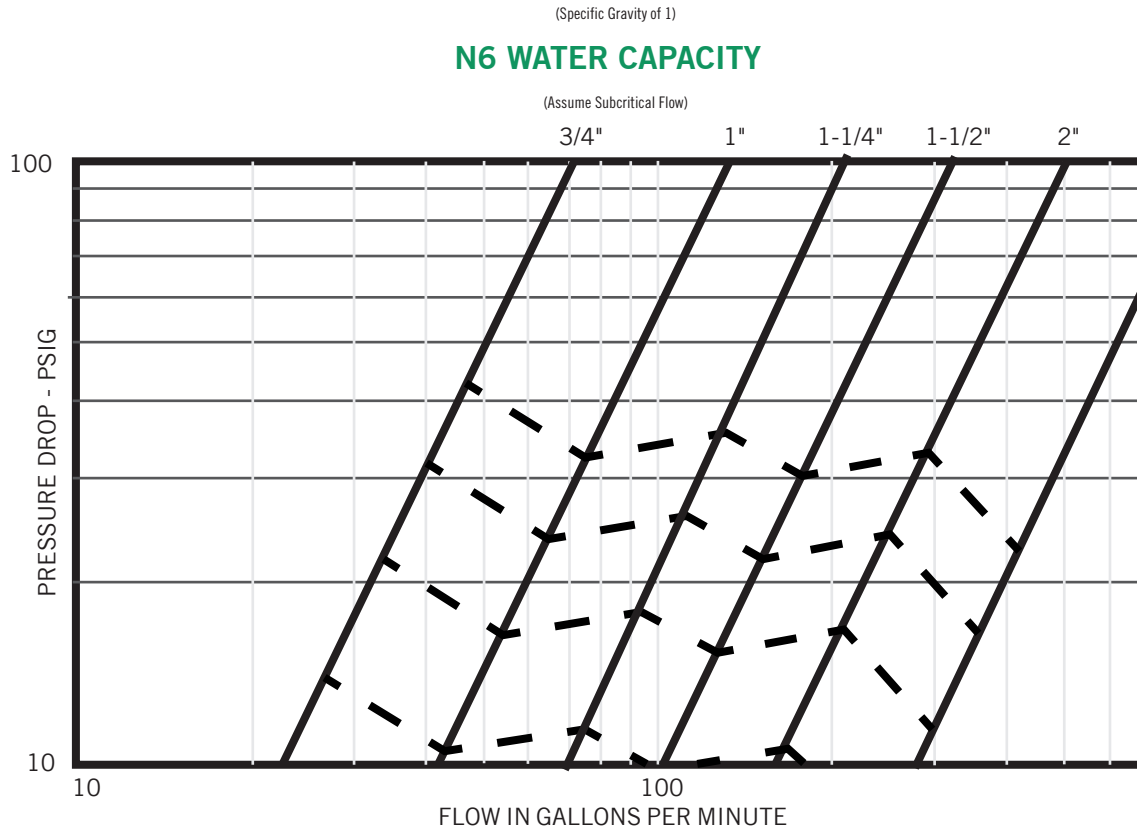

REG
SIZING

RATED WATER CAPACITY CHART

TYPE N6 DIFFERENTIAL PRESSURE VALVE

WATER IN GPM

PRESSURE DROP-psig	VALVE SIZE (inches)								
	1	1 1/4	1 1/2	2	2-1/2	3	4	5	6
5	7.4	17	23	32	48	71	116	188	263
10	10	24	33	45	68	101	164	266	373
15	13	29	40	55	84	124	201	325	457
20	15	33	47	64	97	143	233	376	528
30	18	41	51	79	118	175	285	460	646
50	23	53	74	102	153	226	368	594	834
75	29	65	90	125	187	277	450	727	1022
100	33	75	104	144	216	320	520	840	1180
125	37	84	116	161	241	358	581	939	1320
150	40	92	127	176	265	392	637	1029	1445
175	44	100	138	190	285	423	688	1111	1560

SIZING D50A DIRECT ACTING PRESSURE REGULATION

EXAMPLE 1 FOR CONDITIONS WITHIN CAPACITY TABLE.....

Given an initial steam pressure of 100 PSIG and a required flow of 500 #/hr. at a reduced pressure of 30 PSIG, determine droop, minimum controllable flow pressure and valve size.

In the Capacity Table opposite, the droop has been fixed at 25% of the maximum range of the adjusting spring. Therefore, for a 30 PSIG delivery pressure, a 25-80 adjusting spring would be selected. Thus, the droop is (25% x 80 = 20) 20 PSI.

Minimum controllable flow pressure = Reduced Pressure + Droop = 30 + 20 = 50 PSIG

Entering the Capacity Table at a minimum controllable flow pressure (OUT) of 50 PSIG, an initial pressure (IN) of 100 PSIG, the smallest valve size capable of delivering 500 #/hr. is the 1" size.

EXAMPLE 2 FOR CONDITIONS OUTSIDE CAPACITY TABLE.....

Given an initial steam pressure of 150 psig and a required flow of 900 #/hr. at a reduced pressure of 25 PSIG, determine the valve size, droop and minimum controllable flow pressure.

$$\frac{P1}{P2} = \frac{(25+14.7) \cdot 39.7}{(150+14.7) \cdot 164.7} = .24 \text{ thus } P2 = .24P1 < .58P1$$

Therefore, use Critical Flow Cv formula:

$$C_v = \frac{W}{1.71P1} = \frac{900}{1.71(150+14.7)} = \frac{900}{1.71(164.7)} = 3.2$$

Referring to the Cv line of the Capacity Table opposite, the 3/4" valve size ($C_v = 3.3$) is the smallest valve with the required capacity.

Droop is a function of valve size (3/4"), regulator capacity in percent [(3.2 ÷ 3.3) x 100 = 97%] and adjusting spring range (10-30). Enter the 3/4" Valve Droop Chart (below) at 97% and draw a line upward until you intersect the 10-30 curve. From there, draw a line left to the vertical axis. Droop in this case is 11 PSIG.

Minimum Controllable Flow Pressure = Reduced Pressure + Droop = 25 + 11 = 36 PSIG

Repeating the above procedure substituting a 1" valve size with a maximum Cv of 4.9, droop would be 8 PSIG and minimum controllable flow pressure would be 33 PSIG.

D50A RATED STEAM, AIR AND WATER CAPACITY TABLE

Steam Capacity Information (with PTFE seat)

Inlet pressure, psig	Outlet pressure, psig	Steam lbs per hour by size							
		1/4"	3/8"	1/2"	3/4"	1"	1 1/4"	1 1/2"	2"
25	15	25	38	88	126	202	302	353	567
	10	25	38	88	126	202	302	353	567
50	40	36	55	129	183	294	440	514	826
	25	42	63	137	210	336	504	588	945
75	10	42	63	137	210	336	504	588	945
	65	39	59	139	197	316	473	553	889
100	50	53	78	185	263	421	631	736	1184
	25	68	102	239	342	546	820	956	1537
125	10	69	102	239	342	546	820	956	1537
	90	49	91	154	231	371	560	654	1050
150	75	84	126	294	420	672	1008	1176	1890
	50	85	129	300	427	683	1025	1196	1922
200	25	85	129	300	427	683	1025	1196	1922
	100	88	133	266	441	706	1008	1165	1985
225	75	111	165	385	550	881	1320	1540	2477
	50	115	172	400	573	916	1375	1603	2577
250	25	115	172	400	573	916	1375	1603	2577
	140	63	95	126	210	350	525	616	994
300/400	125	112	168	392	560	896	1344	1568	2520
	100	116	174	405	578	924	1387	1618	2603
350/450	75	137	204	479	683	1093	1639	1912	3074
	50	137	204	479	683	1093	1639	1912	3074
400/500	150	130	195	454	648	1037	1555	1814	2916
	125	153	230	535	763	1221	1831	2136	3434
450/550	100	179	267	626	893	1429	2143	2500	4019
	75	179	267	626	893	1429	2143	2500	4019
500/600	150	190	287	671	956	1532	2297	2681	4308
	125	214	322	750	1072	1715	2572	3002	4823
550/650	100	230	344	804	1147	1835	2752	3212	5162
	75	230	344	804	1147	1835	2752	3212	5162
600/700	150	196	294	686	980	1568	2352	2744	4410
	125	253	379	888	1267	2027	3039	3546	5699
650/750	100	253	379	888	1267	2027	3039	3546	5699

Water Capacity Information

Inlet pressure, psig	Outlet pressure, psig	Gallons inlet per minute by size							
		1/4"	3/8"	1/2"	3/4"	1"	1 1/4"	1 1/2"	2"
25	15	0.6	1.0	2.6	4.0	5.7	9.2	10.4	16.0
	10	0.6	1.2	2.9	4.5	6.4	10.4	11.7	18.0
50	40	0.8	1.4	3.5	5.5	7.9	12.7	14.3	22.0
	25	0.8	1.6	3.8	6.0	8.6	13.8	15.6	24.0
75	10	0.8	1.6	3.8	6.0	8.6	13.8	15.6	24.0
	65	1.0	2.0	4.8	7.5	10.7	17.3	19.5	30.0
100	50	1.1	2.1	5.1	8.0	11.4	18.4	20.4	32.0
	25	1.3	2.3	5.8	9.0	12.9	20.7	23.4	36.0
125	10	1.3	2.3	5.8	9.0	12.9	20.7	23.4	36.0
	90	1.5	2.7	6.7	10.5	15.0	24.2	27.3	42.0
150	75	1.6	3.0	7.4	11.5	16.4	26.5	29.9	46.0
	50	1.7	3.2	8.0	12.5	17.9	28.8	32.5	50.0
200	25	1.8	3.4	8.3	13.0	18.6	29.9	33.8	52.0
	100	1.5	2.9	7.0	11.0	15.7	25.3	28.6	44.0
250	75	1.7	3.3	8.0	12.5	17.9	28.8	32.5	50.0
	50	2.0	3.6	9.0	14.0	20.0	32.2	36.4	56.0
300/400	25	2.0	3.6	9.0	14.0	20.0	32.2	36.4	56.0
	140	1.5	2.9	7.0	11.0	15.7	25.3	28.6	44.0
350/450	100	1.9	3.5	8.6	13.5	19.3	27.0	35.1	54.0
	75	2.0	3.8	9.3	14.5	20.7	33.4	37.7	58.0
400/500	50	2.2	4.0	9.9	15.5	22.2	35.7	40.3	62.0
	25	2.2	4.0	9.9	15.5	22.2	35.7	40.3	62.0
450/550	150	1.9	3.5	8.6	13.5	19.3	31.1	35.1	54.0
	100	2.2	4.0	9.9	15.5	22.2	35.7	40.3	62.0
500/600	75	2.5	4.6	11.2	17.5	25.0	40.3	45.5	70.0
	50	2.7	4.9	12.2	19.0	27.2	43.7	49.4	76.0
550/650	25	2.7	4.9	12.2	19.0	27.2	43.7	49.4	76.0
	150	2.1	3.9	9.6	15.0	21.5	34.5	39.0	60.0
600/700	100	2.5	4.6	11.2	17.5	25.0	40.3	45.5	70.0
	75	2.8	5.2	12.8	20.0	28.6	46.0	52.0	80.0
650/750	50	2.9	5.5	13.4	21.0	30.0	48.3	54.6	84.0
	25	2.9	5.5	13.4	21.0	30.0	48.3	54.6	84.0
700/800	150	2.5	4.6	11.2	17.5	25.0	40.3	45.5	70.0
	100	3.5	6.5	16.0	25.0	35.8	57.5	65.0	100.0
750/850	75	4.2	7.8	19.2	30.0	42.9	69.0	78.0	120.0
	50	4.2	7.8	19.2	30.0	42.9	69.0	78.0	120.0

REG SIZING

Air Capacity Information

Inlet pressure, psig	Outlet pressure, psig	Air capacity inlet in SCFM by size							
		1/4"	3/8"	1/2"	3/4"	1"	1 1/4"	1 1/2"	2"
25	15	4.7	7.0	16.5	23.5	37.6	56.4	65.8	105.8
	10	5.0	7.5	17.5	25.0	40.0	60.0	70.0	112.5
50	40	7.0	10.5	24.5	35.0	56.0	84.0	98.0	157.5
	25	8.2	12.3	28.7	41.0	65.6	98.4	114.8	184.5
75	10	8.2	12.3	28.7	41.0	65.6	98.4	114.8	184.5
	65	7.5	11.3	26.3	37.5	60.0	90.0	105.0	168.8
100	50	8.5	12.8	29.8	42.5	68.0	102.0	115.0	191.3
	25	11.0	16.5	38.5	55.0	88.0	132.0	154.0	247.5
125	10	11.0	16.5	38.5	55.0	88.0	132.0	154.0	247.5
	90	9.0	13.5	31.5	45.0	72.0	108.0	126.0	203.0
150	75	12.0	18.0	42.0	60.0	96.0	144.0	168.0	270.0
	50	15.0	22.5	52.5	75.0	120.0	180.0	210.0	337.5
200	25	15.0	22.5	52.5	75.0	120.0	180.0	210.0	337.5
	100	13.0	19.5	45.5	65.0	104.0	156.0	182.0	293.0
250	75	15.0	22.5	52.5	75.0	120.0	180.0	236.0	338.0
	50	18.0	27.0	63.0	90.0	144.0	216.0	252.0	405.0
300/400	25	18.0	27.0	63.0	90.0	144.0	216.0	252.0	405.0

Air Capacity Information

Inlet pressure, psig	Outlet pressure, psig	Air capacity inlet in SCFM by size							
		1/4"	3/8"	1/2"	3/4"	1"	1 1/4"	1 1/2"	2"
150	140	15.0	22.5	52.5	75.0	120.0	180.0	210.0	338.0
	100	18.0	27.0	63.0	90.0	144.0	216.0	252.0	405.0
	75	23.0	34.5	80.5	115.0	184.0	276.0	322.0	518.0
200	50	25.0	37.5	87.5	125.0	200.0	300.0	350.0	563.0
	25	25.0	37.5	87.5	125.0	200.0	300.0	350.0	563.0
	150	19.0	28.5	66.5	95.0	152.0	228.0	266.0	428.0
250	100	23.0	34.5	80.5	115.0	184.0	276.0	322.0	518.0
	75	27.0	40.5	94.5	135.0	216.0	324.0	378.0	608.0
	50	29.0	43.5	101.5	145.0	232.0	348.0	406.0	653.0
300/400	25	29.0	43.5	101.5	145.0	232.0	348.0	406.0	653.0
	150	25.0	37.5	87.5	125.0	200.0	300.0	350.0	563.0
	100	33.0	49.5	115.5	165.0	264.0	396.0	462.0	743.0
350/450	75	37.0	55.5	129.5	185.0	296.0	444.0	518.0	833.0
	50	37.0	55.5	129.5	185.0	296.0	444.0	518.0	833.0
	25	37.0	55.5	129.5	185.0	296.0	444.0	518.0	833.0
400/500	150	34.0	51.0	115.0	170.0	272.0	408.0	476.0	765.0
	100	37.0	55.5	129.5	185.0	296.0	444.0	518.0	833.0
	75	43.0	64.5	150.5	215.0	344.0	516.0	602.0	968.0
450/550	50	43.0	64.5	150.5	215.0	344.0	516.0	602.0	968.0

Capacities are based on a 20% droop.

SECTION II
CONTROL VALVES

SERIES K CONTROL VALVE



K1 CONTROL VALVE

APPLICATION DATA.....

- Process control systems for food, pulp and paper, chemical, petrochemical and other industries
- HVAC systems
- Feed water and fuel system controls in boiler rooms
- Packaged systems (OEM) such as heat exchangers, water purification systems and vaporizer, metal cleaning and plating
- Mixing or diverting applications

PLUG CHARACTERISTICS.....

Modified Equal Percent, 30: 1 flow range ability

SIZE 1/2" - 4" ANSI CLASS 125/250

- **Shutoff to 400 PSI without Positioner** for broad range of applications.
- **Ultra Compact Multi-spring Pneumatic Actuator** installs in tight spaces.
- **3-15 lb. Spring Ranges** in durable epoxy coated pneumatic actuators accommodate most standard input devices.
- **Powerful Electric Actuator** accepts a wide variety of signals while providing highest shutoff in it's class.
- **Live Loaded V ring Packing Assembly** is self adjusting.
- **Stainless Steel Valve Plugs and Seat Rings** resist wear and corrosion
- **Optional 3-Way** Body for mixing or diverting

MODELS.....

- Type K1 - Single Seat Bronze with union ends and Pneumatic Actuator
- Type K3 - 3-Way Bronze with union ends and Pneumatic Actuator
- Type K4 - Single Seat Flanged Cast Iron with Pneumatic Actuator
- Type K5 - Same as K1 with Electric Actuator, fail closed
- Type K6 - Same as K1 with Electric Actuator, fail open
- Type K7 - Same as K3 with Electric Actuator

OPTION.....

- 36 or 60 sq. in. Pneumatic Actuator
- Electric Actuator

APPLICABLE CODES

- Meets or exceeds ANSI B16.15 Class 250 or ANSI B16.1 Class 125
- ANSI/FCI 70-2 Class IV Seat Leakage

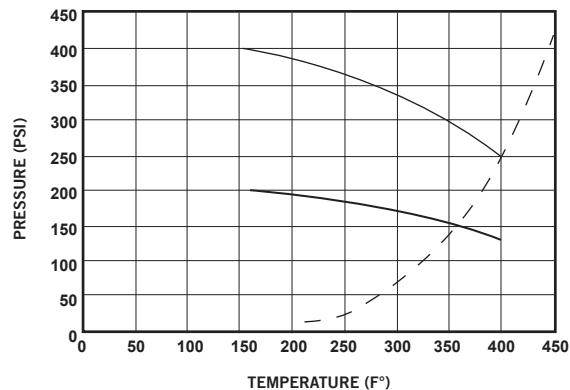

— ANSI/ASME B16.15 CLASS 250
 - - - ANSI/ASME B16.1 CLASS 125
 - · - · SATURATED STEAM

SERIES K CONTROL VALVE

APPLICATION DATA

Valve shall be pneumatically or electrically actuated, have a bronze or cast iron body and meet ANSI B16.15 Class 250 or ANSI B16.1 Class

125 accommodating pressures to 400 PSIG. Guiding shall be low friction utilizing spring loaded self adjusting chevron type Teflon packing, burnished stem and double guided stainless steel monolithic disc assembly. Valve trim shall be erosion resistant stainless steel with a modified equal percent flow characteristic capable of exceeding ANSI/FCI 70-2 Class IV shut off. Valve connections shall be female NPT with integral galvanized cast iron unions or flanged.

Pneumatic actuator shall be 36 sq. in. Or 60 sq. in and have a high Thrust multi spring diaphragm. Actuator components shall be stainless steel and epoxy coated. Fixed 3-15 pound springs shall be utilized to accommodate standard controller outputs without a positioner.

The electric actuator shall accept 0-10 VDC, 4-20 mA or 0-135 ohm Input signal. Spring shall return to initial position on loss of signal. Actuator shall have manual override. It shall close to 400 psi. Enclosure shall meet NEMA 1.

MATERIALS OF CONSTRUCTION

Body K1, K3, K5, K6, K7.....	Bronze ASTM 862
K4.....	Cast Iron ASTM A126 CL B
Bonnet K4.....	DI ASTM A536 65-45-12
Seat K1, K3, K5, K6, K7.....	303 SS ASTM A276
K4.....	420 SS ASTM A743
Plug/Stem Assy K1, K3, K5, K6, K7.....	303 SS ASTM A276
Plug K4.....	420 SS ASTM A743
Stem.....	303SS ASTM A582
Stem Guide - Body K1, K3, K5, K6, K7	301..... SS/Monel/Brass
Actuator Casing K1, K3, K4.....	Steel SAE 1006 - 1008/Epoxy
K5, K6, K7.....	Powder Coated Aluminum
Actuator Spring K1, K3, K4.....	Music Wire ASTM A228
Diaphragm K1, K3, K4.....	Nitrile/Polyester
Yoke K1, K3, K4.....	D Iron ASTM A536/Epoxy
K5, K6, K7.....	Powder Coated Aluminum

MAXIMUM RATED FLOW COEFFICIENTS* (CV)

VALVE	VALVE SIZE								
	1/2	3/4	1	1-1/4	1-1/2	2	2-1/2	3	4
2-WAY	5.2	7	11	20	25	30	71	94	146
3-WAY	5.4	6.4	8.7	19.5	24	34	--	--	--

K3, K7 DIMENSIONS INCHES (MM) AND WEIGHTS POUNDS (KG)

SIZE	A	B	C	D	WEIGHT	
					36 IN ²	60 IN ²
1/2-3/4 (15)-(20)	3-5/8 (92)	3-5/16 (84)	4-1/8 (105)	2-7/8 (73)	28 (13)	--
1 (25)	35/8 (92)	3-5/16 (84)	4-1/8 (105)	2-7/8 (73)	28 (13)	--
1-1/4 (32)	4-11/16 (119)	4-11/8 (105)	4-11/16 (119)	3-1/8 (79)	35 (16)	42 (22)
1-1/2 (40)	4-11/16 (119)	4-11/8 (105)	4-11/16 (119)	3-1/8 (79)	37 (17)	50 (23)
2 (50)	4-7/8 (124)	4-11/8 (106)	4-5/8 (125)	3-1/8 (79)	42 (19)	55 (25)

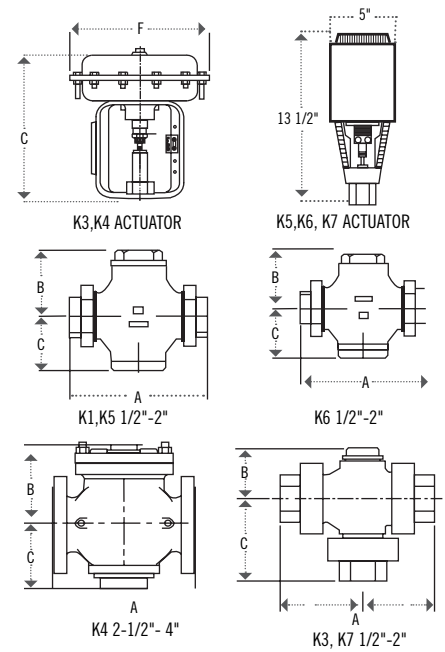

PNEUMATIC ACTUATOR DIMENSIONS INCHES (MM)

SIZE	E		F	
	39 IN ²	60 IN ²	36 IN ²	60 IN ²
1/2-3/4 (15)-(20)	9-7/8 (251)	--	9-1/4 (235)	--
1 (25)	9-7/8 (251)	11-3/4 (298)	9-1/4 (235)	11-1/4 (286)
1-1/4-1-1/2 (32)-(40)	9-7/8 (251)	11-3/4 (298)	9-1/4 (235)	11-1/4 (286)
2 (50)	9-7/8 (251)	11-3/4 (298)	9-1/4 (235)	11-1/4 (286)
2-1/2 (65)	--	11-3/4 (302)	--	11-1/4 (286)
3 (80)	--	11-3/4 (302)	--	11-1/4 (286)
4 (100)	--	11-3/4 (302)	--	11-1/4 (286)

K1, K4, K5 AND K6 DIMENSIONS, in. (mm) AND WEIGHTS, lbs (kg)

SIZE	B	B	C	WEIGHT		
				K1, K4 36IN ²	K1, K4 60IN ²	K5, K6
1/2-3/4 (15)-(20)	2-1/5 (50)	1-11/16 (43)	11/16 (30)	21 (9.5)	--	13 (6)
1 (25)	7-3/16 (183)	2-7/8 (73)	2-5/16 (58)	25-1/2 (11.6)	39 (17)	17-1/2 (8)
1-1/4 - 1-1/2 (32) - (40)	8-7/8 (226)	3-1/8 (79)	2-7/8 (74)	31-1/2 (14.3)	45 (20)	23-1/2 (11)
2 (50)	8-7/8 (226)	3-1/8 (79)	2-7/8 (74)	33-1/2 (15.3)	47 (21)	25-1/2 (12)
2-1/2 (80)	9-3/8 (238)	5-1/4 (133)	3-7/8 (118)	--	72 (33)	--
3 (80)	10 (238)	6-3/8 (155)	4-5/8 (136)	--	84 (39)	--
4 (100)	11-3/8 (302)	7-1/4 (181)	4-1/2 (187)	--	145 (66)	--

Control Tip: Pair with Airmaster Pneumatic Temperature Controller for local temperature control. SEE PAGE 64.

K1,K4,K5,K6 ACTUATOR SHUTOFF TABLE

(Refer to Temperature Limits)

Size	Orifice	Act.	Bench Range	Actuator Code	Reverse Shutoff, K1,K4*			Bench Range	Actuator Code	Direct Shutoff, K1,K4*			Shutoff, K5,K6
					3-15 psi	0-20 psi, ⁽¹⁾	0-30 psi, ⁽²⁾			3-15 psi	0-20 psi, ⁽¹⁾	0-30 psi, ⁽²⁾	
1/2	A,C,E	36	6-15	RA	400	-	-	3-12	DA	400	-	-	-
	B	36	6-15	RA	400	-	-	3-12	DA	300	-	-	-
								3-9	DB	400	-	-	-
T	36	6-15	RA	300	-	-	3-9	DB	400	-	-	-	
3/4	T	36	6-15	RA	100	-	-	3-9	DB	250	-	-	400
			9-15	RB	225	-	-						
			12-15	RC	300	-	-						
		60	12-15	RC	400	-	-	3-7	DG	400	-	-	
1	T	36	9-15	RB	150	-	-	3-9	DB	100	-	-	330
			12-15	RC	250	-	-						
			13-15	RE	400	-	-						
		60					3-7	DG	400	-	-		
1 1/4	T	36	9-15	RB	150	-	-	3-9	DR	150	-	-	210
			12-15	RC	200	-	-						
			13-15	RE	250	-	-						
		60	12-15	RG	0-300	-	-	3-7	DG	300	-	-	
			13-15	RH	400	-	-						
1 1/2	T	36	12-15	RC	150	-	-				-	-	161
			13-15	RE	200	-	-						
			60	12-15	RG	225	-	-	3-7	DG	200	-	
			13-15	RH	275	-	-						
2	T	36	12-15	RC	50	-	-						121
			13-15	RE	75	-	-						
		60	12-15	RG	125	-	-	3-7	DG	100	-	-	
			13-15	RH	175	-	-						
2 1/2	T	60	10-15	RH	75	100	100	3-8	DH	70	110	200	-
			12-15	RQ	125	125	125	3-8	DH	70	110	200	
			22-30	RT		125	125	3-8	DH	70	110	200	
3	T	60	10-15	RH	40	60	60	3-8	DH	40	60	100	-
			12-15	RQ	60	80	80	3-8	DH	40	60	100	
			22-30	RT		110	110	3-8	DH	40	60	100	
4	T	60	12-15	RQ	20	32	32	3-8	DH	10	15	25	-
			22-30	RT		50	50	3-8	DH	10	15	25	

CAUTION: K1 designed for 3-15 psi. Do not exceed 20 psi.

* Shutoff pressures are in conformance with ANSI/FCI 70-2 Class IV
Reverse Acting - Fail Closed/Air to Open (FC/ATO)

1 Based on 20 psi air supply with positioner.
2 Based on 30 psi air supply.

Direct Acting - Fail Open/Air to Close (FO/ATC)

K1, K4, K5, K6 CV TABLE

PERCENT OF TRAVEL			5	10	20	30	40	50	60	70	80	90	100
Valve Size	Travel	Orifice	Cv										
1/2	1/4	C	0.1	0.2	0.3	0.36	0.41	0.46	0.51	0.56	0.6	0.65	0.7
		E	0.3	0.5	0.7	0.9	1.1	1.3	1.5	1.7	1.9	2	2.1
		A	0.3	0.6	1.2	1.7	2.2	2.6	2.9	3.1	3.2	3.25	3.3
		B	0.15	0.25	0.65	1.5	2.7	3.3	3.7	3.9	4.1	4.2	4.3
		T	0.7	1.2	2.0	2.7	3.2	3.8	4.3	4.7	4.9	5.1	5.2
3/4	5/16	T	0.7	1.3	2.4	3.3	4.2	4.9	5.5	6.0	6.4	6.8	7.0
1	1/4	T	0.7	1.3	2.4	3.8	5.5	7.4	9.0	10.0	10.6	10.9	11.0
1-1/4	5/16	T	0.8	1.7	4.0	6.5	9.3	12.6	15.3	17.0	18.1	19.1	20.0
1-1/2	5/16	T	1.0	2.0	4.5	7.2	9.9	12.4	15.2	18.2	20.9	23.4	25.0
2	5/16	T	1.0	2.0	4.5	7.4	10.6	15.1	18.8	22.8	26.1	28.3	30.0
2-1/2	3/4	T	5	11	23	36	46	53	59	62.5	65.7	68	71
3	3/4	T	5	11	30	47	61	72	79	85	90	92	94
4	3/4	T	12	23	46	69	89	104	116	127	134	140	146

K3, K7 ACTUATOR SHUTOFF TABLE

SIZE	ACT SIZE	BENCH RANGE	ACTUATOR	K3 REVERSE SHUTOFF*		BENCH RANGE	ACTUATOR CODE	K3 DIRECT SHUTOFF*		K7 SHUTOFF
				3-15 PSI	0-20 PSI			3-15 PSI	0-20 PSI	
1/2	36	5.5 - 12.5	RA	125	300	4.5 - 13.5	DM	85	400	400
		6.5 - 11.5	RB	175	375	6 - 12	DA	175	400	
		8 - 11	RC	250	400	-	-	-	-	
3/4	36	5.5 - 12.5	RA	125	300	4.5 - 13.5	DM	85	400	400
		6.5 - 11.5	RB	175	375	6 - 12	DA	175	400	
		8 - 11	RC	250	400	-	-	-	-	
1	36	5.5 - 12.5	RA	75	200	4.5 - 13.5	DM	60	250	295
		6.5 - 11.5	RB	125	250	6 - 12	DA	125	300	
		8 - 11	RC	200	300	-	-	-	-	
1 1/4	36	5.5 - 12.5	RC	60	125	6 - 12	DC	80	200	185
		7.5 - 10.5	RE	110	200	7 - 11	DD	100	225	
	60	7.5 - 12	RG	200	300	7 - 11	DG	175	xx	
		8 - 11	RH	225	350	-	-	-	-	
1 1/2	36	5.5 - 12.5	RC	50	100	6 - 12	DC	60	150	145
		7.5 - 10.5	RE	85	150	7 - 11	DD	75	175	
	60	7.5 - 12	RG	125	250	7 - 11	DG	135	xx	
		8 - 11	RH	175	275	-	-	-	-	
2	36	5.5 - 12.5	RC	35	75	6 - 12	DC	45	100	105
		7.5 - 10.5	RE	70	100	7 - 11	DD	60	135	
	60	7.5 - 12	RG	75	175	7-11	DG	100	xx	
		8 - 11	RH	125	200	-	-	-	-	

* Lower Part (B) Fail Closed
 ** Upper Part (A) Fail Closed

K3, K7 CV TABLE

PERCENT OF TRAVEL			0	10	20	30	40	50	60	70	80	90	100
VALVE SIZE	TRAVEL (IN)	PORT	CV										
1/2	7/32	Lower	0	0.9	1.9	2.7	3.6	4.3	4.8	5.2	5.3	5.35	5.4
		Upper	5.6	5.55	5.5	5.3	4.9	4.5	3.9	3.1	2.2	1.2	0
3/4	7/32	Lower	0	0.9	2	3	4	4.9	5.5	6	6.2	6.3	6.4
		Upper	7.1	7	6.9	6.5	5.9	5.2	4.4	3.4	2.3	1.2	0
1	7/32	Lower	0	0.8	1.7	2.9	4	5.3	6.2	7.2	7.8	8.4	8.7
		Upper	9.2	8.5	7.9	7.1	6.2	5.3	4.2	3.2	2.1	1.1	0
1-1/4	1/2	Lower	0	2.7	6.2	10.2	15	18.8	20	20.8	21.2	21.6	22
		Upper	19.5	19	18.5	17.5	15.5	13.5	11	8	5	2.5	0
1-1/2	1/2	Lower	0	2	6	11	16	20	22.5	24.5	26	27	28
		Upper	24	23	22	20	18	15	12	9	6	2.7	0
2	1/2	Lower	0	2.2	5.7	10.9	16	21	24	27.4	30	32	34
		Upper	35	32.4	30	27	23.5	20	16	12	8	4	0

K3, K7 OPERATION

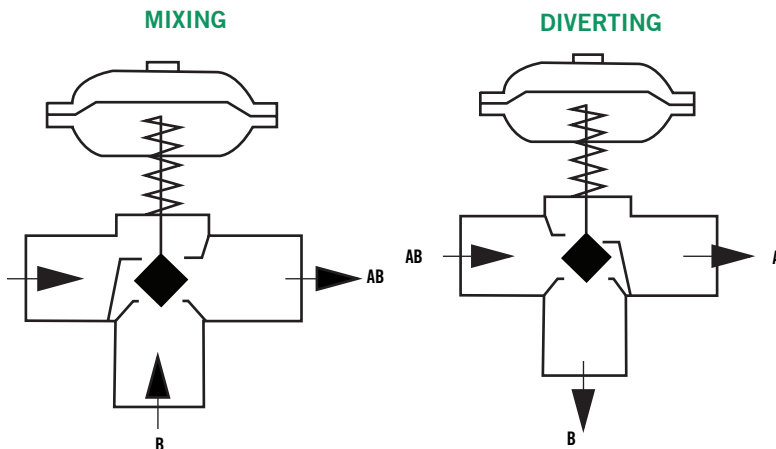

When used for mixing service, the forces developed by the two inlet flows oppose each other, creating little, if any, unbalance. Thus, the actuator can control the flow efficiently with very little power lost in overcoming dynamic unbalance.

When used for diverting service, simply reverse the valve installation

K1, K4, K5, K6

SATURATED STEAM CAPACITY TABLE

(Modified Equal Percent Contour Plug) (Lb/Hr)

Steam Capacity Table

Pressure (PSI)		Valve Size and Port												
P1	P2	1/2"C	1/2"E	1/2"A	1/2"B	1/2"T	3/4"	1"	1-1/4"	1-1/2"	2"	2-1/2"	3"	4"
10	5	22	65	102	133	161	217	341	620	775	930	2237	2962	4601
	0	27	81	128	166	201	270	425	773	966	1159	2846	3768	5853
15	10	24	72	114	148	179	241	379	689	861	1033	2477	3280	5094
	5	31	92	145	189	229	308	484	880	1099	1319	3216	4257	6613
20	0	34	101	159	207	250	337	529	962	1202	1443	3586	4748	7374
	15	26	79	124	161	195	262	412	750	937	1125	2692	3565	5537
	10	34	102	161	209	253	341	536	974	1217	1461	3543	4691	7286
30	0	40	119	187	243	294	396	623	1132	1416	1699	4262	5643	8765
	25	30	90	142	184	223	300	472	858	1072	1287	3072	4067	6316
	15	46	137	215	280	338	455	715	1301	1626	1951	4755	6295	9778
40	0	51	152	239	312	377	507	797	1450	1812	2174	5525	7315	11362
	25	52	156	245	319	385	519	815	1482	1852	2223	5384	7128	11071
	15	59	178	280	365	442	595	935	1699	2124	2549	6297	8337	12948
50	0	62	185	290	378	457	615	967	1758	2198	2637	6724	8903	13827
	35	57	172	271	353	427	575	903	1643	2053	2464	5943	7869	12222
	30	63	190	299	389	470	633	995	1809	2262	2714	6596	8732	13563
	25	67	202	318	414	501	674	1059	1925	2406	2888	7076	9368	14550
60	2-0	72	217	341	444	537	723	1136	2066	2582	3099	7905	10466	16256
	45	63	188	295	384	464	625	982	1786	2232	2679	6444	8531	13250
	40	69	208	327	426	515	693	1090	1981	2477	2972	7194	9524	14792
	35	74	223	351	457	552	744	1169	2125	2656	3187	7767	10282	15971
	4-0	83	249	391	509	616	829	1303	2370	2962	3555	9067	12005	18645
75	55	77	232	365	476	575	774	1216	2212	2765	3318	7996	10587	16443
	50	84	251	395	514	622	837	1315	2391	2989	3587	8690	11505	17870
	45	89	266	417	544	658	885	1391	2530	3162	3795	9246	12241	19013
	8-0	99	296	466	607	734	988	1552	2822	3527	4233	10797	14294	22202
100	75	97	291	457	596	721	970	1525	2773	3466	4159	10020	13266	20604
	60	113	340	534	696	841	1133	1780	3236	4045	4854	11845	15683	24358
	15-0	125	375	589	767	927	1249	1962	3567	4459	5351	13649	18071	28068
125	100	109	326	512	667	806	1086	1706	3102	3877	4652	11169	14787	22968
	75	138	413	649	845	1022	1376	2163	3933	4916	5899	14409	19077	29630
	21-0	151	452	710	925	1119	1507	2367	4304	5381	6457	16470	21806	33869
150	125	119	356	560	730	882	1188	1866	3394	4242	5090	12192	16142	25071
	100	153	460	723	943	1140	1535	2412	4385	5481	6577	15975	21150	32850
	28-0	176	529	831	1082	1309	1762	2769	5035	6293	7552	19264	25505	39614
175	150	128	384	604	787	951	1281	2013	3659	4574	5489	13124	17376	26988
	125	168	503	791	1030	1246	1677	2635	4791	5989	7187	17388	23021	35755
	100	189	567	891	1161	1403	1889	2969	5398	6747	8097	19859	26293	40838
	35-0	202	605	951	1239	1498	2016	3168	5761	7201	8641	22031	29168	45304
200	150	181	542	852	1110	1342	1806	2839	5161	6452	7742	18677	24728	38407
	125	206	618	971	1265	1529	2059	3235	5882	7353	8823	21533	28509	44279
	41-0	227	681	1069	1393	1685	2268	3565	6481	8101	9722	24799	32833	50996
225	175	193	578	908	1183	1430	1925	3025	5500	6875	8250	-	-	-
	150	221	664	1043	1359	1644	2213	3478	6323	7904	9485	-	-	-
	48-0	252	755	1187	1547	1870	2518	3956	7194	8992	10790	-	-	-
250	200	204	611	960	1251	1512	2036	3199	5817	7271	8725	-	-	-
	150	256	769	1208	1574	1904	2563	4027	7322	9153	10984	-	-	-
	100	275	825	1297	1690	2044	2752	4324	7862	9827	11792	-	-	-
	54-0	277	830	1304	1699	2055	2766	4346	7902	9878	11854	-	-	-

CONTROL VALVES

- It is recommended to keep valve outlet velocity below 30,000 ft./min.
- Capacities based on maximum Cv

K1, K4, K5, K6 SATURATED STEAM CAPACITY TABLE

(MODIFIED EQUAL PERCENT CONTOUR PLUG) (KG/HR)

Pressure (BAR)		Valve Size and Port												
P1	P2	1/2"C	1/2"E	1/2"A	1/2"B	1/2"T	3/4"	1"	1-1/4"	1-1/2"	2"	2-1/2"	3"	4"
0.7	0.3	10	31	49	64	78	104	164	298	373	447	1079	1429	2220
	0.2	11	34	53	69	84	113	177	322	402	483	1171	1551	2409
1	0.7	10	31	48	63	76	102	161	292	365	438	1049	1389	2157
	0.5	12	37	59	76	92	125	196	356	445	534	1289	1707	2651
	0.3	14	42	65	85	103	139	218	396	495	594	1448	1918	2978
1.5	1	14	43	67	87	106	142	224	407	508	610	1467	1942	3017
	0.7	17	50	79	103	124	167	263	479	598	718	1746	2312	3591
	0.5	18	53	84	109	132	178	280	508	635	762	1870	2476	3846
2	1.5	16	47	74	97	117	157	247	449	562	674	1616	2139	3323
	1.2	19	56	88	115	139	188	295	536	670	804	1945	2575	3999
	1	20	60	95	124	149	201	316	575	719	862	2100	2781	4319
3	2	24	73	114	149	180	242	381	692	865	1038	2508	3321	5158
	1.0	29	87	137	179	216	291	457	832	1040	1248	3098	4102	6371
	0	32	97	152	198	239	322	506	920	1149	1379	3264	4322	6713
3.5	3.0	20	59	92	120	145	195	307	558	698	838	2000	2647	4112
	2.0	30	89	140	182	221	297	466	848	1060	1272	3099	4103	6373
	1.0	33	99	155	202	245	329	518	941	1176	1412	3531	4675	7261
	.1-0	36	108	170	222	268	361	567	1031	1289	1547	3661	4847	7528
4	3.0	28	83	130	169	204	275	432	786	983	1179	2836	3755	5832
	2.0	34	103	162	211	255	344	540	982	1228	1473	3615	4786	7433
	1.0	37	110	172	224	271	365	574	1044	1305	1566	3942	5219	8105
	.3-0	39	118	186	242	293	394	620	1126	1408	1690	4000	5296	8225
5	4.0	30	91	144	187	226	305	479	870	1088	1306	3131	4145	6438
	3.0	39	117	184	239	290	390	612	1113	1392	1670	4069	5387	8367
	2.0	43	128	201	262	317	427	671	1220	1525	1830	4544	6016	9344
	.6-0	47	140	220	287	347	467	734	1334	1667	2001	4757	6299	9783
7	5.0	47	140	221	288	348	468	736	1338	1672	2007	4848	6419	9970
	3.0	56	169	265	346	418	563	884	1607	2009	2411	5987	7926	12311
	1.0-0	62	187	293	382	462	622	978	1778	2222	2667	6311	8356	12978
9	7.0	53	160	252	328	397	534	839	1526	1907	2289	5505	7289	11321
	5.0	67	200	314	410	496	667	1048	1906	2382	2859	7015	9288	14425
	1.6-0	77	230	361	470	569	765	1203	2187	2733	3280	7762	10277	15962
10	8.0	56	168	265	345	417	562	882	1605	2006	2407	5780	7652	11885
	5.0	75	224	353	459	556	748	1175	2137	2671	3205	7916	10480	16277
	1.8-0	84	251	395	515	623	838	1317	2395	2994	3592	8502	11256	17483
12	10.0	62	185	291	379	458	616	968	1761	2201	2641	6327	8376	13009
	7.0	85	254	399	520	629	846	1330	2418	3023	3627	8886	11764	18272
	5.0	90	270	425	553	669	900	1415	2573	3216	3859	9633	12753	19808
	2.4-0	98	294	462	602	728	979	1539	2798	3498	4197	9939	13158	20438
14	10.0	87	261	410	535	647	871	1368	2488	3110	3732	-	-	-
	5.0	104	312	491	640	774	1041	1636	2975	3719	4463	-	-	-
	2.9-0	112	337	530	691	835	1124	1767	3213	4016	4819	-	-	-
15	12.0	81	243	383	499	603	812	1275	2319	2898	3478	-	-	-
	5.0	111	332	521	679	821	1105	1737	3158	3948	4737	-	-	-
	3.1-0	120	359	564	734	888	1195	1878	3415	4269	5123	-	-	-
17	15.0	73	219	344	448	542	730	1147	2086	2607	3129	-	-	-
	10.0	115	346	544	709	858	1155	1815	3300	4125	4950	-	-	-
	5.0	127	380	597	778	941	1266	1990	3619	4523	5428	-	-	-
	3.7-0	133	400	629	819	990	1333	2095	3809	4762	5714	-	-	-

- It is recommended to keep valve outlet velocity below 30,000 ft./min.
- Capacities based on maximum Cv

K1, K4, K5, K6 SATURATED WATER CAPACITY TABLE

(MODIFIED EQUAL PERCENT CONTOUR PLUG) (KG/HR)

Pressure (PSI)		Valve Size and Port												
P1	P2	1/2"C	1/2"E	1/2"A	1/2"B	1/2"T	3/4"	1"	1-1/4"	1-1/2"	2"	2-1/2"	3"	4"
10	5	2	5	7	10	12	16	25	45	56	67	159	210	326
	3	2	6	9	11	14	19	29	53	66	79	188	249	386
15	10	2	5	7	10	12	16	25	45	56	67	159	210	326
	7	2	6	9	12	15	20	31	57	71	85	201	266	413
	4	2	7	11	14	17	23	36	66	83	99	235	312	484
20	15	2	5	7	10	12	16	25	45	56	67	159	210	326
	10	2	7	10	14	16	22	35	63	79	95	225	297	462
	5	3	8	13	17	20	27	43	77	97	116	275	364	565
30	22	2	6	9	12	15	20	31	57	71	85	201	266	413
	17	3	8	12	16	19	25	40	72	90	108	256	339	526
	6	3	10	16	21	25	34	54	98	122	147	348	461	715
40	25	3	8	13	17	20	27	43	77	97	116	275	364	565
	20	3	9	15	19	23	31	49	89	112	134	318	420	653
	8	4	12	19	24	29	40	62	113	141	170	402	532	826
50	35	3	8	13	17	20	27	43	77	97	116	275	364	565
	30	3	9	15	19	23	31	49	89	112	134	318	420	653
	25	4	11	17	22	26	35	55	100	125	150	355	470	730
	10	4	13	21	27	33	44	70	126	158	190	449	595	923
60	50	2	7	10	14	16	22	35	63	79	95	225	297	462
	40	3	9	15	19	23	31	49	89	112	134	318	420	653
	25	4	12	20	25	31	41	65	118	148	177	420	556	864
	12	5	15	23	30	36	48	76	139	173	208	492	651	1012
75	70	2	5	7	10	12	16	25	45	56	67	159	210	326
	50	4	11	17	22	26	35	55	100	125	150	355	470	730
	25	5	15	23	30	37	49	78	141	177	212	502	665	1032
	15	5	16	26	33	40	54	85	155	194	232	550	728	1131
100	75	4	11	17	22	26	35	55	100	125	150	355	470	730
	60	4	13	21	27	33	44	70	126	158	190	449	595	923
	20	6	19	30	38	47	63	98	179	224	268	635	841	1306
125	100	4	11	17	22	26	35	55	100	125	150	355	470	730
	75	5	15	23	30	37	49	78	141	177	212	502	665	1032
	24	7	21	33	43	52	70	111	201	251	301	714	945	1467
150	125	4	11	17	22	26	35	55	100	125	150	355	470	730
	100	5	15	23	30	37	49	78	141	177	212	502	665	1032
	29	8	23	36	47	57	77	121	220	275	330	781	1034	1606
175	150	4	11	17	22	26	35	55	100	125	150	355	470	730
	125	5	15	23	30	37	49	78	141	177	212	502	665	1032
	100	6	18	29	37	45	61	95	173	217	260	615	814	1264
	34	8	25	39	51	62	83	131	237	297	356	843	1116	1734
200	150	5	15	23	30	37	49	78	141	177	212	502	665	1032
	100	7	21	33	43	52	70	110	200	250	300	710	940	1460
	39	9	27	42	55	66	89	140	254	317	381	901	1193	1853
225	175	5	15	23	30	37	49	78	141	177	212	-	-	-
	100	8	23	37	48	58	78	123	224	280	335	-	-	-
	43	9	28	45	58	70	94	148	270	337	405	-	-	-
250	200	5	15	23	30	37	49	78	141	177	212	-	-	-
	150	7	21	33	43	52	70	110	200	250	300	-	-	-
	100	9	26	40	53	64	86	135	245	306	367	-	-	-
300	48	10	30	47	61	74	99	156	284	355	426	-	-	-
	250	5	15	23	30	37	49	78	141	177	212	-	-	-
	150	9	26	40	53	64	86	135	245	306	367	-	-	-
	58	11	33	51	67	81	109	171	311	389	467	-	-	-
400	350	5	15	23	30	37	49	78	141	177	212	-	-	-
	200	10	30	47	61	74	99	156	283	354	424	-	-	-
	77	13	38	59	77	93	126	198	359	449	539	-	-	-

CONTROL VALVES

- It is recommended to keep valve outlet velocity below 30,000 ft./min.
- Capacities based on maximum Cv

K1, K4, K5, K6 SATURATED STEAM CAPACITY TABLE

(MODIFIED EQUAL PERCENT CONTOUR PLUG) (KG/HR)

Pressure (BAR)		Valve Size and Port												
P1	P2	1/2"C	1/2"E	1/2"A	1/2"B	1/2"T	3/4"	1"	1-1/4"	1-1/2"	2"	2-1/2"	3"	4"
0.7	0.3	0.4	1.1	1.8	2.4	2.8	3.8	6.0	10.9	13.7	16.4	38.8	51.4	79.9
	0.2	0.4	1.3	2.0	2.6	3.2	4.3	6.7	12.2	15.3	18.3	43.4	57.5	89.3
1	0.7	0.3	1.0	1.6	2.0	2.5	3.3	5.2	9.5	11.8	14.2	33.6	44.5	69.2
	0.5	0.4	1.3	2.0	2.6	3.2	4.3	6.7	12.2	15.3	18.3	43.4	57.5	89.3
1.5	0.25	0.5	1.6	2.5	3.2	3.9	5.2	8.2	15.0	18.7	22.5	53.2	70.4	109.3
	1	0.4	1.3	2.0	2.6	3.2	4.3	6.7	12.2	15.3	18.3	43.4	57.5	89.3
	0.7	0.5	1.6	2.6	3.3	4.0	5.4	8.5	15.5	19.3	23.2	54.9	72.7	112.9
2	0.3	0.7	2.0	3.1	4.1	4.9	6.6	10.4	18.9	23.7	28.4	67.3	89.0	138.3
	1.5	0.4	1.3	2.0	2.6	3.2	4.3	6.7	12.2	15.3	18.3	43.4	57.5	89.3
3	1	0.6	1.8	2.9	3.7	4.5	6.1	9.5	17.3	21.6	25.9	61.4	81.3	126.3
	0.4	0.8	2.3	3.6	4.7	5.7	7.7	12.0	21.9	27.3	32.8	77.7	102.8	159.7
3.5	2	0.6	1.8	2.9	3.7	4.5	6.1	9.5	17.3	21.6	25.9	61.4	81.3	126.3
	1.5	0.7	2.2	3.5	4.6	5.5	7.4	11.7	21.2	26.5	31.8	75.2	99.6	154.6
4	0.6	0.9	2.8	4.4	5.8	7.0	9.4	14.7	26.8	33.5	40.2	95.1	125.9	195.6
	3	0.4	1.3	2.0	2.6	3.2	4.3	6.7	12.2	15.3	18.3	43.4	57.5	89.3
	2	0.7	2.2	3.5	4.6	5.5	7.4	11.7	21.2	26.5	31.8	75.2	99.6	154.6
4.5	1.5	0.9	2.6	4.0	5.3	6.4	8.6	13.5	24.5	30.6	36.7	86.8	115.0	178.6
	0.7	1.0	3.0	4.8	6.2	7.5	10.1	15.9	28.9	36.2	43.4	102.7	136.0	211.3
	3.5	0.4	1.3	2.0	2.6	3.2	4.3	6.7	12.2	15.3	18.3	43.4	57.5	89.3
5	3	0.7	2.2	2.9	3.7	4.5	6.1	9.5	17.3	21.6	25.9	61.4	81.3	126.3
	2	0.9	2.6	4.0	5.3	6.4	8.6	13.5	24.5	30.6	36.7	86.8	115.0	178.6
	0.8	1.1	3.0	5.1	6.7	8.0	10.8	17.0	30.9	38.7	46.4	109.8	145.4	225.9
6	4	0.6	1.3	2.9	3.7	4.5	6.1	9.5	17.3	21.6	25.9	61.4	81.3	126.3
	3	0.9	1.8	4.0	5.3	6.4	8.6	13.5	24.5	30.6	36.7	86.8	115.0	178.6
	2	1.0	2.6	4.9	6.4	7.8	10.5	16.5	30.0	37.4	44.9	106.3	140.8	218.7
7	1	1.2	3.6	5.7	7.4	9.0	12.1	19.0	34.6	43.2	51.9	122.8	162.6	252.5
	5	0.6	1.8	2.9	3.7	4.5	6.1	9.5	17.3	21.6	25.9	61.4	81.3	126.3
	3	1.0	3.1	4.9	6.4	7.8	10.5	16.5	30.0	37.4	44.9	106.3	140.8	218.7
8	1.2	1.3	4.0	6.3	8.1	9.9	13.3	20.8	37.9	47.4	56.8	134.5	178.1	276.6
	6	0.9	2.6	4.0	5.3	6.4	8.6	13.5	24.5	30.6	36.7	86.8	115.0	178.6
	5	1.0	3.1	4.9	6.4	7.8	10.5	16.5	30.0	37.4	44.9	106.3	140.8	218.7
9	1.6	1.5	4.6	7.2	9.4	11.4	15.3	24.1	43.8	54.7	65.6	155.3	205.6	319.4
	8	0.9	2.6	4.0	5.3	6.4	8.6	13.5	24.5	30.6	36.7	86.8	115.0	178.6
	5	1.4	4.1	6.4	8.3	10.1	13.5	21.3	38.7	48.3	58.0	137.3	181.8	282.3
10	2	1.7	5.1	8.1	10.5	12.7	17.1	26.9	48.9	61.1	73.4	173.7	229.9	357.1
	10	0.9	2.6	4.0	5.3	6.4	8.6	13.5	24.5	30.6	36.7	86.8	115.0	178.6
	8	1.2	3.6	5.7	7.4	9.0	12.1	19.0	34.6	43.2	51.9	122.8	162.6	252.5
11	5	1.6	4.8	7.6	9.8	11.9	16.0	25.2	45.8	57.2	68.6	162.4	215.1	334.0
	2.3	1.9	5.7	8.9	11.6	14.0	18.9	29.6	53.9	67.3	80.8	191.2	253.2	393.2
	10	1.2	3.6	5.7	7.4	9.0	12.1	19.0	34.6	43.2	51.9	-	-	-
12	5	1.8	5.4	8.6	11.2	13.5	18.2	28.5	51.9	64.9	77.8	-	-	-
	2.7	2.0	6.1	9.6	12.5	15.1	20.3	32.0	58.1	72.7	87.2	-	-	-
	12	1.0	3.1	4.9	6.4	7.8	10.5	16.5	30.0	37.4	44.9	-	-	-
13	5	1.9	5.7	9.0	11.8	14.2	19.1	30.1	54.7	68.4	82.0	-	-	-
	2.9	2.1	6.3	9.9	12.9	15.6	21.1	33.1	60.2	75.2	90.2	-	-	-
	14	1.0	3.1	4.9	6.4	7.8	10.5	16.5	30.0	37.4	44.9	-	-	-
14	10	1.6	4.8	7.6	9.8	11.9	16.0	25.2	45.8	57.2	68.6	-	-	-
	5	2.1	6.3	9.9	12.9	15.6	21.0	33.0	59.9	74.9	89.9	-	-	-
	3.2	2.2	6.7	10.6	13.8	16.7	22.5	35.3	64.2	80.3	96.4	-	-	-
15	17	1.0	3.1	4.9	6.4	7.8	10.5	16.5	30.0	37.4	44.9	-	-	-
	14	1.5	4.4	7.0	9.1	11.0	14.8	23.3	42.4	53.0	63.5	-	-	-
	3.9	2.4	7.3	11.5	14.9	18.0	24.3	38.2	69.4	86.7	104.1	-	-	-
16	24	1.0	3.1	4.9	6.4	7.8	10.5	16.5	30.0	37.4	44.9	-	-	-
	20	1.6	4.8	7.6	9.8	11.9	16.0	25.2	45.8	57.2	68.6	-	-	-
	5.2	2.8	8.5	13.3	17.4	21.0	28.3	44.4	80.8	100.9	121.1	-	-	-

- It is recommended to keep valve outlet velocity below 30,000 ft./min.
- Capacities based on maximum Cv.

TYPE J CONTROL VALVE

APPLICATIONS

- Process control systems for food, pulp and paper, chemical, petrochemical and other industries
- HVAC systems
- Feed water and fuel system controls in boiler rooms
- Packaged systems (OEM) such as heat exchangers, water purification systems and vaporizer, metal cleaning and plating

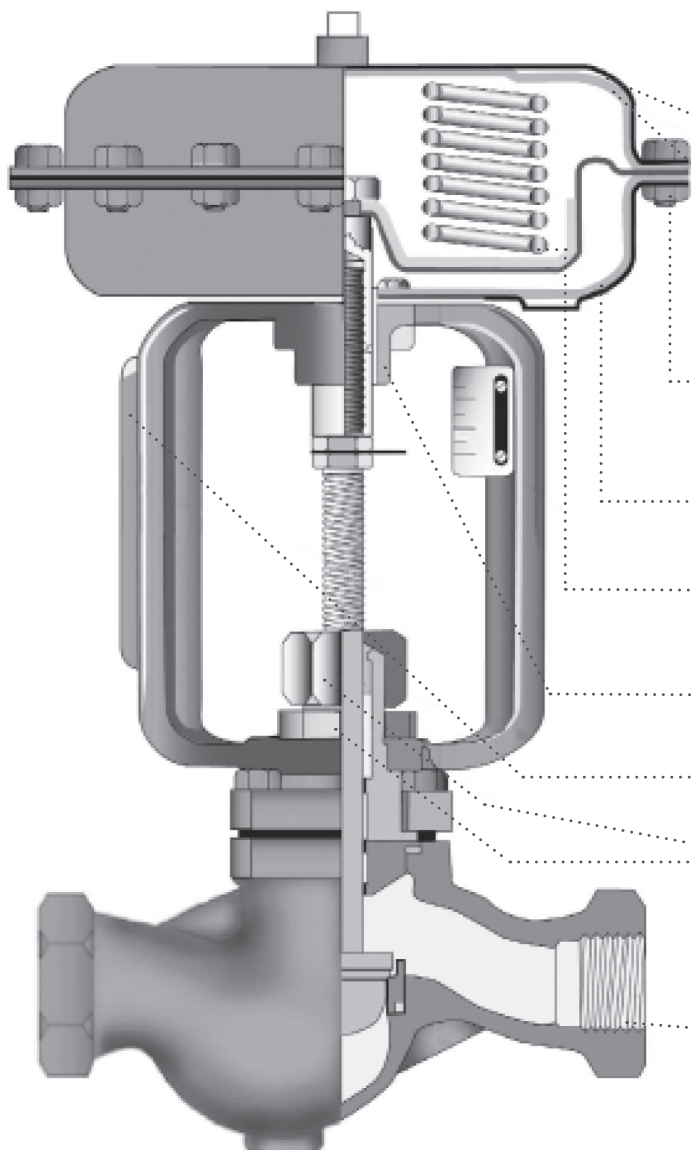

Pressures to 1440 PSIG Temperatures to 600°F

High-thrust, Compact Actuator

Offers the muscle required to positively position the plug in response to control signal

36 and 60 Inch Actuator

Sizes match different operating conditions

Bolted Diaphragm Joint

For maximum strength, ease of maintenance and high-pressure tightness

Molded, Reinforced Rolling Diaphragm

Provides dependable, accurate control

Corrosion-protected Multiple Springs

For lower hysteresis and positive shutoff with 3-15 psi signal

Low-friction Actuator Stem Guiding

For accurate repetitive positioning

Mounting Pad NEMUR 4 Compliant

Drilled and tapped for accessories

Super finished Stem

Reduces friction, extends packing life

High Performance, Low Friction Packing

Selections to meet your system requirements

High-capacity Streamlined Body

Minimizes turbulence and pressure drop

TYPE J CONTROL VALVE



SIZES 1/2" - 2"
ANSI CLASS 150, 300, 600

- **High Capacity Streamlined Body** reduces velocity and pressure loss.
- **Compact Design** for ease of installation.
- **Multiple Port Sizes** allows flexibility in sizing.
- **Stainless Steel Trim** for long life and corrosion resistance.
- **Super Polished, Extra Thick Stem** provides low friction and precise control.
- **Live Loaded V ring Packing** is self adjusting.
- **Slip-on Flanges** for flexibility in piping.
- **NEMUR 4 Mounting Pad** for accessories.

MODELS

- J1 — Cast Iron
- J3 — Stainless Steel*

OPTIONS

- 36 or 60 sq. in. actuators
- Soft Seats- 450° F
- Moore, PMV, Eckardt Accessories
- Threaded or Flanged Connections
- Graphite or High Temperature Packing
- High Temperature 600°F

APPLICABLE CODES

- ANSI/ISA 70-2 Class IV and VI seat leakage
- NEMUR 4 mounting of accessories

PLUG CHARACTERISTICS

- 1/8" to 1/4" Port Sizes - Equal Percent, 50:1 flow rangeability
- 5/8" to 2-1/4" Port Sizes - Modified Equal Percent, 100:1 flow rangeability

Canadian Registration # OC 0591.9C

"Cv Valves"				
1/2	3/4	1	1 1/2	2
5.1	10.3	18.3	37	67

* Body is ANSI Class 600. Pressure rating may be limited by choice of flanges.

- Process control systems for food, pulp and paper, chemical, petrochemical and other industries
- HVAC systems
- Feed water and fuel system controls in boiler rooms
- Packaged systems (OEM) such as heat exchangers, water purification systems and vaporizer, metal cleaning and plating

PRESSURE/TEMPERATURE CHART

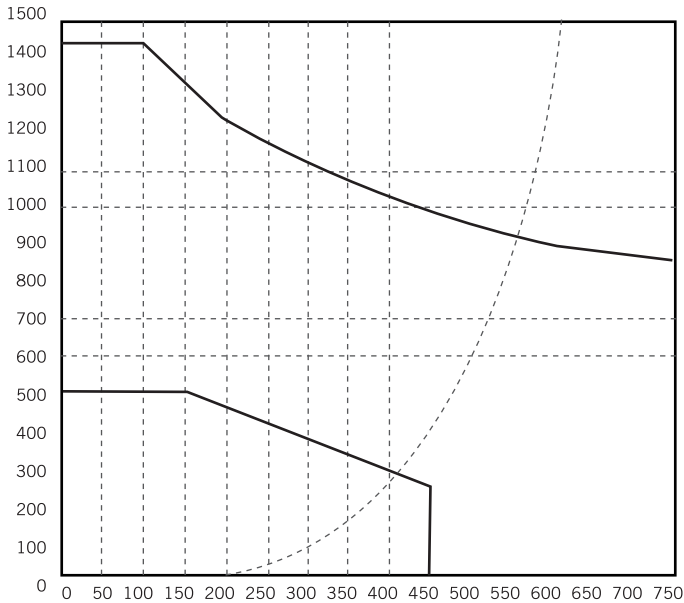

TEMPERATURE (°F)

- SATURATED STEAM
- J1 ANSI/ASME B16.1 CLASS 250 CAST IRON
- J3 ANSI/ASME B16.34 CLASS 600 STAINLESS STEEL

TYPE J CONTROL VALVE

The valve shall be single seated, top guided compact pneumatic globe control valve with a streamlined body. The actuator shall have all SS hardware with a maximum deadband of .3 PSIG. the valve trim shall be all 316SS with replaceable threaded seats for easy maintenance. Standard packing shall be spring loaded Teflon V-Rings. Optional graphite or high temperature packings available. The valve seat leakage shall conform to ANSI/ISA 70-2 Class IV for metal seats and Class VI for Teflon soft seats. The valve shall conform to NEMUR 4 for mounting of accessories

MATERIALS OF CONSTRUCTION

Body	316 SS ASTM A351 CF8M
.....	Cast Iron ASTM A126 CL B
Seat Ring	SS ASTM A276 Cond A
Packing	PTFE V ring
.....	PTFE/Graphite
.....	Graphite
Plug and Stem Ass'y	316 SS ASTM A276 Cond A
Yoke	DI ASTM A536/Epoxy
Diaphragm	Nitrile/Polyester
Piston	316 SS ASTM A743 Grd CF8
Spring	Music Wire ASTM A228
Actuator Housing	Steel SAE 1006-1008/Epoxy

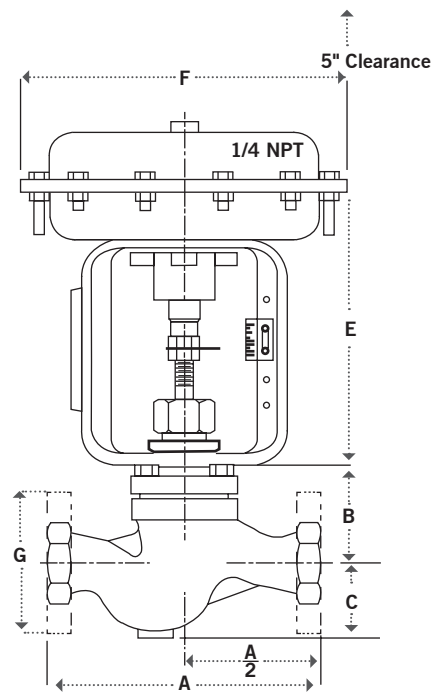

DIMENSIONS INCHES AND WEIGHTS POUNDS

Size	A		B		C		E		F		G (Flange diameter)		Weights*			
	Scrd.	Flg.	36in.2	60in.2	36in.2	62in.3	36in.2	60in.2	150	300/600	Screwed 36in.2	60in.2	Flanged 36in.2	60in.2		
1/2	7 5/8	8	2 11/16	1 7/8	9-7/8	11 7/8	9 1/4	11-1/4	3 1/2	33/4	20 1/2	36 1/2	23 1/2	39 1/2		
3/4	7 5/8	8 1/8	2 11/16	1 7/8	9-7/8	11 7/8	9 1/4	11-1/4	3 7/8	45/8	20 1/2	36 1/2	25-3/4	41 3/4		
1	7 3/4	8 1/4	2 3/4	2 1/8	9-7/8	11 7/8	9 1/4	11-1/4	4 1/4	47/8	22-1/2	38 3/4	29	45 1/4		
1 1/2	9 1/4	9-7/8	33/8	2 11/16	9-7/8	11 7/8	9 1/4	11-1/4	5	61/8	29 1/4	45 1/2	40 1/4	57 1/2		
2	10 1/2	11-1/4	3 9/32	3 5/16	9-7/8	11 7/8	9 1/4	11-1/4	6	6 1/2	38 1/4	54 1/4	50 1/4	68 1/4		

*Weights are approximate

PRESSURE RECOVERY FACTORS

FOR GAS: XT=0.7, FOR FL: SEE CHART

1/2		3/4			1				1 1/2			2		
1/4	5/8	1/4	5/8	7/8	1/4	5/8	7/8	1 1/4	7/8	1 1/4	1 3/4	1 1/4	1 3/4	2 1/4
.851	.79	.864	.82	.775	.869	.839	.805	.768	.843	.82	.782	.841	.811	.772

CONTROL VALVES

SHUTOFF AND CV TABLES

ACTUATOR SHUTOFF TABLE

PORT SIZE	ACTUATOR SIZE	BENCH RANGE	REVERSE SHUTOFF		BENCH RANGE	DIRECT SHUTOFF	
			3-15 PSI	0-20 PSI*		3-15 PSI	0-20 PSI
1/8	36	5 - 15	0 - 750	0 - 750	3 - 13	0 - 750	0 - 750
3/16,1/4	36	5 - 15	0 - 250	0 - 750	3 - 13	0 - 250	0 - 750
5/8	36	5 - 15	----	0 - 50	3 - 10	0 - 300	0 - 750
		8 - 15	0 - 350	50 - 500	3 - 5	300 - 750	300 - 750
		10 - 15	350 - 550	500 - 750	----	----	----
7/8	36	8 - 15	0 - 200	0 - 300	3 - 10	0 - 150	0 - 350
		10 - 15	200 - 300	300 - 450	3 - 5	150 - 400	350 - 650
	60	8 - 15	0 - 500	0 - 700	3 - 11	0 - 300	0 - 600
		10 - 15	500 - 650	700 - 750	3 - 8	300 - 500	600 - 750
1-1/4	36	12 - 15	650 - 750	----	----	----	----
		----	----	----	3 - 10	0 - 150	0 - 300
	60	10 - 15	0 - 150	0 - 225	3 - 5	150 - 225	300 - 375
		8 - 15	0 - 200	0 - 300	3 - 11	0 - 150	0 - 350
		10 - 15	200 - 250	300 - 350	3 - 8	150 - 250	350 - 450
		12 - 15	250 - 300	350 - 400	----	----	----
20 - 60**	----	0 - 750**	----	----	----		
10 - 15	0 - 75	0 - 125	3 - 5	0 - 100	0 - 200		
1-3/4	36	8 - 15	0 - 75	0 - 125	3 - 11	0 - 100	0 - 200
		10 - 15	75 - 125	125 - 175	3 - 8	100 - 125	200 - 250
	60	12 - 15	125 - 175	175 - 225	----	----	----
		20 - 60**	----	0 - 375**	----	----	----
2-1/4	60	11 - 15	0 - 100	0 - 125	3 - 10	0 - 50	0 - 100
		20 - 60**	----	0 - 225**	----	----	----

* Based on 20 psi air supply with EPC or Positioner.

** Based on 60 psi air supply with EPC or Positioner.

NOTES:

- 1) For pressures over 750 psi please consult factory
- 2) For direct configured actuators 60 psi air signal will achieve 750 psi shutoff except for 2.25 port which will achieve 650 psi shutoff
- 3) Do not exceed 60 psi air signal to actuator

ACTUATOR SELECTION

Select Actuator size and bench range that will accommodate require shut off with port size selected. Select reverse for air to open fail close applications, direct for air to close fail open applications

CV TABLE

SIZE	TRAVEL	PORT SIZE	PLUG CON-TOUR	PERCENT OF TRAVEL										
				5	10	20	30	40	50	60	70	80	90	100
1/2	3/4	1/8	EP	0.002	0.003	0.006	0.011	0.021	0.032	0.042	0.052	0.062	0.072	0.08
		3/16	EP	0.004	0.008	0.014	0.021	0.03	0.045	0.063	0.095	0.145	0.25	0.5
		1/4	EP	0.03	0.04	0.07	0.12	0.18	0.25	0.36	0.49	0.7	1.1	1.5
		5/8	MEP	0.05	0.1	0.18	0.31	0.49	0.73	1.1	1.6	2.3	3.4	5.1
3/4	3/4	1/8	EP	0.002	0.003	0.006	0.011	0.021	0.032	0.042	0.052	0.062	0.072	0.08
		3/16	EP	0.004	0.008	0.014	0.021	0.03	0.045	0.063	0.095	0.145	0.25	0.5
		1/4	EP	0.03	0.04	0.07	0.12	0.18	0.25	0.36	0.49	0.7	1.1	1.5
		5/8	MEP	0.05	0.07	0.18	0.31	0.47	0.73	1.1	1.6	2.4	3.8	6
1	3/4	7/8	MEP	0.07	0.19	0.58	1	1.3	1.9	2.5	3.8	5.7	8.7	10.3
		5/8	MEP	0.04	0.07	0.16	0.31	0.54	0.79	1.1	1.8	2.2	4	6.2
		1-1/4	MEP	0.09	0.27	0.63	1	1.4	3.2	5.3	7.5	11.5	15.6	18.2
1-1/2	3/4	7/8	MEP	0.11	0.21	0.54	0.89	1.4	1.9	2.7	3.9	6.4	10.1	13.2
		1-1/4	MEP	0.14	0.37	0.99	1.5	2.4	3.6	5.3	7.5	12.3	16.8	22
		1-3/4	MEP	0.41	0.85	2.4	4.3	6.4	9.9	15.7	22.7	29	34.2	37
2	3/4	1-1/4	MEP	0.14	0.37	0.99	1.5	2.4	3.6	5.3	7.5	12.3	17.3	23
		1-3/4	MEP	0.41	0.85	2.4	4.3	6.5	10	16	23	31	37	43
		1 1/16	2-1/4	MEP	0.75	1.5	3.5	6.5	10.5	15.5	26	39	50	60

SATURATED STEAM CAPACITY TABLE

(Lbs /Hr.)

PRESSURE (PSI)		VALVE SIZE AND PORT																	
		1/2			3/4					1			1-1/2			2			
P1	P2	1/8	3/16	1/4	5/8	1/8	3/16	1/4	5/8	7/8	5/8	7/8	1-1/4	7/8	1-1/4	1-3/4	1-1/4	1-3/4	2-1/4
10	5	2	16	47	159	2	16	47	187	322	194	378	569	412	687	1156	719	1344	2094
	3	3	18	53	181	3	18	53	213	366	220	430	646	469	781	1314	817	1527	2380
15	10	3	17	52	177	3	17	52	208	357	215	419	630	457	762	1281	796	1489	2320
	7	3	21	62	212	3	21	62	250	429	258	503	757	549	915	1540	957	1789	2788
20	5	4	22	67	229	4	22	67	269	463	278	543	817	593	988	1662	1033	1931	3009
	15	3	19	56	192	3	19	56	226	387	233	455	685	497	828	1392	865	1617	2520
	10	4	25	74	253	4	25	74	297	510	307	599	902	654	1090	1833	1139	2130	3319
30	7	4	27	81	275	4	27	81	324	555	334	652	981	712	1186	1995	1240	2319	3613
	22	4	26	79	268	4	26	79	315	541	326	636	957	694	1156	1945	1209	2260	3522
	17	5	32	95	323	5	32	95	380	652	393	766	1153	836	1393	2343	1457	2723	4243
40	10	6	36	108	369	6	36	108	434	744	448	874	1315	954	1590	2674	1662	3108	4842
	25	6	38	113	384	6	38	113	452	775	467	911	1370	994	1656	2786	1732	3237	5044
50	20	7	41	124	423	7	41	124	497	854	514	1003	1508	1094	1823	3067	1906	3564	5553
	3-0	8	47	141	480	8	47	141	564	969	583	1138	1711	1241	2069	3479	2163	4043	6300
	35	7	42	125	424	7	42	125	498	855	515	1005	1511	1096	1827	3073	1910	3571	5564
	30	7	46	138	470	7	46	138	553	950	572	1116	1679	1217	2029	3413	2121	3966	6179
60	25	8	49	148	505	8	49	148	594	1019	614	1198	1801	1307	2178	3662	2277	4256	6632
	6-0	9	55	166	564	9	55	166	663	1139	686	1338	2013	1460	2433	4091	2543	4755	7409
	45	7	45	135	460	7	45	135	541	928	559	1090	1640	1189	1982	3334	2072	3874	6037
	40	8	50	151	513	8	50	151	604	1036	624	1217	1831	1328	2213	3722	2313	4325	6739
75	35	9	54	163	554	9	54	163	652	1119	674	1315	1977	1434	2390	4020	2499	4672	7279
	9-0	10	64	191	648	10	64	191	763	1309	788	1538	2314	1678	2797	4704	2924	5466	8517
	55	9	56	168	571	9	56	168	671	1153	694	1354	2036	1477	2462	4140	2574	4811	7497
	50	10	61	182	620	10	61	182	730	1253	754	1472	2214	1606	2677	4501	2798	5231	8151
100	45	10	65	194	660	10	65	194	777	1334	803	1567	2356	1709	2848	4791	2978	5568	8675
	14-0	12	76	227	772	12	76	227	909	1560	939	1833	2757	1999	3332	5604	3484	6513	10148
	75	11	70	210	715	11	70	210	841	1444	869	1697	2552	1851	3085	5188	3225	6029	9394
125	60	13	83	249	847	13	83	249	996	1710	1029	2009	3021	2191	3652	6142	3818	7138	11122
	22-0	15	96	288	978	15	96	288	1151	1975	1189	2321	3491	2532	4219	7096	4411	8247	12850
150	100	13	78	234	797	13	78	234	938	1609	969	1891	2844	2063	3438	5782	3594	6719	10469
	75	16	101	303	1030	16	101	303	1212	2081	1252	2444	3676	2666	4444	7474	4646	8686	13534
175	30-0	19	116	348	1182	19	116	348	1391	2388	1437	2805	4220	3060	5101	8578	5332	9969	15534
	125	14	86	257	875	14	86	257	1029	1766	1063	2075	3121	2264	3773	6346	3945	7375	11491
	100	18	112	336	1142	18	112	336	1343	2306	1388	2709	4074	2955	4925	8283	5149	9626	14998
200	38-0	22	136	407	1385	22	136	407	1629	2796	1683	3285	4941	3584	5973	10045	6244	11674	18190
	150	15	92	275	936	15	92	275	1101	1890	1138	2221	3340	2422	4037	6790	4221	7891	12296
	125	20	122	367	1249	20	122	367	1469	2522	1518	2963	4457	3232	5387	9060	5632	10529	16406
	100	22	139	418	1421	22	139	418	1672	2870	1728	3372	5072	3678	6131	10311	6409	11983	18671
225	46-0	25	155	466	1585	25	155	466	1865	3202	1927	3761	5657	4103	6838	11501	7149	13366	20826
	150	21	131	392	1333	21	131	392	1569	2693	1621	3164	4759	3451	5752	9674	6014	11243	17518
	125	24	152	455	1549	24	152	455	1822	3127	1883	3674	5526	4008	6680	11235	6984	13056	20344
250	54-0	28	175	525	1784	28	175	525	2098	3602	2168	4232	6365	4616	7694	12939	8043	15038	23431
	175	22	139	417	1418	22	139	417	1669	2865	1724	3365	5062	3671	6119	10291	6397	11960	18635
250	150	26	162	485	1649	26	162	485	1940	3331	2005	3913	5885	4268	7114	11964	7437	13904	21665
	63-0	31	194	583	1981	31	194	583	2330	4001	2408	4700	7069	5127	8545	14371	8933	16701	26023
	200	23	147	441	1498	23	147	441	1762	3025	1821	3554	5345	3877	6461	10866	6755	12628	19676
	175	27	172	515	1751	27	172	515	2060	3536	2129	4154	6249	4532	7554	12704	7897	14764	23004
250	150	30	189	566	1926	30	189	566	2266	3889	2341	4569	6872	4984	8307	13971	8685	16237	25300
	71-0	34	214	641	2179	34	214	641	2564	4401	2649	5170	7776	5640	9400	15808	9827	18372	28626

CONTROL
VALVES

- It is recommended to keep valve outlet velocity below 30,000 ft./min.
- Capacities based on maximum Cv.

SATURATED STEAM CAPACITY TABLE

(Kg./Hr.)

PRESSURE		VALVE SIZE AND PORT																	
(BAR)		1/2				3/4				1			1-1/2			2			
P1	P2	1/8	3/16	1/4	5/8	1/8	3/16	1/4	5/8	7/8	5/8	7/8	1-1/4	7/8	1-1/4	1-3/4	1-1/4	1-3/4	2-1/4
0.7	0.3	1	8	23	77	1	8	23	90	155	93	182	274	199	331	557	346	647	1008
	0.2	1	8	25	83	1	8	25	98	169	101	198	298	216	360	606	376	704	1097
1	0.7	1	7	22	75	1	7	22	88	151	91	178	267	194	323	543	337	631	983
	0.5	1	9	27	92	1	9	27	108	186	112	218	328	238	397	667	415	775	1208
	0.3	2	10	30	103	2	10	30	121	208	125	245	368	267	445	748	465	869	1354
1.5	1	2	10	31	104	2	10	31	123	211	127	247	372	270	450	756	470	879	1370
	0.7	2	12	37	124	2	12	37	146	251	151	295	444	322	536	902	561	1048	1633
	0.5	2	13	39	133	2	13	39	157	269	162	316	475	345	574	966	600	1122	1749
2	1.5	2	11	34	115	2	11	34	136	233	140	273	411	298	497	836	520	972	1514
	1.2	2	14	41	139	2	14	41	163	280	169	329	495	359	599	1007	626	1170	1823
	1	2	15	44	151	2	15	44	178	305	184	358	539	391	651	1095	681	1273	1983
3	2	3	18	53	179	3	18	53	211	362	218	425	639	464	773	1299	808	1510	2353
	1.5	3	20	60	205	3	20	60	241	414	249	487	732	531	885	1489	925	1730	2696
	.3-0	4	23	68	231	4	23	68	272	467	281	549	826	599	998	1679	1044	1951	3040
3.5	3.0	2	14	42	143	2	14	42	169	289	174	340	511	371	618	1040	646	1208	1883
	2.0	3	22	65	221	3	22	65	260	446	268	524	788	571	952	1601	996	1861	2900
	1.0	4	24	73	249	4	24	73	293	503	303	591	889	645	1075	1808	1124	2101	3273
4	.4-0	4	25	76	259	4	25	76	304	523	315	614	923	670	1116	1877	1167	2181	3399
	3.0	3	20	59	202	3	20	59	238	409	246	480	722	524	873	1468	912	1706	2657
	2.0	4	25	75	256	4	25	75	301	517	311	607	913	662	1104	1856	1154	2158	3362
5	1.0	4	27	81	276	4	27	81	325	558	336	656	986	715	1192	2005	1246	2330	3631
	.6-0	4	28	84	286	4	28	84	337	578	348	679	1021	741	1234	2076	1290	2413	3759
	4.0	4	22	66	224	4	22	66	264	453	272	532	800	580	967	1625	1010	1889	2943
7	3.0	5	28	85	290	5	28	85	341	585	352	687	1034	750	1250	2101	1306	2442	3805
	2.0	5	31	94	321	5	31	94	378	649	391	762	1146	831	1386	2331	1449	2708	4220
	.9-0	5	33	100	341	5	33	100	401	688	414	808	1215	881	1469	2471	1536	2871	4474
9	5.0	5	34	102	345	5	34	102	406	698	420	820	1233	894	1490	2506	1558	2913	4538
	3.0	7	42	125	424	7	42	125	499	856	515	1006	1513	1097	1829	3075	1912	3574	5569
	1.6-0	7	44	132	449	7	44	132	529	908	546	1066	1604	1163	1939	3260	2027	3789	5904
10	7.0	6	38	115	392	6	38	115	462	793	477	931	1400	1016	1693	2847	1770	3309	5155
	5.0	8	49	147	500	8	49	147	589	1010	608	1187	1786	1295	2158	3630	2256	4219	6573
	2.1-0	9	55	164	557	9	55	164	656	1126	678	1322	1989	1442	2404	4043	2513	4699	7321
12	8.0	6	41	122	414	6	41	122	487	836	503	982	1478	1072	1786	3004	1867	3491	5439
	5.0	9	55	165	561	9	55	165	660	1132	682	1330	2001	1451	2419	4068	2529	4727	7366
	2.5-0	10	60	179	609	10	60	179	716	1230	740	1445	2173	1576	2627	4417	2746	5134	7999
14	10.0	7	44	133	451	7	44	133	530	910	548	1069	1608	1167	1944	3270	2033	3800	5921
	7.0	10	62	186	634	10	62	186	746	1280	771	1504	2262	1641	2735	4599	2859	5345	8328
	5.0	11	67	201	683	11	67	201	803	1379	830	1620	2437	1768	2946	4955	3080	5758	8972
15	3.2-0	11	70	210	715	11	70	210	841	1444	869	1697	2552	1851	3085	5188	3225	6030	9395
	10.0	10	63	189	644	10	63	189	757	1300	783	1527	2297	1666	2777	4670	2903	5427	8456
	7.0	12	75	225	766	12	75	225	901	1546	931	1817	2733	1982	3303	5555	3453	6456	10059
17	3.8-0	13	80	241	820	13	80	241	965	1656	997	1946	2927	2123	3538	5950	3699	6915	10775
	12.0	9	59	176	597	9	59	176	703	1207	726	1417	2132	1546	2577	4334	2694	5037	7849
	10.0	11	71	213	724	11	71	213	852	1462	880	1718	2584	1874	3123	5253	3265	6104	9511
17	4.2-0	14	85	256	870	14	85	256	1024	1758	1058	2065	3106	2252	3754	6313	3925	7337	11432
	15.0	8	53	158	536	8	53	158	630	1082	651	1271	1911	1386	2310	3885	2415	4515	7035
	12.0	12	76	229	778	12	76	229	915	1572	946	1846	2777	2014	3357	5645	3509	6561	10223
17	10.0	14	85	255	868	14	85	255	1022	1754	1056	2060	3099	2248	3746	6300	3916	7322	11408
	4.8-0	15	96	287	975	15	96	287	1147	1969	1185	2314	3480	2524	4206	7075	4398	8222	12811

- It is recommended to keep valve outlet velocity below 30,000 ft./min.
- Capacities based on maximum Cv.

AIR CAPACITY TABLE

(SCFH)

PRESSURE (PSI)		VALVE SIZE AND PORT																	
		1/2			3/4				1			1-1/2			2				
P1	P2	1/8	3/16	1/4	5/8	1/8	3/16	1/4	5/8	7/8	5/8	7/8	1-1/4	7/8	1-1/4	1-3/4	1-1/4	1-3/4	2-1/4
10	5	48	300	901	3064	48	300	901	3605	6189	3725	7270	10936	7931	13219	22232	13820	25837	40258
	3	55	341	1023	3477	55	341	1023	4091	7023	4227	8250	12409	9000	15000	25227	15682	29318	45682
15	10	54	335	1005	3418	54	335	1005	4021	6904	4156	8110	12199	8847	14745	24799	15416	28821	44907
	7	64	403	1208	4106	64	403	1208	4831	8293	4992	9743	14655	10629	17714	29792	18519	34623	53948
20	5	69	434	1303	4429	69	434	1303	5211	8945	5385	10508	15806	11464	19106	32133	19975	37344	58188
	15	59	367	1100	3739	59	367	1100	4399	7552	4546	8872	13345	9678	16131	27129	16864	31528	49126
30	10	77	482	1445	4914	77	482	1445	5781	9924	5973	11658	17535	12718	21196	35648	22160	41429	64552
	7	84	524	1572	5346	84	524	1572	6290	10797	6499	12684	19078	13837	23062	38786	24110	45075	70234
40	22	83	517	1552	5276	83	517	1552	6208	10656	6414	12519	18830	13657	22761	38280	23796	44488	69318
	17	100	623	1868	6350	100	623	1868	7470	12824	7719	15065	22660	16435	27391	46067	28636	53537	83419
50	10	113	708	2124	7222	113	708	2124	8497	14586	8780	17135	25774	18693	31155	52398	32572	60895	94882
	25	119	746	2239	7612	119	746	2239	8955	15373	9253	18059	27163	19701	32835	55222	34327	64177	99996
60	20	131	820	2461	8367	131	820	2461	9844	16898	10172	19851	29859	21656	36094	60703	37734	70547	109922
	3-0	148	924	2773	9429	148	924	2773	11093	19043	11463	22371	33649	24405	40674	68407	42523	79500	123871
75	35	133	830	2489	8463	133	830	2489	9956	17091	10288	20078	30200	21903	36505	61395	38164	71351	111174
	30	147	920	2760	9384	147	920	2760	11040	18951	11408	22263	33487	24287	40478	68077	42318	79117	123275
100	25	158	986	2958	10057	158	986	2958	11832	20312	12227	23862	35891	26031	43385	72966	45357	84798	132127
	6-0	175	1094	3281	11156	175	1094	3281	13124	22530	13562	26467	39810	28873	48122	80933	50310	94057	146555
125	45	145	906	2717	9238	145	906	2717	10868	18657	11231	21918	32967	23910	39850	67021	41662	77889	121362
	40	162	1010	3031	10306	162	1010	3031	12125	20814	12529	24452	36778	26674	44457	74769	46478	86894	135393
150	35	174	1090	3270	11119	174	1090	3270	13081	22455	13517	26380	39679	28778	47963	80665	50143	93746	146070
	9-0	202	1263	3789	12882	202	1263	3789	15155	26017	15661	30563	45971	33342	55570	93459	58096	108614	169236
200	55	181	1133	3399	11558	181	1133	3399	13598	23343	14051	27422	41247	29915	49859	83853	52125	97451	151842
	50	197	1231	3692	12554	197	1231	3692	14769	25354	15262	29785	44800	32493	54154	91078	56616	105847	164925
250	45	209	1309	3926	13349	209	1309	3926	15704	26959	16228	31670	47636	34549	57582	96843	60199	112547	175364
	14-0	243	1516	4549	15466	243	1516	4549	18195	31236	18802	36694	55193	40030	66717	112206	69749	130401	203183
300	75	230	1436	4309	14650	230	1436	4309	17235	29587	17810	34758	52281	37918	63196	106285	66069	123520	192462
	60	271	1696	5087	17295	271	1696	5087	20347	34928	21025	41032	61718	44763	74604	125471	77995	145817	227204
400	22-0	310	1939	5817	19777	310	1939	5817	23267	39941	24042	46921	70576	51187	85311	143478	89189	166745	259811
	100	259	1617	4850	16490	259	1617	4850	19400	33303	20046	39123	58846	42679	71132	119631	74365	139031	216630
500	125	333	2082	6245	21232	333	2082	6245	24979	42881	25812	50375	75770	54954	91591	154039	95754	179018	278935
	30-0	378	2361	7084	24087	378	2361	7084	28338	48647	29282	57148	85958	62343	103906	174750	108629	203088	316440
600	125	285	1779	5338	18148	285	1779	5338	21350	36651	22062	43057	64763	46971	78285	131660	81843	153011	238412
	100	372	2328	6983	23742	372	2328	6983	27932	47950	28863	56330	84727	61450	102417	172247	107073	200179	311907
800	38-0	445	2784	8352	28398	445	2784	8352	33409	57352	34523	67375	101341	73500	122500	206023	128068	239432	373068
	150	309	1928	5785	19669	309	1928	5785	23140	39723	23911	46665	70191	50907	84846	142695	88702	165835	258394
1000	125	408	2551	7654	26024	408	2551	7654	30617	52559	31637	61744	92871	67357	112262	188804	117365	219421	341889
	100	466	2910	8729	29679	466	2910	8729	34917	59940	36080	70415	105914	76816	128027	215319	133847	250235	389902
1200	46-0	513	3207	9620	32708	513	3207	9620	38480	66058	39763	77602	116723	84657	141094	237295	147508	275775	429696
	150	441	2758	8274	28130	441	2758	8274	33094	56812	34197	66740	100385	72807	121345	204080	126861	237174	369551
1500	125	508	3175	9526	32390	508	3175	9526	38105	65414	39376	76846	115587	83832	139720	234984	146071	273089	425511
	54-0	581	3629	10888	37019	581	3629	10888	43551	74763	45003	87829	132106	95813	159689	268567	166947	312119	486325
2000	175	472	2950	8851	30094	472	2950	8851	35404	60778	36585	71399	107394	77890	129816	218328	135717	253732	395350
	150	548	3422	10266	34905	548	3422	10266	41065	70495	42434	82815	124564	90343	150572	253235	157416	294300	458560
2500	63-0	648	4051	12152	41317	648	4051	12152	48608	83444	50229	98027	147445	106938	178230	299751	186332	348359	542792
	200	501	3131	9394	31941	501	3131	9394	37577	64507	38830	75781	113984	82670	137783	231726	144046	269303	419612
3000	175	584	3653	10959	37262	584	3653	10959	43837	75254	45298	88405	132973	96442	160736	270329	168043	314167	489515
	150	641	4008	12024	40881	641	4008	12024	48096	82564	49699	96993	145890	105810	176350	296589	184366	344685	537067
4000	71-0	716	4473	13420	45628	716	4473	13420	53680	92150	55469	108254	162828	118095	196825	331024	205771	384703	599421

CONTROL VALVES

- It is recommended to keep valve outlet velocity below 30,000 ft./min.
- Capacities based on maximum Cv.

AIR CAPACITY TABLE

(M³/Hr)

PRESSURE (BAR)		VALVE SIZE AND PORT																	
		1/2				3/4				1			1-1/2			2			
P1	P2	1/8	3/16	1/4	5/8	1/8	3/16	1/4	5/8	7/8	5/8	7/8	1-1/4	7/8	1-1/4	1-3/4	1-1/4	1-3/4	2-1/4
0.7	0.3	1.4	9.0	27	92	1.4	9.0	27	109	186	112	219	329	239	398	669	416	778	1212
	0.2	1.6	10	29	100	1.6	10	29	118	202	122	237	357	259	432	726	451	844	1315
1	0.7	1.4	8.9	27	90	1.4	8.9	27	106	183	110	214	323	234	390	656	408	762	1187
	0.5	1.7	11	33	111	1.7	11	33	131	224	135	263	396	287	479	805	500	936	1458
	0.3	2.0	12	37	125	2.0	12	37	147	252	151	295	444	322	537	904	562	1050	1636
1.5	1	2.0	12	37	127	2.0	12	37	150	257	155	302	454	329	549	923	573	1072	1671
	0.7	2.4	15	44	151	2.4	15	44	178	305	184	359	539	391	652	1097	682	1274	1986
	0.5	2.5	16	48	162	2.5	16	48	190	327	197	384	577	419	698	1174	730	1364	2125
2	1.5	2.2	14	42	142	2.2	14	42	167	286	172	336	505	366	611	1027	638	1194	1860
	1.2	2.7	17	50	170	2.7	17	50	200	344	207	404	607	441	734	1235	768	1435	2236
	1	2.9	18	54	184	2.9	18	54	216	371	223	436	655	475	792	1333	828	1549	2413
3	2	3.5	22	65	221	3.5	22	65	261	447	269	525	790	573	955	1607	999	1867	2909
	1.5	4.0	25	75	254	4.0	25	75	299	512	308	602	905	657	1095	1841	1144	2139	3333
	1.3	4.5	28	84	284	4.5	28	84	334	574	345	674	1014	735	1225	2060	1281	2395	3731
3.5	3.0	2.8	17	52	178	2.8	17	52	209	359	216	422	635	461	768	1291	803	1501	2338
	2.0	4.3	27	81	275	4.3	27	81	324	556	335	653	982	712	1187	1997	1241	2321	3616
	1.0	4.9	31	92	313	4.9	31	92	368	631	380	742	1116	809	1349	2268	1410	2636	4108
4	4.0	5.0	31	94	320	5.0	31	94	376	646	389	758	1141	827	1379	2319	1442	2695	4200
	3.0	4.0	25	75	254	4.0	25	75	299	513	309	602	906	657	1095	1842	1145	2141	3336
	2.0	5.1	32	95	323	5.1	32	95	380	652	393	766	1152	836	1393	2342	1456	2722	4242
5	1.0	5.5	34	103	351	5.5	34	103	413	709	427	833	1253	909	1515	2547	1583	2960	4613
	0.6	5.6	35	104	355	5.6	35	104	418	717	431	842	1267	919	1531	2575	1601	2992	4662
	4.0	4.4	28	83	283	4.4	28	83	333	571	344	671	1009	732	1220	2051	1275	2384	3714
7	3.0	5.8	36	108	367	5.8	36	108	432	741	446	870	1309	949	1582	2661	1654	3093	4819
	2.0	6.4	40	120	409	6.4	40	120	481	826	497	970	1459	1058	1763	2965	1843	3446	5370
	0.9	6.7	42	125	426	6.7	42	125	501	860	518	1010	1520	1102	1837	3089	1920	3590	5594
9	5.0	6.9	43	130	442	6.9	43	130	521	894	538	1050	1579	1145	1909	3210	1995	3731	5813
	3.0	8.5	53	160	545	8.5	53	160	641	1100	662	1292	1944	1410	2350	3952	2457	4593	7157
	1.6	8.9	56	167	567	8.9	56	167	667	1145	689	1345	2024	1468	2446	4114	2557	4781	7450
10	7.0	8.0	50	149	507	8.0	50	149	597	1025	617	1204	1811	1313	2189	3681	2288	4278	6666
	5.0	10	63	190	645	10	63	190	759	1303	784	1531	2302	1670	2783	4680	2909	5439	8475
	2.1	11	70	209	709	11	70	209	834	1433	862	1683	2531	1836	3060	5146	3199	5981	9318
12	8.0	8.4	53	158	537	8.4	53	158	632	1085	653	1274	1916	1390	2316	3896	2422	4528	7055
	5.0	12	72	216	733	12	72	216	863	1481	891	1740	2617	1898	3163	5319	3307	6182	9632
	2.5	12	76	229	780	12	76	229	917	1575	948	1850	2783	2018	3364	5657	3517	6575	10244
14	10.0	9.3	58	174	592	9.3	58	174	696	1195	720	1404	2112	1532	2553	4294	2669	4990	7776
	7.0	13	81	244	829	13	81	244	976	1675	1008	1967	2959	2146	3577	6016	3740	6992	10894
	5.0	14	88	264	897	14	88	264	1055	1812	1091	2129	3202	2322	3870	6509	4046	7564	11786
15	3.2	14	90	271	921	14	90	271	1084	1860	1120	2185	3287	2384	3973	6682	4154	7766	12100
	10.0	13	83	250	849	13	83	250	999	1715	1032	2014	3030	2197	3662	6159	3829	7158	11153
	7.0	16	99	296	1006	16	99	296	1183	2031	1223	2386	3589	2603	4338	7296	4536	8480	13212
17	3.8	17	104	313	1063	17	104	313	1250	2147	1292	2522	3793	2751	4585	7711	4793	8961	13963
	12.0	12	78	233	791	12	78	233	930	1597	961	1876	2822	2047	3411	5737	3566	6667	10388
	10.0	15	94	281	957	15	94	281	1126	1932	1163	2270	3414	2476	4127	6942	4315	8067	12570
17	4.2	18	111	333	1133	18	111	333	1333	2289	1378	2689	4044	2933	4888	8222	5111	9555	14888
	15.0	11	70	209	711	11	70	209	837	1436	864	1687	2537	1840	3067	5158	3207	5995	9341
	12.0	16	101	304	1034	16	101	304	1216	2088	1257	2452	3689	2675	4459	7499	4662	8715	13579
17	10.0	18	113	339	1152	18	113	339	1355	2326	1400	2732	4110	2981	4968	8355	5193	9709	15129
	4.8	20	125	375	1275	20	125	375	1500	2575	1550	3025	4550	3300	5500	9250	5750	10750	16751

CONTROL VALVES

- It is recommended to keep valve outlet velocity below 30,000 ft./min.
- Capacities based on maximum Cv.

WATER CAPACITY TABLE

(G.P.M.)

PRESSURE (PSI)		VALVE SIZE AND PORT																	
		1/2			3/4				1			1-1/2			2				
P1	P2	1/8	3/16	1/4	5/8	1/8	3/16	1/4	5/8	7/8	5/8	7/8	1-1/4	7/8	1-1/4	1-3/4	1-1/4	1-3/4	2-1/4
10	5	0.18	1.1	3.4	11.4	0.18	1.1	3.4	13.4	23.0	13.9	27.1	40.7	29.5	49.2	82.7	51.4	96.2	150
	4	0.20	1.2	3.7	12.5	0.20	1.2	3.7	14.7	25.2	15.2	29.6	44.6	32.3	53.9	90.6	56.3	105	164
15	10	0.18	1.1	3.4	11.4	0.18	1.1	3.4	13.4	23.0	13.9	27.1	40.7	29.5	49.2	82.7	51.4	96.2	150
	7	0.23	1.4	4.2	14.4	0.23	1.4	4.2	17.0	29.1	17.5	34.2	51.5	37.3	62.2	105	65	122	190
	6	0.24	1.5	4.5	15.3	0.24	1.5	4.5	18.0	30.9	18.6	36.3	54.6	39.6	66.0	111	69	129	201
20	15	0.18	1.1	3.4	11.4	0.18	1.1	3.4	13.4	23.0	13.9	27.1	40.7	29.5	49.2	82.7	51.4	96.2	150
	10	0.25	1.6	4.7	16.1	0.25	1.6	4.7	19.0	32.6	19.6	38.3	57.6	41.7	69.6	117	72.7	136	212
	8	0.28	1.7	5.2	17.7	0.28	1.7	5.2	20.8	35.7	21.5	41.9	63.0	45.7	76.2	128	79.7	149	232
30	25	0.18	1.1	3.4	11.4	0.18	1.1	3.4	13.4	23.0	13.9	27.1	40.7	29.5	49.2	83	51.4	96	150
	20	0.25	1.6	4.7	16.1	0.25	1.6	4.7	19.0	32.6	19.6	38.3	57.6	41.7	69.6	117	72.7	136	212
	12	0.34	2.1	6.4	21.6	0.34	2.1	6.4	25.5	43.7	26.3	51.3	77.2	56.0	93.3	157	98	182	284
40	25	0.31	1.9	5.8	19.8	0.31	1.9	5.8	23.2	39.9	24.0	46.9	70.5	51.1	85.2	143	89.1	167	259
	20	0.36	2.2	6.7	22.8	0.36	2.2	6.7	26.8	46.1	27.7	54.1	81.4	59.0	98.4	165	103	192	300
	15	0.40	2.5	7.5	25.5	0.40	2.5	7.5	30.0	51.5	31.0	60.5	91.0	66.0	110	185	115	215	335
50	35	0.31	1.9	5.8	19.8	0.31	1.9	5.8	23.2	39.9	24.0	46.9	70.5	51.1	85.2	143	89.1	167	259
	30	0.36	2.2	6.7	22.8	0.36	2.2	6.7	26.8	46.1	27.7	54.1	81.4	59.0	98.4	165	103	192	300
	25	0.40	2.5	7.5	25.5	0.40	2.5	7.5	30.0	51.5	31.0	60.5	91.0	66.0	110	185	115	215	335
60	15	0.47	3.0	8.9	30.2	0.47	3.0	8.9	35.5	60.9	36.7	71.6	107.7	78.1	130	219	136	254	396
	45	0.31	1.9	5.8	19.8	0.31	1.9	5.8	23.2	39.9	24.0	46.9	70.5	51.1	85.2	143	89.1	167	259
	40	0.36	2.2	6.7	22.8	0.36	2.2	6.7	26.8	46.1	27.7	54.1	81.4	59.0	98.4	165	103	192	300
75	35	0.40	2.5	7.5	25.5	0.40	2.5	7.5	30.0	51.5	31.0	60.5	91.0	66.0	110	185	115	215	335
	25	0.47	3.0	8.9	30.2	0.47	3.0	8.9	35.5	60.9	36.7	71.6	107.7	78.1	130	219	136	254	396
	55	0.36	2.2	6.7	22.8	0.36	2.2	6.7	26.8	46.1	27.7	54.1	81.4	59.0	98.4	165	103	192	300
100	50	0.40	2.5	7.5	25.5	0.40	2.5	7.5	30.0	51.5	31.0	60.5	91.0	66.0	110	185	115	215	335
	45	0.44	2.7	8.2	27.9	0.44	2.7	8.2	32.9	56.4	34.0	66.3	99.7	72.3	120	203	126	236	367
	31	0.53	3.3	9.9	33.8	0.53	3.3	9.9	39.8	68.3	41.1	80.3	121	88	146	245	153	285	444
125	75	0.40	2.5	7.5	25.5	0.40	2.5	7.5	30.0	51.5	31.0	60.5	91.0	66.0	110	185	115	215	335
	60	0.51	3.2	9.5	32.3	0.51	3.2	9.5	37.9	65.1	39.2	76.5	115	83.5	139	234	145	272	424
	50	0.57	3.5	10.6	36.1	0.57	3.5	10.6	42.4	72.8	43.8	86	129	93	156	262	163	304	474
150	100	0.40	2.5	7.5	25.5	0.40	2.5	7.5	30.0	51.5	31.0	60.5	91.0	66.0	110	185	115	215	335
	75	0.57	3.5	10.6	36.1	0.57	3.5	10.6	42.4	72.8	43.8	85.6	129	93.3	156	262	163	304	474
	55	0.67	4.2	12.5	42.7	0.67	4.2	12.5	50.2	86.2	51.9	101	152	110	184	310	192	360	561
175	125	0.40	2.5	7.5	25.5	0.40	2.5	7.5	30.0	51.5	31.0	60.5	91.0	66.0	110	185	115	215	335
	100	0.57	3.5	10.6	36.1	0.57	3.5	10.6	42.4	72.8	43.8	85.6	129	93.3	156	262	163	304	474
	75	0.69	4.3	13.0	44.2	0.69	4.3	13.0	52.0	89.2	53.7	105	158	114	191	320	199	372	580
200	150	0.80	5.0	15.0	51.0	0.80	5.0	15.0	60.0	103	62.0	121	182	132	220	370	230	430	670
	125	0.89	5.6	16.8	57.0	0.89	5.6	16.8	67.1	115	69.3	135	203	148	246	414	257	481	749
	100	0.89	5.6	16.8	57.0	0.89	5.6	16.8	67.1	115	69.3	135	203	148	246	414	257	481	749
225	200	0.57	3.5	10.6	36.1	0.57	3.5	10.6	42.4	72.8	43.8	85.6	129	93.3	156	262	163	304	474
	175	0.69	4.3	13.0	44.2	0.69	4.3	13.0	52.0	89.2	53.7	105	158	114	191	320	199	372	580
	150	0.86	5.4	16.1	54.7	0.86	5.4	16.1	64.3	110	66.5	130	195	142	236	397	247	461	718
250	175	0.57	3.5	10.6	36.1	0.57	3.5	10.6	42.4	72.8	43.8	85.6	129	93.3	156	262	163	304	474
	150	0.69	4.3	13.0	44.2	0.69	4.3	13.0	52.0	89.2	53.7	105	158	114	191	320	199	372	580
	125	0.89	5.6	16.8	57.0	0.89	5.6	16.8	67.1	115	69.3	135	203	148	246	414	257	481	749
300	250	0.57	3.5	10.6	36.1	0.57	3.5	10.6	42.4	72.8	43.8	85.6	129	93.3	156	262	163	304	474
	200	0.80	5.0	15.0	51.0	0.80	5.0	15.0	60.0	103	62.0	121	182	132	220	370	230	430	670
	125	1.1	6.6	19.8	67.5	1.1	6.6	19.8	79.4	136	82.0	160	241	175	291	489	304	569	886
400	350	0.57	3.5	10.6	36.1	0.57	3.5	10.6	42.4	72.8	43.8	85.6	129	93.3	156	262	163	304	474
	300	0.80	5.0	15.0	51.0	0.80	5.0	15.0	60.0	103	62.0	121	182	132	220	370	230	430	670
	175	1.2	7.5	22.5	76.5	1.2	7.5	22.5	90.0	155	93.0	182	273	198	330	555	345	645	1005

CONTROL
VALVES

- It is recommended to keep valve outlet velocity below 30,000 ft./min.
- Capacities based on maximum Cv.

WATER CAPACITY TABLE

(M³/Hr)

PRESSURE (BAR)		VALVE SIZE AND PORT																	
		1/2				3/4					1			1-1/2			2		
P1	P2	1/8	3/16	1/4	5/8	1/8	3/16	1/4	5/8	7/8	5/8	7/8	1-1/4	7/8	1-1/4	1-3/4	1-1/4	1-3/4	2-1/4
0.7	0.5 0.3	0.03	0.2	0.6	2.0	0.03	0.2	0.6	2.3	4.0	2.4	4.7	7.0	5.1	8.5	14.3	8.9	16.6	25.9
		0.04	0.3	0.8	2.8	0.04	0.3	0.8	3.3	5.6	3.4	6.6	10.0	7.2	12.0	20.2	12.6	23.5	36.6
1	0.7 0.5 0.4	0.04	0.2	0.7	2.4	0.04	0.2	0.7	2.8	4.9	2.9	5.7	8.6	6.3	10.4	17.5	10.9	20.4	31.7
		0.05	0.3	0.9	3.1	0.05	0.3	0.9	3.7	6.3	3.8	7.4	11.1	8.1	13.5	22.6	14.1	26.3	41.0
		0.05	0.3	1.0	3.4	0.05	0.3	1.0	4.0	6.9	4.2	8.1	12.2	8.8	14.7	24.8	15.4	28.8	44.9
1.5	1 0.7 0.6	0.05	0.3	0.9	3.1	0.05	0.3	0.9	3.7	6.3	3.8	7.4	11.1	8.1	13.5	22.6	14.1	26.3	41.0
		0.06	0.4	1.2	3.9	0.06	0.4	1.2	4.6	8.0	4.8	9.4	14.1	10.2	17.0	28.6	17.8	33.3	51.8
		0.07	0.4	1.2	4.2	0.07	0.4	1.2	4.9	8.5	5.1	9.9	14.9	10.8	18.0	30.4	18.9	35.3	55.0
2	1.5 1 0.8	0.05	0.3	0.9	3.1	0.05	0.3	0.9	3.7	6.3	3.8	7.4	11.1	8.1	13.5	22.6	14.1	26.3	41.0
		0.07	0.4	1.3	4.4	0.07	0.4	1.3	5.2	8.9	5.4	10.5	15.7	11.4	19.0	32.0	19.9	37.2	57.9
		0.08	0.5	1.4	4.8	0.08	0.5	1.4	5.7	9.8	5.9	11.5	17.2	12.5	20.8	35.1	21.8	40.7	63.5
3	2 1.5 1.0	0.07	0.4	1.3	4.4	0.07	0.4	1.3	5.2	8.9	5.4	10.5	15.7	11.4	19.0	32.0	19.9	37.2	57.9
		0.08	0.5	1.6	5.4	0.08	0.5	1.6	6.4	10.9	6.6	12.8	19.3	14.0	23.3	39.2	24.4	45.5	71.0
		0.10	0.6	1.8	6.2	0.10	0.6	1.8	7.3	12.6	7.6	14.8	22.3	16.1	26.9	45.2	28.1	52.6	81.9
3.5	3 2 1.5 1	0.05	0.3	0.9	3.1	0.05	0.3	0.9	3.7	6.3	3.8	7.4	11.1	8.1	13.5	22.6	14.1	26.3	41.0
		0.08	0.5	1.6	5.4	0.08	0.5	1.6	6.4	10.9	6.6	12.8	19.3	14.0	23.3	39.2	24.4	45.5	71.0
		0.10	0.6	1.8	6.2	0.10	0.6	1.8	7.3	12.6	7.6	14.8	22.3	16.1	26.9	45.2	28.1	52.6	81.9
		0.11	0.7	2.1	7.0	0.11	0.7	2.1	8.2	14.1	8.5	16.5	24.9	18.0	30.1	50.6	31.4	58.8	91.6
4	3.5 3 2 1.7	0.05	0.3	0.9	3.1	0.05	0.3	0.9	3.7	6.3	3.8	7.4	11.1	8.1	13.5	22.6	14.1	26.3	41.0
		0.07	0.4	1.3	4.4	0.07	0.4	1.3	5.2	8.9	5.4	10.5	15.7	11.4	19.0	32.0	19.9	37.2	57.9
		0.10	0.6	1.8	6.2	0.10	0.6	1.8	7.3	12.6	7.6	14.8	22.3	16.1	26.9	45.2	28.1	52.6	81.9
		0.10	0.7	2.0	6.7	0.10	0.7	2.0	7.9	13.5	8.1	15.9	23.9	17.3	28.9	48.5	30.2	56.4	87.9
5	4 3 2.5 2.2	0.07	0.4	1.3	4.4	0.07	0.4	1.3	5.2	8.9	5.4	10.5	15.7	11.4	19.0	32.0	19.9	37.2	57.9
		0.10	0.6	1.8	6.2	0.10	0.6	1.8	7.3	12.6	7.6	14.8	22.3	16.1	26.9	45.2	28.1	52.6	81.9
		0.11	0.7	2.1	7.0	0.11	0.7	2.1	8.2	14.1	8.5	16.5	24.9	18.0	30.1	50.6	31.4	58.8	91.6
		0.12	0.7	2.2	7.4	0.12	0.7	2.2	8.7	14.9	9.0	17.5	26.3	19.1	31.8	53.5	33.3	62.2	97.0
6	5 4 3.5	0.07	0.4	1.3	4.4	0.07	0.4	1.3	5.2	8.9	5.4	10.5	15.7	11.4	19.0	32.0	19.9	37.2	57.9
		0.10	0.6	1.8	6.2	0.10	0.6	1.8	7.3	12.6	7.6	14.8	22.3	16.1	26.9	45.2	28.1	52.6	81.9
		0.11	0.7	2.1	7.0	0.11	0.7	2.1	8.2	14.1	8.5	16.5	24.9	18.0	30.1	50.6	31.4	58.8	91.6
8	10	0.10	0.6	1.8	6.2	0.10	0.6	1.8	7.3	12.6	7.6	14.8	22.3	16.1	26.9	45.2	28.1	52.6	81.9
		0.12	0.7	2.2	7.6	0.12	0.7	2.2	9.0	15.4	9.3	18.1	27.3	19.8	33.0	55.4	34.5	64.4	100
		0.14	0.9	2.6	8.8	0.14	0.9	2.6	10.4	17.8	10.7	20.9	31.5	22.8	38.0	64.0	39.8	74.4	116
10	CO CD 10	0.10	0.6	1.8	6.2	0.10	0.6	1.8	7.3	12.6	7.6	14.8	22.3	16.1	26.9	45.2	28.1	52.6	81.9
		0.14	0.9	2.6	8.8	0.14	0.9	2.6	10.4	17.8	10.7	20.9	31.5	22.8	38.0	64.0	39.8	74.4	116
		0.15	1.0	2.9	9.9	0.15	1.0	2.9	11.6	19.9	12.0	23.4	35.2	25.5	42.5	71.5	44.5	83.1	130
12	10 8 6 5	0.10	0.6	1.8	6.2	0.10	0.6	1.8	7.3	12.6	7.6	14.8	22.3	16.1	26.9	45.2	28.1	52.6	81.9
		0.14	0.9	2.6	8.8	0.14	0.9	2.6	10.4	17.8	10.7	20.9	31.5	22.8	38.0	64.0	39.8	74.4	116
		0.17	1.1	3.2	10.8	0.17	1.1	3.2	12.7	21.8	13.1	25.6	38.6	28.0	46.6	78.4	48.7	91.1	142
		0.18	1.1	3.4	11.7	0.18	1.1	3.4	13.7	23.6	14.2	27.7	41.6	30.2	50.3	84.7	52.6	98.4	153
14	10 8 6	0.14	0.9	2.6	8.8	0.14	0.9	2.6	10.4	17.8	10.7	20.9	31.5	22.8	38.0	64.0	39.8	74.4	116
		0.17	1.1	3.2	10.8	0.17	1.1	3.2	12.7	21.8	13.1	25.6	38.6	28.0	46.6	78.4	48.7	91.1	142
		0.20	1.2	3.7	12.5	0.20	1.2	3.7	14.7	25.2	15.2	29.6	44.5	32.3	53.8	90.5	56.3	105	164
15	12 10 7	0.12	0.7	2.2	7.6	0.12	0.7	2.2	9.0	15.4	9.3	18.1	27.3	19.8	33.0	55.4	34.5	64.4	100
		0.15	1.0	2.9	9.9	0.15	1.0	2.9	11.6	19.9	12.0	23.4	35.2	25.5	42.5	71.5	44.5	83.1	130
		0.20	1.2	3.7	12.5	0.20	1.2	3.7	14.7	25.2	15.2	29.6	44.5	32.3	53.8	90.5	56.3	105	164
17	14 12 10 9	0.12	0.7	2.2	7.6	0.12	0.7	2.2	9.0	15.4	9.3	18.1	27.3	19.8	33.0	55.4	34.5	64.4	100
		0.15	1.0	2.9	9.9	0.15	1.0	2.9	11.6	19.9	12.0	23.4	35.2	25.5	42.5	71.5	44.5	83.1	130
		0.18	1.1	3.4	11.7	0.18	1.1	3.4	13.7	23.6	14.2	27.7	41.6	30.2	50.3	84.7	52.6	98.4	153
		0.20	1.2	3.7	12.5	0.20	1.2	3.7	14.7	25.2	15.2	29.6	44.5	32.3	53.8	90.5	56.3	105	164
20	17 15 9	0.12	0.7	2.2	7.6	0.12	0.7	2.2	9.0	15.4	9.3	18.1	27.3	19.8	33.0	55.4	34.5	64.4	100
		0.15	1.0	2.9	9.9	0.15	1.0	2.9	11.6	19.9	12.0	23.4	35.2	25.5	42.5	71.5	44.5	83.1	130
		0.23	1.4	4.3	14.6	0.23	1.4	4.3	17.2	29.5	17.8	34.7	52.2	37.9	63.1	106	66.0	123	192
27	20 15 12	0.18	1.1	3.4	11.7	0.18	1.1	3.4	13.7	23.6	14.2	27.7	41.6	30.2	50.3	84.7	52.6	98.4	153
		0.24	1.5	4.5	15.3	0.24	1.5	4.5	18.0	30.9	18.6	36.2	54.5	39.5	65.9	111	68.9	129	201
		0.27	1.7	5.0	17.1	0.27	1.7	5.0	20.1	34.5	20.8	40.5	61.0	44.2	73.7	124	77.0	144	224

• It is recommended to keep valve outlet velocity below 30,000 ft./min. • Capacities based on maximum Cv

CONTROL VALVES

NOTES

A series of horizontal dotted lines for taking notes, spanning the width of the page.

CONTROL VALVE

Options and Accessories

PACKING CONFIGURATIONS

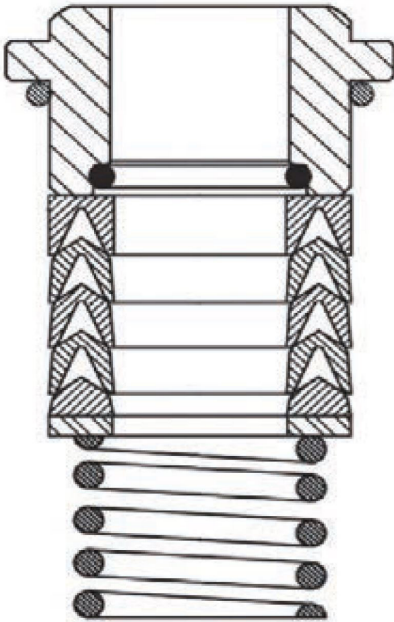

LIVE-LOADED PTFE - V-RING (STANDARD)

Live-loaded PTFE V-ring packing provides the most maintenance free stem seal. The V-ring packing is both pressure energized and live-loaded by a 304 stainless steel spring to automatically compensate for packing wear. Maximum service temperature is 460°F (238°C). V-rings can be inverted for vacuum service.

Available on Boss.

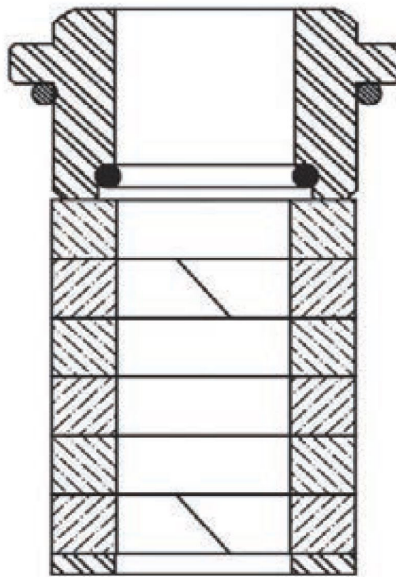

PTFE/GRAPHITE (OPTIONAL)

Split rings allow packing replacement without removal of actuator. Graphite impregnated PTFE provides 500°F (260°C) service temperature, better memory and sealing than pure PTFE rings, lowered stem hysteresis, and is ideal for fluids that contain suspended particles.

Available on Boss.

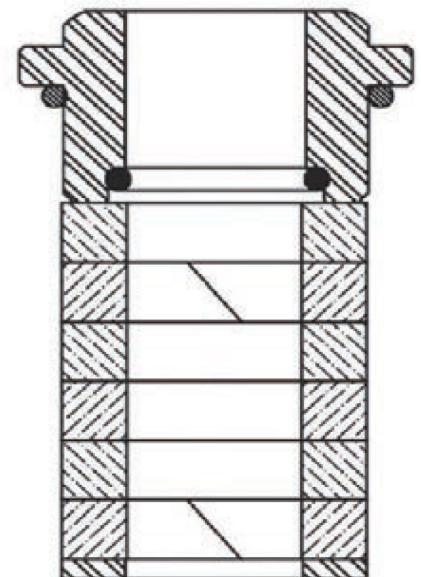

HIGH TEMPERATURE LAMINATED GRAPHITE (OPTIONAL)

Split rings allow packing replacement without removal of actuator. Precision die-cut laminated graphite rings provide a reliable, tight stem seal to operating temperatures of 800+°F (426°C).

Available on Boss.

ACTUATORS



K1, K4

- Pneumatic Actuated
- 36 and 60 sq. in.
- High Thrust Multiple Spring
- Epoxy Coated
- stainless Steel Internals
- Fixed 3-15 pound Springs
- Cast Iron Yoke



K5, K6

- Electric Actuated
- Accepts 0-10vDC, 4-20mA or 0-135 ohm signal
- Spring Return to Fail Safe Position
- Manual Override
- NEMA 1 Enclosure
- Powder Coated Die Cast Aluminum Housing

ELECTRO-PNEUMATIC (I/P) TRANSDUCER

- Converts Current Signal to Pneumatic Signal
- Handles up to 150 PSIG Supply Air
- Accommodates 4-20 mA and 10-50 mA Input Signals

SPECIFICATION

Electro-pneumatic Transducer shall convert 4-20 mA or 10-50 mA input signals to a proportional 3-15 PSIG pneumatic output. Output capacity shall be a minimum of 17 SCFM with a 20 PSIG supply or 47 SCFM with a 120 PSIG supply.

MATERIALS OF CONSTRUCTION

Housing	Aluminum
Orifice	Sapphire
Nozzle	Bronze
PC Board	Fiberglass
Cover	Aluminum

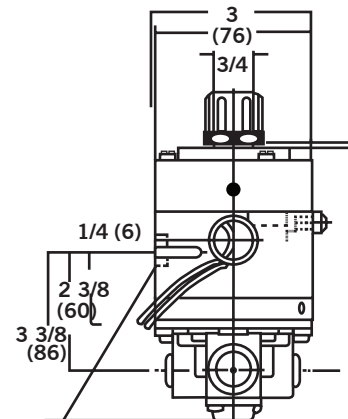

- (2) STANDOFFS
- (2) MOUNTING HOLES
- #10-32 UMF-2

ELECTRO-PNEUMATIC TRANSDUCER

APPLICATION DATA

- Simple way to control pneumatic valves with current signal

CONTROL VALVES

RTD RESISTANCE PROBE THERMOMETER

- 304 SS closed end probe measures temperature
- Varies electrical resistance in proportion to temperature changes
- Communicates change in resistance to automated systems

OPTIONS

- 304 SST Thermowell

SPECIFICATION

The RTD shall have a 304 stainless steel closed end probe with a 1/2 inch NPT male with hex fitting process connection. The RTD shall change resistance in proportion to a change in temperature and be capable of connecting to a device (such as a signal conditioning card) which can convert that resistance change to a standard 4-20 mA signal.

MATERIALS OF CONSTRUCTION

Connector Head: NB 1 Cast Iron
 Probe 304 SS Closed End
 Process Connection: 1/2" NPT Male with Hex fitting
 Electrical Connection: 1/2" NPT Female
 Sheath Length 5 1/2" or 11 1/2"
 Sheath Diameter 1/4"



RTD RESISTANCE PROBE THERMOMETER

APPLICATION DATA

- Building control systems
- Process control systems
- Systems utilizing the EPC Electro Pneumatic controller

ELECTRONIC PRESSURE TRANSMITTER



ELECTRONIC PRESSURE TRANSMITTER

APPLICATION DATA

- Building control systems
- Process control systems
- Systems utilizing the EPC Electro Pneumatic controller

- Solid state, calibrated transmitter measures pressure to $\pm 0.5\%$ accuracy
- Outputs 4-20 mA signal; 10-30 VDC unregulated; 100 ohms output impedance
- Integral metal diaphragm and polysilicon bridge are virtually unaffected by shock, vibration or mounting
- Available in ranges 0-30, 0-300 and 0-1000 psig, overpressure protected
- NEMA 4 compliant with cable or waterproof connector
- Operates in 40-200°F
- 1/8 NPT male or female process connection

SPECIFICATION

The Electronic Pressure Transmitter shall have a 1/8 NPT male or female 316 stainless steel process connection. The Electronic Pressure Transmitter shall measure pressure to $\pm 0.5\%$ accuracy and output a standard 4-20 mA signal with 100 ohms output impedance. The Electronic Pressure Transmitter shall be shock and vibration resistant, overpressure protected, operate within 40-200°F and be NEMA 4 compliant.

MATERIALS OF CONSTRUCTION

Case: 304 SS
 Diaphragm: 17-4 PH SS
 Process Connection: 316 SS

ECKARDT POSITIONER



ECKARDT PNEUMATIC POSITIONER WITH GAUGES

- Pneumatic or Electro-Pneumatic
- Modular Design
- Boost Adjustable
- Separate Control for Zero Point and Range of Travel

OPTIONS

- Gages

MODELS

P6981 Pneumatic Positioner

EP6986 Electro-pneumatic Positioner

SPECIFICATION

The positioner shall be SIRA and WIB approved and shall be mounted directly onto the valve. Feedback, 1/P Transducer and/or Limit Switch options shall be available.

APPLICATION DATA

- Control of Control Valve
- Split Range for Parallel Stations
- Fine Tune Control
- Where Required Air Pressure is Greater than Controller Output
- Where Change of Actuator Action is Desired (Reverse to Direct and vice versa)

RATINGS

Temperature Range	-40 to 176°F (-40 to 80°C)
Pneumatic Connections	1/4" NPT
Supply Pressure	60 psig
Air Consumption	0.11 to 0.21 SCFM
Input Signal	3-15 psig, Split Range, 4-20mA*
Hysteresis	≤0.3%
Body Construction	Aluminum

APPLICABLE CODES

SIRA and WIB Approved

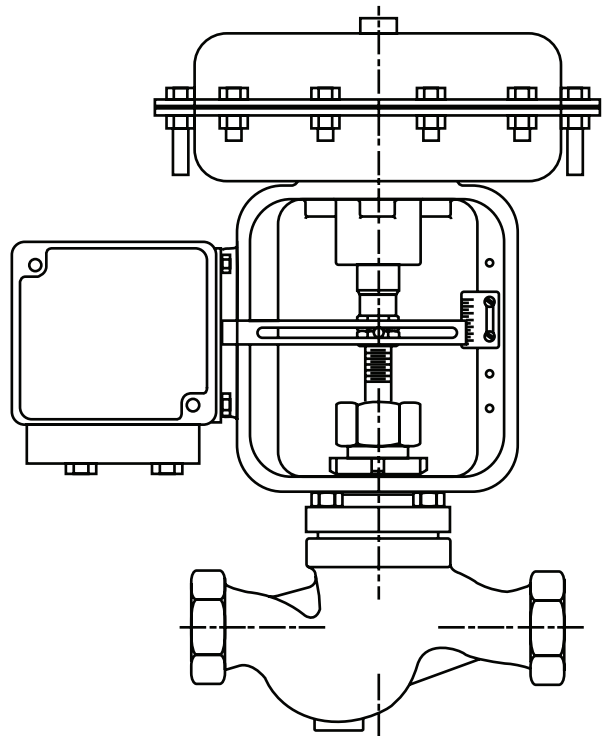

ECKARDT P6981 POSITIONER ON TYPE J CONTROL VALVE

*Applies to EP6986 only

PMV POSITIONER



APPLICATION DATA

- Control of Control Valves
- Split Range for Parallel Stations
- Fine Tune Control
- Where Required Air Pressure is Greater than Controller Output
- Where Change of Actuator Action is Desired (Reverse to Direct and vice versa)

RATINGS

Temperature Range	-4 to 185°F (-20 to 85°C)
Supply Pressure	60 psig
Air Consumption	0.31 SCFM (P4) 0.71 SCFM (P5) 0.78 SCFM (EP5)
Input Signal	3-15 psig, Split Range 4-20 mA
Linearity	±0.7% (P4) 0.5% (P5 & EP5)
Hysteresis	0.8% (P4) 0.75% (P5) 0.5% (EP5)
Body Construction	Aluminum

APPLICABLE CODES

CENELEC, FM and CSA approved

- Pneumatic or Electro-Pneumatic
- Compact, Rugged Design
- Easy to Calibrate
- Bright, Visible Indicator
- Low Air Consumption
- Mounts Compactly on Valve
- Stainless Steel Cam
- External Zero Adjustment
- Modular Design

OPTIONS

- Mechanical Limit Switch
- Proximity Limit Switch
- 4-20 mA Position Transmitter Feedback
- Potentiometer 1K Feedback
- Gauges

MODELS

P5 Pneumatic Positioner with Gauges

EP5 Electro-pneumatic Positioner with Gauges

SPECIFICATION

The Positioner shall be modular and cam characterized with FM, CSA and CENELEC certifications and shall be mounted directly onto the valve. Feedback, I/P Transducer and/or Limit Switch options shall be available

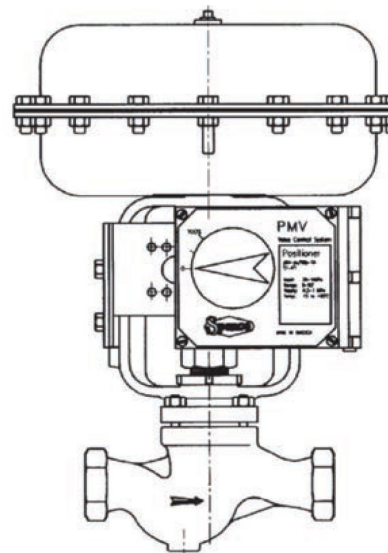

**PMV POSITIONER
ON TYPE J CONTROL VALVE**

MOORE POSITIONER

- Pneumatic or Electro-Pneumatic
- Modular Design
- Cam Characterized for Added Turndown
- Gauges Included
- Proportional Control
- Easy to Calibrate
- Non-Interacting Zero and Span
- Mounts compactly on Valve
- Provides Precise Control

OPTIONS.....

- Mechanical Limit Switch
- Proximity Limit Switch
- 4-20 mA Position Transmitter Feedback
- Potentiometer 1K Feedback

MODELS.....

760P Pneumatic Positioner

760EP Electro-pneumatic Positioner with Integral I/P Transducer

SPECIFICATION.....

The Positioner shall be modular and cam characterized with NEMA 4X, FM, CSA, CENELEC and Sira certifications and shall be mounted directly onto the valve. Feedback, I/P Transducer and/or Limit Switch options shall be available. The Positioner shall include gauges, have non-interacting zero and span and consume 0.5 to 0.6 SCFM.

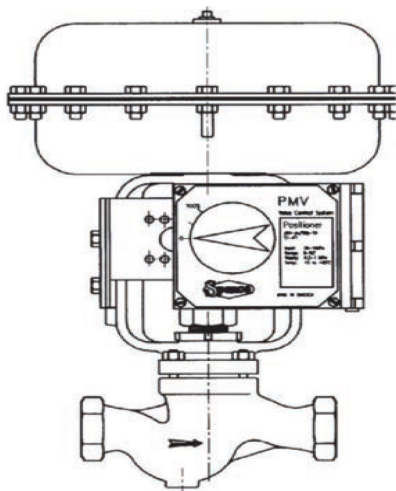

**MOORE 760P POSITIONER
ON TYPE J CONTROL VALVE**



MOORE 760P PNEUMATIC POSITIONER

APPLICATION DATA

- Control of Control Valves
- Split Range for Parallel Stations
- Fine Tune Control
- Where Required Air Pressure is Greater than Controller Output
- Where Change of Actuator Action is Desired (Reverse to Direct and vice versa)

RATINGS

Temperature Range	-40 to 185°F (-40 to 85 °C)
Pneumatic Connections	1/4" NPT
Gauge Connections	1/8" NPT
Electrical Connections	3/4" NPT
Exhaust Connections	1/4" NPT
Action	Direct or Reverse
Supply Pressure	60 psig
Air Consumption, Typical	0.5 SCFM
Input Signal	3-15 psig, Split Range, 4-20 mA*
Span	Adjustable, -60% to +25% of normal
Zero	Adjustable, -10% to +60% of normal
Linearity, Typical	0.5% of normal span 0.75% of normal span*
Hysteresis, Typical	0.75% of normal span 1.0% of normal span*
Dead band	0.25% of span

APPLICABLE CODES

NEMA 4X, IP 65

FM, CSA, CENELEC, Sira Approved

*Applies to 760EP only

CONTROL VALVE SIZING

VALVE SIZING BY COMPUTATION

C_v = Valve flow coefficient
 D = Nominal pipe size, inches
 d_p = Nominal Valve size, inches
 F_L = Pressure recovery factor, Liquid (See valve page)

F_p = Piping geometry factor, which is a capacity correction factor for a valve with reduced inlet and expanded outlet piping of the same size or a valve with expanded outlet piping only. (See table on facing page.)

$$= \frac{1}{\sqrt{\sum k C_v^2}} + 1$$

F_R = Valve Reynolds Number factor
 = 1 if $C_v > 0.1$ and viscosity < 1000 cs.
 (consult factory for other applications)

G = Specific gravity of liquid at flowing temperature

K = Specific heat ratio (see table)
 C_p = Specific heat at constant pressure
 C_v = Specific heat at constant volume

M = Molecular weight (See table)

P_1 = Initial fluid pressure psia

$= [p_1 \text{ (psig)} + 14.7]$
 P_2 = Reduced fluid pressure psia
 $= [p_2 \text{ (psig)} + 14.7]$
 P_c = Critical pressure of liquid
 (water = 3206 psia)
 P_v = Vapor pressure of liquid at inlet temperature
 (water @ 60°F = 0.2563 psia)
 ΔP = Comparative fluid pressure factor

$$= P_1 - P_2$$

ΔP_c = Critical pressure drop (psi)
 $= P_1 - .96 P_v + .28 \sqrt{\frac{P_v^3}{P_c}}$

Q = Flow - SCFM or GPM

T_1 = Initial absolute temperature of gas
 $= [t_1 \text{ (°F)} + 460]$

W = Flow - lb/hr

X_T = Pressure recovery factor, Gas (See valve page)

Z = Compressibility factor (Typically = 1)

$\sum k$ = Valve/piping friction factor
 $1.5 \left(1 - \frac{d^2}{D^2} \right)^2$

STEAM MASS

$$C_v = \frac{W}{19.3 F_p P_1 Y F_R} \sqrt{\frac{T_1 Z}{X M}}$$

GAS (VOLUME)

$$C_v = \frac{Q}{7320 F_p P_1 Y F_R} \sqrt{\frac{T_1 M Z}{X}}$$

SUBCRITICAL FLOW

$$\text{If } X < \frac{X_T K}{1.4}$$

$$X = \frac{\Delta P}{P_1} = \frac{P_1 - P_2}{P_1}$$

$$Y = 1 - \frac{X}{2.14 X_T K}$$

$$\text{if } X \geq \frac{X_T K}{1.4}$$

$$X = \frac{X_T K}{1.4}$$

$$Y = .667$$

CRITICAL FLOW

LIQUID (VOLUME)

SUBCRITICAL FLOW CRITICAL FLOW

$$\text{IF } \Delta P < \Delta P_c F_L^2$$

$$\text{IF } \Delta P \geq \Delta P_c F_L^2$$

$$C_v = \frac{Q}{F_p F_R \sqrt{\Delta P}} \sqrt{\frac{G}{\Delta P}}$$

$$C_v = \frac{Q}{F_L F_p F_R \sqrt{\Delta P}} \sqrt{\frac{G}{\Delta P}}$$

AVERAGE OF K & M TABLE

	K	M
Air	1.4	29
Nitrogen	1.404	28
Oxygen	1.401	32
Hydrogen	1.41	2
Carbon Dioxide	1.304	44
Steam	1.31	18.3

TYPE J PIPING GEOMETRY FACTORS

F_p
for Expanded Outlet Only

d/D	Valve Size	1/2		3/4			1				1 1/2			2		
	Port Size	1/4	5/8	1/4	5/8	7/8	1/4	5/8	7/8	1 1/4	7/8	1 1/4	1 3/4	1 1/4	1 3/4	2 1/4
1		1.0	1.0	1.0	1.0	1.0	1.0	1.0	1.0	1.0	1.0	1.0	1.0	1.0	1.0	1.0
.9		1.0	1.03	1.0	1.01	1.04	1.0	1.0	1.02	1.06	1.0	1.01	1.04	1.0	1.02	1.05
.8		1.0	1.05	1.0	1.02	1.07	1.0	1.01	1.04	1.09	1.01	1.02	1.06	1.01	1.03	1.07
.7		1.0	1.05	1.0	1.02	1.07	1.0	1.01	1.04	1.1	1.01	1.02	1.06	1.01	1.03	1.08
.6		1.0	1.05	1.0	1.02	1.07	1.0	1.01	1.04	1.09	1.01	1.02	1.06	1.01	1.03	1.07
.5		1.0	1.04	1.0	1.02	1.05	1.0	1.0	1.03	1.07	1.01	1.02	1.05	1.01	1.02	1.06
.4		1.0	1.03	1.0	1.01	1.04	1.0	1.0	1.02	1.05	1.0	1.01	1.03	1.0	1.01	1.04
.3		1.0	1.02	1.0	1.01	1.02	1.0	1.0	1.01	1.03	1.0	1.01	1.02	1.0	1.01	1.02

F_p
for Reduced Inlet and Expanded Outlet of the Same Size

d/D	Valve Size	1/2		3/4			1				1 1/2			2		
	Port Size	1/4	5/8	1/4	5/8	7/8	1/4	5/8	7/8	1 1/4	7/8	1 1/4	1 3/4	1 1/4	1 3/4	2 1/4
1		1.0	1.0	1.0	1.0	1.0	1.0	1.0	1.0	1.0	1.0	1.0	1.0	1.0	1.0	1.0
.9		1.0	.995	1.0	.997	.993	1.0	.999	.996	.992	.999	.998	.994	.999	.997	.992
.8		.998	.981	.999	.991	.976	1.0	.997	.987	.971	.997	.992	.978	.997	.989	.974
.7		.997	.963	.999	.983	.953	.999	.993	.974	.945	.994	.984	.958	.993	.978	.95
.6		.995	.945	.998	.974	.929	.999	.989	.96	.917	.991	.976	.936	.99	.967	.925
.5		.993	.926	.998	.965	.906	.999	.985	.947	.891	.988	.967	.915	.986	.955	.90
.4		.991	.91	.997	.956	.886	.999	.981	.935	.868	.985	.96	.897	.983	.944	.88
.5		.99	.897	.997	.95	.87	.999	.979	.925	.85	.982	.953	.882	.98	.936	.862

LINEAR VALVE SPECIFICATION FORM

	Project/Job Unit/customer P.O./LCO File # item Contract MFR Serial#	Data Sheet of..... Spec Tag Dwg Service																												
Fluid <input type="checkbox"/> Steam <input type="checkbox"/> Water <input type="checkbox"/> Gas <input type="checkbox"/> Liquid		Crit Pres PC																												
Service Conditions Flow <input type="checkbox"/> #/hr <input type="checkbox"/> gpm <input type="checkbox"/> scfh <input type="checkbox"/> Inlet pressure <input type="checkbox"/> psig <input type="checkbox"/> psia <input type="checkbox"/> Outlet pressure <input type="checkbox"/> psig <input type="checkbox"/> psia <input type="checkbox"/> Temperature <input type="checkbox"/> °C <input type="checkbox"/> °F <input type="checkbox"/> Max Press/Temperature:...../..... Density/MW/SG:...../...../..... Viscosity cP Vapor Pressure <input type="checkbox"/> psia <input type="checkbox"/> Required Cv Noise (dBA) Allowable		<table border="1" style="width: 100%; border-collapse: collapse;"> <thead> <tr style="background-color: #cccccc;"> <th style="padding: 5px;">Max.Flow</th> <th style="padding: 5px;">Norm.Flow</th> <th style="padding: 5px;">Min.Flow</th> <th style="padding: 5px;">shut-offpressure</th> </tr> </thead> <tbody> <tr><td style="height: 20px;"> </td><td> </td><td> </td><td> </td></tr> <tr><td style="height: 20px;"> </td><td> </td><td> </td><td> </td></tr> <tr><td style="height: 20px;"> </td><td> </td><td> </td><td> </td></tr> <tr><td style="height: 20px;"> </td><td> </td><td> </td><td> </td></tr> <tr><td style="height: 20px;"> </td><td> </td><td> </td><td> </td></tr> <tr><td style="height: 20px;"> </td><td> </td><td> </td><td> </td></tr> </tbody> </table>	Max.Flow	Norm.Flow	Min.Flow	shut-offpressure																								
Max.Flow	Norm.Flow	Min.Flow	shut-offpressure																											
Line Info Pipe Size In...../Sch..... Pipe Size Out...../Sch.....																														
Valve, Body and Bonnet Body Size <input type="checkbox"/> 1/2 <input type="checkbox"/> 3/4 <input type="checkbox"/> 1 <input type="checkbox"/> 1 1/2 <input type="checkbox"/> 2 <input type="checkbox"/> 2-1/2 <input type="checkbox"/> 3 <input type="checkbox"/> 4 <input type="checkbox"/> 6 <input type="checkbox"/> 8 <input type="checkbox"/> 10 <input type="checkbox"/> 12 ANSI Class <input type="checkbox"/> 120 <input type="checkbox"/> 150 <input type="checkbox"/> 250 <input type="checkbox"/> 300 <input type="checkbox"/> 600 <input type="checkbox"/> 900 <input type="checkbox"/> 1500 <input type="checkbox"/> 2500 <input type="checkbox"/> 4500 <input type="checkbox"/> Other Body/Bonnet Material: <input type="checkbox"/> Cast Iron <input type="checkbox"/> Cast Steel <input type="checkbox"/> Cr Mo <input type="checkbox"/> 316SS <input type="checkbox"/> Bronze <input type="checkbox"/> Hast C <input type="checkbox"/> Titanium <input type="checkbox"/> Alloy 20 <input type="checkbox"/> Other End Conn. Inlet/Outlet: <input type="checkbox"/> NPT <input type="checkbox"/> SWE <input type="checkbox"/> BWE Sch..... <input type="checkbox"/> Sep.Flanges <input type="checkbox"/> Int. Flanges <input type="checkbox"/> Other Packing Material: <input type="checkbox"/> PTEE <input type="checkbox"/> BTG <input type="checkbox"/> Laminated Graphite <input type="checkbox"/> Kalrez <input type="checkbox"/> Other																														
Trim Size <input type="checkbox"/> 100% <input type="checkbox"/> 60% <input type="checkbox"/> 40% <input type="checkbox"/> 20% <input type="checkbox"/> Other																														
Actuator Spring Action: <input type="checkbox"/> Air to Open <input type="checkbox"/> Air to Close <input type="checkbox"/> Last Position <input type="checkbox"/> None Available Air Supply Pressure: <input type="checkbox"/> Max <input type="checkbox"/> Min Manual Override: <input type="checkbox"/> Yes <input type="checkbox"/> No <input type="checkbox"/> Type																														
Solenoid <input type="checkbox"/> Yes <input type="checkbox"/> No <input type="checkbox"/> Type <input type="checkbox"/> Voltage																														
Positioner <input type="checkbox"/> Yes <input type="checkbox"/> No <input type="checkbox"/> Type <input type="checkbox"/> Pneu <input type="checkbox"/> I/P																														
Switch <input type="checkbox"/> Yes <input type="checkbox"/> No <input type="checkbox"/> Type																														
Air Set <input type="checkbox"/> Yes <input type="checkbox"/> No <input type="checkbox"/> Type..... <input type="checkbox"/> Range.....																														
Other Accessories <input type="checkbox"/> Yes <input type="checkbox"/> No <input type="checkbox"/> Type.....																														
Test ANSI/FCI Leakage Class: <input type="checkbox"/> II <input type="checkbox"/> III <input type="checkbox"/> IV <input type="checkbox"/> V <input type="checkbox"/> VI <input type="checkbox"/> Leslie VIII																														

CONTROL VALVE SIZING

**SECTION III
SEPARATORS,
DESUPERHEATERS AND
NOISE REDUCTION**

ELIMINATOR SERIES STEAM AND AIR SEPARATOR

Pressures to 990 PSIG (68.2 barg) /
Temperatures to 750°F (344°C)



STEAM SEPARATOR

APPLICATION DATA

- Steam, compressed air and gas systems
- Steam mains
- Before steam turbines
- Hot air batteries
- Duplicators
- Boilers
- Kilns
- Radiators
- Sterilizers
- Drip stations before temperature control or pressure-reducing valves
- Steam inlets to process equipment which require dry saturated steam
- Before filters and on the compressed air supply to sensitive instruments
- Laundry Processes

Installation Tip: Always install a Steam Trap (i.e.: NFT, FTN, Max-Flo, Dura-Flo) after the Steam Separator.

Always install a Y Strainer between the Steam Separator and Trap.

- **Removal of Entrained Contaminants** – Extracts nearly all moisture and solids above 10 microns
- **Long Service Life** – No moving parts mean less wear and corrosion
- **High Capacities** – Up to 35,000 lbs/hr steam
- **Steel bodies and internals** – Withstand unfavorable conditions and water hammer
- **Drain Outlet Below Condensate Level** – Prevents steam leakage
- **Optimal Gravity Discharge** – Drain located directly below the line
- **Maintenance Free** – Regular maintenance is not required
- **Steam of Air Service**

OPTIONS

- Optional Insulation Jacket

MAXIMUM OPERATING CONDITIONS

- 1/2" - 2" NPT and SW
Class 400 - 990 psig (68.2 barg) @ 100°F (34°C)
- 2-1/2" - 6" ANSI 150 Flanged
Class 150 - 285 psig (19.6 barg) @ 100°F (34°C)
- 2-1/2" - 6" ANSI 300 Flanged
Class 300 - 740 psig (51.0 barg) @ 100°F (34°C)
- 2-1/2" - 6" ANSI 600 Flanged
Class 400 - 990 psig (68.2 barg) @ 100°F (34°C)

MODELS

- ES-150 - 150 psig ANSI Flanged
- ES-300 - 300 psig ANSI Flanged
- ES-600 - 600 psig NPT, Socketweld, ANSI Flanged

NOTE: This is a fabricated product. Custom designs are available. Please call factory for details.

OPERATION

When the vapor enters the steam separator, a series of baffles change its flow direction several times. During this process, the baffles in the housing collect impinged water droplets that are carried in the system.

Gravity allows the accumulated water droplets and other foreign particles to fall to the system through a steam trap. The remaining steam in the system is clean and dry, allowing improved and maintained performance.

ELIMINATOR SERIES STEAM AND AIR SEPARATOR

SPECIFICATION

Steam Separator should have an internal baffle that does not exceed an equivalent length of pipe. The Steam Separator should be installed in a horizontal pipe configuration with the drain directly below the line. The Steam Separator should have an NPT bottom drain on which a mechanical constant flow steam trap shall be installed.

MATERIALS OF CONSTRUCTION

Body	(1/2" to 2") Carbon Steel	ASTM SA53
	(2-1/2" to 6) Carbon Steel	ASTM SA53
End Caps	Carbon Steel	ASTM A-234 WPB
Coupling	Carbon Steel	ASTM A105
Baffle	Carbon Steel	ASTM SA53
	Stainless Steel	Optional
Plug	Carbon Steel	ASTM A105
End Connections:	(1/2" to 2") Carbon Steel	ASTM A105
	(2-1/2" to 6) Carbon Steel	ASTM A105

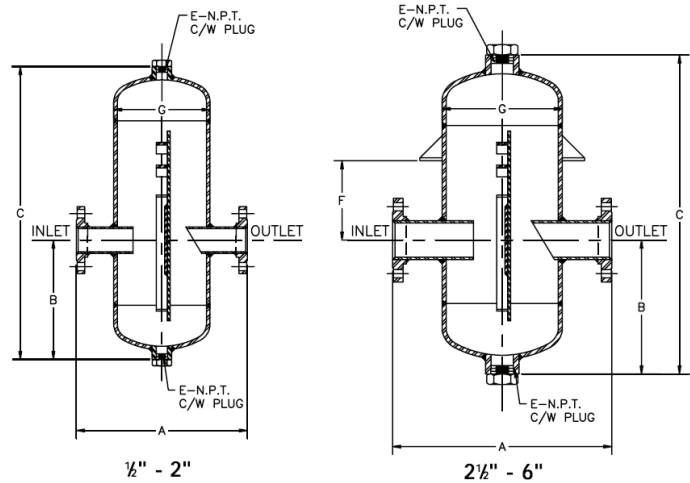

CONNECTIONS

1/2" - 2" SW and NPT or 2-1/2" - 6" Flanged

Call Factory for sizing information. Please provide the following:

1. Steam or Compressed Air System
2. Flow Rate (lb/hr) _____
3. Separator Connection Size _____
4. System Pressure _____

DIMENSIONS INCHES (MM) AND WEIGHTS POUNDS (KG)

PIPE SIZE	CONNECTION	A	B	C	E	F	G	WEIGHT
1/2	NPT/SW	3-5/8 (218)	5-1/4 (132)	10-5/8 (269)	3/4 (20.3)	—	6 (152.4)	9 (4.1)
		8-3/4 (224)	5-7/8 (150)	12-1/8 (307)	3/4 (20.3)	—	6 (152.4)	10 (4.5)
1	NPT/SW	9-1/4 (236)	6 (152)	14-1/8 (358)	3/4 (20.3)	—	6 (152.4)	19 (8.6)
1-1/4	NPT/SW	9-3/8 (238)	7-1/8 (180)	16-3/8 (416)	3/4 (20.3)	—	6 (152.4)	30 (13.6)
1-1/2	NPT/SW	11-1/8 (287)	7-5/8 (193)	19 (483)	1 (25.4)	—	8 (203)	43 (19.5)
2	NPT/SW	11-5/8 (295)	11-1/8 (206)	20-5/8 (523)	1 (25.4)	—	8 (203)	50 (22.7)
2-1/2	Flanged ANSI 150	22-1/2 (572)	9-3/8 (239)	24-1/2 (622)	1 (25.4)	7-1/8 (180)	10 (254)	109 (49.4)
	Flanged ANSI 300	22-1/2 (572)	9-3/8 (239)	24-1/2 (622)	1 (25.4)	7-1/2 (180)	10 (254)	112 (50.8)
	Flanged ANSI 600	22-1/2 (572)	9-3/8 (239)	25-5/8 (650)	1 (25.4)	7-1/2 (180)	10 (254)	113 (51.3)
3	Flanged ANSI 150	25-1/4 (643)	12 (305)	28-5/8 (726)	2 (50.8)	8 (203)	10 (254)	163 (73.9)
	Flanged ANSI 300	25-1/4 (643)	12 (305)	28-3/4 (732)	2 (50.8)	8 (203)	10 (254)	169 (76.7)
	Flanged ANSI 600	25-1/4 (643)	12-3/4 (323)	29-7/8 (759)	2 (50.8)	8 (203)	10 (254)	189 (85.7)
4	Flanged ANSI 150	29 (737)	12-5/8 (320)	31-1/4 (792)	2 (50.8)	8 (203)	12 (305)	237 (108)
	Flanged ANSI 300	29 (737)	12-5/8 (320)	31-1/4 (792)	2 (50.8)	8 (203)	12 (305)	256 (116)
	Flanged ANSI 600	29 (737)	13-1/4 (335)	31-1/4 (792)	2 (50.8)	8 (203)	12 (305)	297 (135)
6	Flanged ANSI 150	35-3/4 (909)	12-1/4 (312)	36-3/4 (932)	2 (50.8)	11-3/8 (290)	16 (406)	365 (166)
	Flanged ANSI 300	35-3/4 (909)	12-3/8 (315)	36-7/8 (937)	2 (50.8)	11-3/8 (290)	16 (406)	401 (182)
	Flanged ANSI 600	35-3/4 (909)	13 (330)	37-3/4 (960)	2 (50.8)	11-3/8 (290)	16 (406)	551 (250)

SIZING ELIMINATOR STEAM SEPARATORS

SIZING FOR STEAM APPLICATIONS

Using your system pressure and capacity, select a size from the Pressure Drop Tables below that will yield a pressure drop in **boldface** type. This will provide the most efficient separation with velocities between 30 and 100 ft/s for sizes up to 2-1/2" and between 30 and 90 ft/s for sizes 3" and above.

EXAMPLE

For a system under 400 psig with a capacity of 500 #/hr, a 1/2" or 3/4" separator is recommended.

- a. A 1/2" separator will provide a 1.86 psig pressure drop.
- b. A 3/4" separator will provide a 0.59 psig pressure drop.

ELIMINATOR PRESSURE DROP TABLES – STEAM

1/2 INCH ELIMINATOR

#/HR	PRESSURE (PSIG)								
	25	50	75	100	200	300	400	500	600
100	0.71	0.45	0.33	0.26	0.15	0.1	0.07	0.06	0.05
200	2.83	1.8	1.32	1.05	0.62	0.39	0.3	0.24	0.2
300	6.37	4.04	2.97	2.36	1.39	0.88	0.67	0.54	0.46
400	11.33	7.18	5.28	4.19	2.47	1.56	1.19	0.96	0.81
500	17.7	11.22	8.26	6.55	3.86	2.44	1.86	1.5	1.27
600	25.49	16.16	11.89	9.43	5.55	3.52	2.69	2.16	1.82

1 INCH ELIMINATOR

#/HR	PRESSURE (PSIG)								
	25	50	75	100	200	300	400	500	600
300	0.76	0.48	0.35	0.28	0.17	0.1	0.08	0.06	0.05
500	2.11	1.34	0.98	0.78	0.46	0.29	0.22	0.18	0.15
700	4.13	2.62	1.93	1.53	0.9	0.57	0.44	0.35	0.3
900	6.83	4.33	3.19	2.53	1.49	0.94	0.72	0.58	0.49
1100	10.21	6.47	4.76	3.78	2.22	1.41	1.08	0.87	0.73
1300	14.26	9.04	6.65	5.27	3.11	1.97	1.5	1.21	1.02
1500	18.98	12.03	8.85	7.02	4.14	2.62	2	1.61	1.36

1-1/2 INCH ELIMINATOR

#/HR	PRESSURE (PSIG)								
	25	50	75	100	200	300	400	500	600
400	0.24	0.15	0.11	0.09	0.05	0.03	0.03	0.02	0.02
500	0.37	0.24	0.17	0.14	0.08	0.05	0.04	0.03	0.03
1000	1.49	0.95	0.7	0.55	0.33	0.21	0.16	0.13	0.11
2000	5.98	3.79	2.79	2.21	1.3	0.82	0.63	0.51	0.43
3000	13.45	8.52	6.27	4.97	2.93	1.86	1.42	1.14	0.96
4000	23.91	15.16	11.15	8.84	5.21	3.3	2.52	2.03	1.71

2-1/2 INCH ELIMINATOR

#/HR	PRESSURE (PSIG)								
	25	50	75	100	200	300	400	500	600
1000	0.27	0.17	0.12	0.1	0.06	0.04	0.03	0.02	0.02
2000	1.07	0.68	0.5	0.39	0.23	0.15	0.11	0.09	0.08
3000	2.4	1.52	1.12	0.89	0.52	0.33	0.25	0.2	0.17
4000	4.27	2.71	1.99	1.58	0.93	0.59	0.45	0.36	0.31
5000	6.68	4.23	3.11	2.47	1.45	0.92	0.7	0.57	0.48
6000	9.61	6.09	4.48	3.55	2.09	1.33	1.01	0.82	0.69
7000	13.08	8.29	6.1	4.84	2.85	1.81	1.38	1.11	0.94

4 INCH ELIMINATOR

#/HR	PRESSURE (PSIG)								
	25	50	75	100	200	300	400	500	600
4000	0.6	0.38	0.28	0.22	0.13	0.08	0.06	0.05	0.04
6000	1.34	0.85	0.63	0.5	0.29	0.19	0.14	0.11	0.1
8000	2.39	1.51	1.11	0.88	0.52	0.33	0.25	0.2	0.17
10000	3.73	2.37	1.74	1.38	0.81	0.51	0.39	0.32	0.27
12000	5.37	3.41	2.51	1.99	1.17	0.74	0.57	0.46	0.38
14000	7.32	4.64	3.41	2.71	1.59	1.01	0.77	0.62	0.52
16000	9.55	6.06	4.46	3.53	2.08	1.32	1.01	0.81	0.68

3/4 INCH ELIMINATOR

#/HR	PRESSURE (PSIG)								
	25	50	75	100	200	300	400	500	600
100	0.22	0.14	0.1	0.08	0.05	0.03	0.02	0.02	0.02
200	0.89	0.57	0.42	0.33	0.19	0.12	0.09	0.08	0.06
300	2.01	1.27	0.94	0.74	0.44	0.28	0.21	0.17	0.14
400	3.57	2.26	1.66	1.32	0.78	0.49	0.38	0.3	0.25
500	5.57	3.53	2.6	2.06	1.21	0.77	0.59	0.47	0.4
600	8.02	5.09	3.74	2.97	1.75	1.11	0.85	0.68	0.57

1-1/4 INCH ELIMINATOR

#/HR	PRESSURE (PSIG)								
	25	50	75	100	200	300	400	500	600
500	0.69	0.44	0.32	0.26	0.15	0.1	0.07	0.06	0.05
750	1.56	0.99	0.73	0.58	0.34	0.22	0.16	0.13	0.11
1100	3.36	2.13	1.57	1.24	0.73	0.46	0.35	0.29	0.24
1250	4.34	2.75	2.02	1.6	0.95	0.6	0.46	0.37	0.31
1500	6.25	3.96	2.91	2.31	1.36	0.86	0.66	0.53	0.45
1750	8.5	5.39	3.97	3.14	1.85	1.17	0.9	0.72	0.61
2000	11.11	7.04	5.18	4.11	2.42	1.53	1.17	0.94	0.79

2 INCH ELIMINATOR

#/HR	PRESSURE (PSIG)								
	25	50	75	100	200	300	400	500	600
1000	0.54	0.34	0.25	0.2	0.12	0.07	0.06	0.05	0.04
2000	2.17	1.37	1.01	0.8	0.47	0.3	0.23	0.18	0.16
3000	4.88	3.09	2.28	1.8	1.06	0.67	0.51	0.41	0.35
4000	8.67	5.5	4.04	3.21	1.89	1.2	0.91	0.74	0.62
5000	13.55	8.59	6.32	5.01	2.95	1.87	1.43	1.15	0.97
6000	19.51	12.37	9.1	7.22	4.25	2.69	2.06	1.66	1.4

3 INCH ELIMINATOR

#/HR	PRESSURE (PSIG)								
	25	50	75	100	200	300	400	500	600
2000	0.45	0.28	0.21	0.17	0.1	0.06	0.05	0.04	0.03
4000	1.79	1.13	0.83	0.66	0.39	0.25	0.19	0.15	0.13
6000	4.02	2.55	1.87	1.49	0.88	0.55	0.42	0.34	0.29
8000	7.15	4.53	3.33	2.64	1.56	0.99	0.75	0.61	0.51
10000	11.17	7.08	5.21	4.13	2.43	1.54	1.18	0.95	0.8
12000	16.08	10.19	7.5	5.95	3.5	2.22	1.69	1.37	1.15
14000	21.89	13.87	10.21	8.09	4.77	3.02	2.31	1.86	1.56

6 INCH ELIMINATOR

#/HR	PRESSURE (PSIG)								
	25	50	75	100	200	300	400	500	600
5000	0.18	0.11	0.08	0.07	0.04	0.02	0.02	0.02	0.01
10000	0.72	0.46	0.33	0.27	0.16	0.1	0.08	0.06	0.05
15000	1.62	1.02	0.75	0.6	0.35	0.22	0.17	0.14	0.12
20000	2.87	1.82	1.34	1.06	0.63	0.4	0.3	0.24	0.21
25000	4.49	2.85	2.09	1.66	0.98	0.62	0.47	0.38	0.32
30000	6.46	4.1	3.01	2.39	1.41	0.89	0.68	0.55	0.46
35000	8.8	5.58	4.1	3.25	1.92	1.21	0.93	0.75	0.63

SEPA,
DESUPER,
, NOISE

SIZING ELIMINATOR STEAM SEPARATORS

SIZING FOR AIR APPLICATIONS

Using your system pressure and capacity, select a size from the Pressure Drop Tables below that will yield a pressure drop in **boldface** type. This will provide the most efficient separation with velocities between 8 and 60 ft/s for sizes up to 2-1/2" and between 8 and 50 ft/s for sizes 3" and above.

EXAMPLE

For a system under 400 psig with a capacity of 500 SCFM, a 2" or 2-1/2" separator is recommended.

- a. A 2" separator will provide a 0.12 psig pressure drop.
- b. A 2-1/2" separator will provide a 0.06 psig pressure drop.

ELIMINATOR PRESSURE DROP TABLES – AIR

1/2 INCH ELIMINATOR

SCFM	PRESSURE (PSIG)								
	25	50	75	100	200	300	400	500	600
10	0.07	0.04	0.03	0.02	0.01	0.01	0.01	0.01	0
20	0.27	0.17	0.12	0.09	0.05	0.03	0.03	0.02	0.02
30	0.61	0.37	0.27	0.21	0.11	0.08	0.06	0.05	0.04
40	1.08	0.66	0.48	0.37	0.2	0.14	0.1	0.08	0.07
50	1.69	1.03	0.75	0.58	0.31	0.21	0.16	0.13	0.11
60	2.43	1.49	1.07	0.84	0.45	0.31	0.23	0.19	0.16

1 INCH ELIMINATOR

SCFM	PRESSURE (PSIG)								
	25	50	75	100	200	300	400	500	600
25	0.05	0.03	0.02	0.02	0.01	0.01	0	0	0
50	0.2	0.12	0.09	0.07	0.04	0.03	0.02	0.02	0.01
75	0.45	0.28	0.2	0.16	0.08	0.06	0.04	0.03	0.03
100	0.8	0.49	0.36	0.28	0.15	0.1	0.08	0.06	0.05
125	1.26	0.77	0.56	0.43	0.23	0.16	0.12	0.1	0.08
150	1.81	1.11	0.8	0.63	0.33	0.23	0.17	0.14	0.12

1-1/2 INCH ELIMINATOR

SCFM	PRESSURE (PSIG)								
	25	50	75	100	200	300	400	500	600
50	0.04	0.02	0.02	0.01	0.01	0	0	0	0
100	0.14	0.09	0.06	0.05	0.03	0.02	0.01	0.01	0.01
150	0.32	0.2	0.14	0.11	0.06	0.04	0.03	0.02	0.02
200	0.57	0.35	0.25	0.2	0.11	0.07	0.05	0.04	0.04
250	0.89	0.55	0.39	0.31	0.16	0.11	0.09	0.07	0.06
300	1.28	0.79	0.57	0.44	0.24	0.16	0.12	0.1	0.08

2-1/2 INCH ELIMINATOR

SCFM	PRESSURE (PSIG)								
	25	50	75	100	200	300	400	500	600
100	0.03	0.02	0.01	0.01	0	0	0	0	0
250	0.16	0.1	0.07	0.06	0.03	0.02	0.02	0.01	0.01
500	0.64	0.39	0.28	0.22	0.12	0.08	0.06	0.05	0.04
750	1.43	0.88	0.63	0.5	0.26	0.18	0.14	0.11	0.09
1000	2.54	1.56	1.13	0.88	0.47	0.32	0.24	0.2	0.16
1250	3.97	2.44	1.76	1.38	0.73	0.5	0.38	0.31	0.26

4 INCH ELIMINATOR

SCFM	PRESSURE (PSIG)								
	25	50	75	100	200	300	400	500	600
250	0.02	0.01	0.01	0.01	0	0	0	0	0
500	0.09	0.05	0.04	0.03	0.02	0.01	0.01	0.01	0.01
1000	0.36	0.22	0.16	0.12	0.07	0.04	0.03	0.03	0.02
1500	0.8	0.49	0.35	0.28	0.15	0.1	0.08	0.06	0.05
2000	1.42	0.87	0.63	0.49	0.26	0.18	0.14	0.11	0.09
2500	2.22	1.36	0.98	0.77	0.41	0.28	0.21	0.17	0.14

3/4 INCH ELIMINATOR

SCFM	PRESSURE (PSIG)								
	25	50	75	100	200	300	400	500	600
10	0.02	0.01	0.01	0.01	0	0	0	0	0
25	0.13	0.08	0.06	0.05	0.02	0.02	0.01	0.01	0.01
50	0.53	0.33	0.23	0.18	0.1	0.07	0.05	0.04	0.03
70	1.04	0.64	0.46	0.36	0.19	0.13	0.1	0.08	0.07
90	1.72	1.05	0.76	0.59	0.32	0.22	0.16	0.13	0.11
110	2.57	1.58	1.14	0.89	0.47	0.32	0.25	0.2	0.17

1-1/4 INCH ELIMINATOR

SCFM	PRESSURE (PSIG)								
	25	50	75	100	200	300	400	500	600
50	0.07	0.04	0.03	0.02	0.01	0.01	0.01	0.01	0
100	0.26	0.16	0.12	0.09	0.05	0.03	0.03	0.02	0.02
150	0.59	0.37	0.26	0.21	0.11	0.08	0.06	0.05	0.04
200	1.06	0.65	0.47	0.37	0.2	0.13	0.1	0.08	0.07
250	1.65	1.01	0.73	0.57	0.31	0.21	0.16	0.13	0.11
300	2.38	1.46	1.05	0.82	0.44	0.3	0.23	0.18	0.15

2 INCH ELIMINATOR

SCFM	PRESSURE (PSIG)								
	25	50	75	100	200	300	400	500	600
100	0.05	0.03	0.02	0.02	0.01	0.01	0	0	0
200	0.21	0.13	0.09	0.07	0.04	0.03	0.02	0.02	0.01
300	0.46	0.29	0.21	0.16	0.09	0.06	0.04	0.04	0.03
400	0.83	0.51	0.37	0.29	0.15	0.1	0.08	0.06	0.05
500	1.29	0.79	0.57	0.45	0.24	0.16	0.12	0.1	0.08
600	1.86	1.14	0.82	0.64	0.34	0.23	0.18	0.14	0.12

3 INCH ELIMINATOR

SCFM	PRESSURE (PSIG)								
	25	50	75	100	200	300	400	500	600
200	0.04	0.03	0.02	0.01	0.01	0.01	0	0	0
400	0.17	0.1	0.08	0.06	0.03	0.02	0.02	0.01	0.01
600	0.38	0.23	0.17	0.13	0.07	0.05	0.04	0.03	0.02
800	0.68	0.42	0.3	0.24	0.13	0.09	0.07	0.05	0.04
1000	1.06	0.65	0.47	0.37	0.2	0.13	0.1	0.08	0.07
1200	1.53	0.94	0.68	0.53	0.28	0.19	0.15	0.12	0.1

6 INCH ELIMINATOR

SCFM	PRESSURE (PSIG)								
	25	50	75	100	200	300	400	500	600
500	0.02	0.01	0.01	0.01	0	0	0	0	0
1000	0.07	0.04	0.03	0.02	0.01	0.01	0.01	0.01	0
2000	0.27	0.17	0.12	0.09	0.05	0.03	0.03	0.02	0.02
3000	0.62	0.38	0.27	0.21	0.11	0.08	0.06	0.05	0.04
4000	1.09	0.67	0.48	0.38	0.2	0.14	0.1	0.08	0.07
5000	1.71	1.05	0.76	0.59	0.32	0.22	0.16	0.13	0.11

DESUPERHEATERS

DESUPERHEATERS

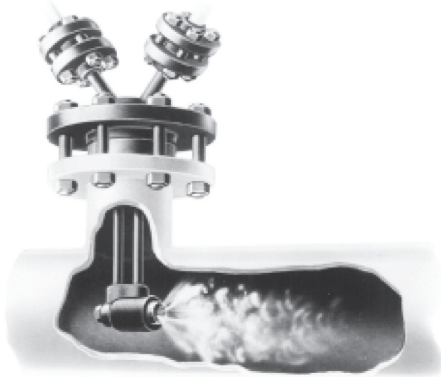

STEAM ATOMIZING DESUPERHEATER

PRESSURES to 600 PSIG at 750°F

- Reduces the temperature of superheated steam by controlled direct injection of cooling water
- Mechanical atomizing 2.5:1 turndown
- Steam atomizing 20:1 turndown
- Line Sizes 3" to 24" (larger sizes available upon request)
- Velocities to 8000 feet per minute
- Air operated only

CANADIAN REGISTRATION# OH6267.5RC

APPLICATION DATA

- Reduce Temperature of Superheated Steam

SIZING INFO PAGE 154

MECHANICAL ATOMIZING DIMENSIONS, inches (mm) AND WEIGHTS, pounds (kg)

Size Weight	B	H	K	A														
				P = MAIN STEAM PIPE														
				3	3 1/2	4	5	6	8	10	12	14	16	18	20	24		
#1	5 (127)	1/4 (6)	2 (51)	7 (178)	7-1/2 (191)	8-1/2 (216)	10 (254)	11 (280)	13 (330)	-	-	-	-	-	-	-	-	15 (6.8)
#3	4-1/2 (113)	1/2 (13)	2 (51)	-	-	8-1/2 (216)	10 (254)	11 (280)	13 (330)	15-1/2 (394)	16-1/2 (419)	-	-	-	-	-	-	22 (10)
#5	5-7/8 (149)	1 (25)	4 (102)	-	-	-	-	11 (280)	13 (330)	15-1/2 (394)	16-1/2 (419)	17-1/2 (445)	19-1/2 (495)	-	-	-	-	40 (18)
#6	7-1/2 (190)	1-1/4 (32)	4 (102)	-	-	-	-	-	13 (330)	15-1/2 (394)	16-1/2 (419)	17-1/2 (445)	19-1/2 (495)	21-1/2 (546)	-	-	-	75 (34)
#8	9-3/16 (233)	2 (51)	6 (152)	-	-	-	-	-	-	15-1/2 (394)	16-1/2 (419)	17-1/2 (445)	18-1/2 (470)	19-1/2 (495)	20-1/2 (521)	22-1/4 (565)	22-1/4 (565)	135 (61)

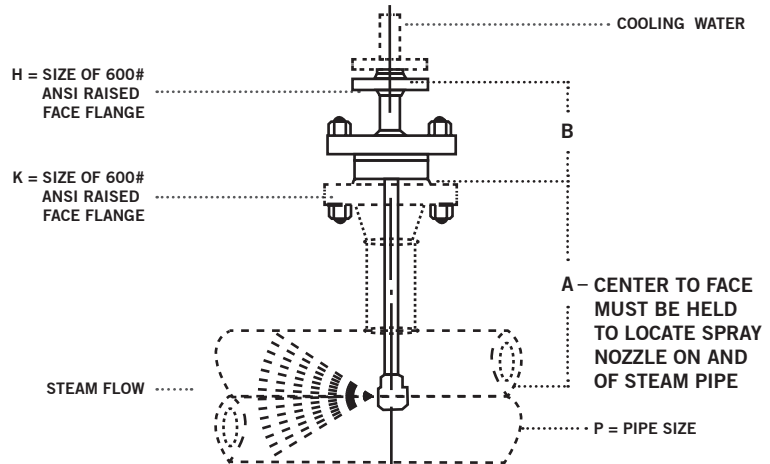
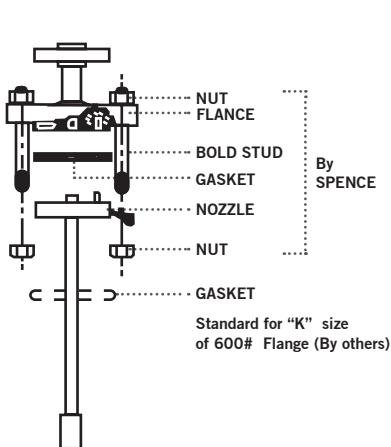

SEPA,
DESUPER,
NOISE

DESUPERHEATERS

SPECIFICATION

The Desuperheater shall be air operated, consisting of atomizing injector nozzle, dual controller, air pilot and strainers. It shall be capable of handling wide load variations from full load to 5% of maximum and control within $\pm 5^\circ\text{F}$.

The injector nozzle shall be designed and installed to disperse the minute water particles and atomizing steam counter to the flow of superheated steam, enabling the fine mist to be easily evaporated.

MATERIALS OF CONSTRUCTION

300 Series Stainless Steel

STEAM ATOMIZING DIMENSIONS, inches (mm) AND WEIGHTS, pounds (kg)

Size Weight	B	H	J	K	A														
					P = MAIN STEAM PIPE														
					3	3 1/2	4	5	6	8	10	12	14	16	18	20	24		
#1	5 (127)	1/4 (6)	3 3/4 (95)	2 (51)	7 (178)	7 1/2 (191)	8 1/2 (216)	10 (254)	11 (280)	13 (330)	-	-	-	-	-	-	-	-	18 (8)1
#3	5 1/4 (133)	1/2 (13)	2 1 1/16 (51)	2-1/2 (64)	-	-	8 1/2 (216)	10 (254)	11 (280)	13 (330)	15 1/2 (394)	16 1/2 (419)	-	-	-	-	-	-	28 (13)
#5	5 7/8 (148)	1 (25)	3 3/4 (95)	4 (102)	-	-	-	-	11 (280)	13 (330)	15 1/2 (394)	16 1/2 (419)	17 1/2 (445)	19 1/2 (495)	21 1/2 (546)	23 1/2 (597)	27 1/2 (699)	68 (31)	
#6	6 9/16 (243)	1 1/4 (32)	6 (152)	5 (127)	-	-	-	-	-	13 (330)	15 1/2 (394)	16 1/2 (419)	17 1/2 (445)	19 1/2 (495)	21 1/2 (546)	-	-	110 (50)	
#8	8 1/4 (210)	2 (51)	6 (152)	8 (203)	-	-	-	-	-	-	15 1/2 (394)	16 1/2 (419)	17 1/2 (445)	18 1/2 (470)	19 1/2 (495)	23 1/2 (597)	27 1/2 (699)	270 (123)	

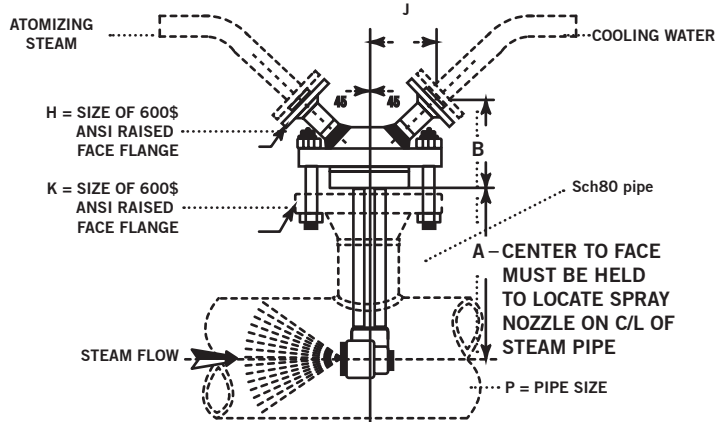
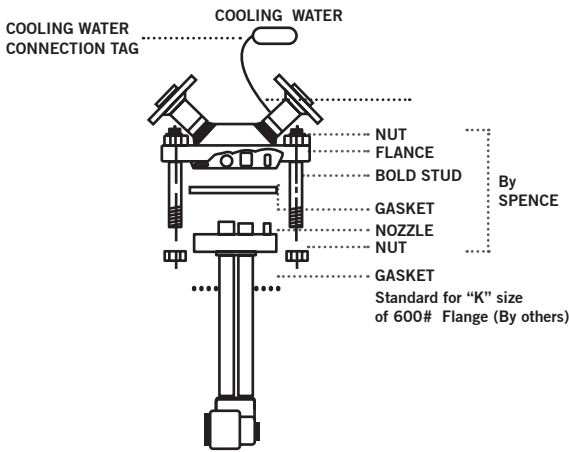

SEPA-
DESUPER-
NOISE

RULES FOR SIZING DESUPERHEATERS

The required amount of cooling water to be injected into the superheated steam is the basis on which a Desuperheater size is determined. Since the heat gained by the injected cooling water equals the heat lost by the superheated steam, the required cooling water, G, in gallons per minute is calculated as follows:

$$G = \frac{W_s}{500} \times \frac{h_s - h_d}{h_d - (t - 32)} \text{ gpm}$$

Where: W_s = Superheated steam flow, lb per hour

h_s = Total heat of the superheated steam, Btu per lb

h_d = Total heat of the desuperheated steam, Btu per lb

t = Temperature of the cooling water, °F

The values h_s and h_d may be taken from the Steam Tables from pages 106 and 107. Having determined the amount of cooling water, G, choice of the size unit may be made directly from the Selection table below.

Cooling water supply pressure must always be at least 75 psig higher than the pressure of the steam being desuperheated.

With Steam Atomizing Desuperheaters, the atomizing steam pressure must always be at least 50 psig higher than the pressure of the steam being desuperheated. Also, when there is more than approximately 100 psig difference between cooling water and atomizing steam pressures, a pressure reduction should be made on the higher of the two.

SELECTION TABLE-STEAM ATMOZING AND MECHANICAL ATMOZING DESUPERHEATERS

	J VALVE OPERATED			
SIZE NUMBER	No. 3	No. 5	No. 6	No. 8
COOLING WATER CAPACITY, GPM	4.0	12	22	52
PIPE CONNECTIONS FOR COOLING WATER AND ATMOZING STEAM	1/2"	1"	1 1/4"	2"
MINIMUM SIZE OF MAIN STEAM PIPE	4"	6"	8"	12"

A source of higher pressure atomizing steam offers no problem on most desuperheater installations. Generally, the steam being desuperheated is at reduced pressure, having either been throttled by a reducing valve or extracted from an intermediate stage of a turbine.

When a pressure reduction is required in conjunction with desuperheating the steam, it is recommended that the reduction take place prior to desuperheating for the following reasons:

1. Auxillary high pressure steam for atomization is immediately available
2. The pressure Regulator is not subject to a damaging accumulation of soluble salts precipitated by evaporation from the cooling water.
3. Elimination of resuperheating when the pressure reduction is after the point of superheat control.

If higher pressure steam is not available, a Mechanical Atomizing Desuperheater must be employed. The Injector Nozzle is identical with the Steam Atomizing Nozzle except that it does not have the advantage of secondary atomization into mist by the action of the steam.

NOISE REDUCTION

NOISE SUPPRESSOR



NOISE SUPPRESSORS

APPLICATION DATA

- Steam Pressure Reduction Stations where Noise Reduction is Desired

SUPPRESSOR ENDS

INLET ANSI	OUTLET ANSI
NPT.....	NPT
NPT.....	150#
NPT.....	300#
150#.....	150#
300#.....	150#
300#.....	300#

NOTE: ANSI 150# Flanges are flat faced.

It is recommended that the Noise Suppressor be insulated to reduce condensation formation in the acoustic material.

SIZING INFO PAGE 163

SERVICE to 500°F

- Standard sizes 3/8" to 8". Consult Factory for additional sizes
- Effective over a broad frequency band (up to 12,000 Hz)
- Noise attenuation up to 26 dBA
- Expansion fittings not required
- Straight through design minimizes pressure drop, permitting normal valve sizing

Canadian Registration # OH6266.5RC

DIMENSIONS inches (mm) AND WEIGHTS, pounds (kg) INLET SIZE 2-1/2" TO 8"

NOMINAL PIPE SIZE			D'-INSTALLED LENGTH		APPROX. WEIGHT		Average Attenuation dBA
A	B	C	150#	300#	150#	300#	
INLET	OUTLET	SHELL	x	x	x	x	
2-1/2 (65)	4 (100)	6 (150)	47 (1010)	47 (1194)	97 (44)	109 (49)	16
2-1/2 (65)	5 (125)	6 (150)	47 1/2 (1200)	48 1/8 (1222)	99 (45)	115 (52)	16
3 (80)	4 (100)	6 (150)	47 (1009)	47 3/4 (1214)	99 (45)	103 (47)	14
3 (80)	5 (125)	6 (150)	47 1/2 (1207)	48 1/4 (1227)	101 (46)	119 (54)	14
3 (80)	6 (150)	8 (200)	58 9/16 (1488)	59 5/16 (1506)	150 (68)	181 (82)	19
4 (100)	5 (125)	6 (150)	47 3/4 (1214)	48 1/8 (1222)	105 (48)	129 (59)	12
4 (100)	6 (150)	8 (200)	54 3/4 (1392)	55 1/2 (1410)	162 (74)	178 (81)	16
4 (100)	8 (200)	10 (250)	66 1/4 (1684)	67 (1702)	256 (116)	299 (134)	21
5 (125)	6 (150)	8 (200)	55 1/4 (1405)	56 (1422)	180 (82)	167 (76)	14
5 (125)	8 (200)	10 (250)	66 3/4 (1696)	67 1/2 (1715)	289 (131)	247 (130)	19
5 (125)	10 (250)	12 (300)	89 5/16 (2268)	90 5/16 (2294)	455 (207)	428 (194)	26
6 (150)	8 (200)	10 (350)	66 3/4 (1697)	67 1/2 (1715)	295 (134)	299 (136)	17
6 (150)	10 (250)	12 (300)	83 3/4 (2129)	84 3/4 (2154)	451 (205)	490 (222)	24
8 (200)	10 (250)	12 (300)	84 1/4 (2141)	85 1/4 (2166)	468 (213)	507 (230)	21

* +1/4" for 8" Shell and under, otherwise ± 3/8".

+ Consult factory for specifics.

SEPA,
DESUPER,
NOISE

NOISE SUPPRESSOR

SPECIFICATION

Noise Suppression equipment shall be of the dissipative reactive type. Suppressor shall not induce back pressure. It shall have expanded outlet flange for attachment to downstream piping. Equipment shall provide a minimum of 10 dBA reduction in noise. Installation must be insulated.

MATERIALS OF CONSTRUCTION

Pressure Shell Welded Steel Components
Acoustic Material Stainless Steel

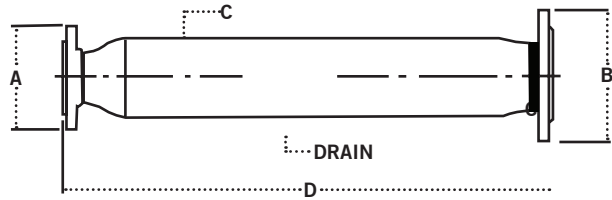

MAXIMUM OUTLET VELOCITY

feet per minute (meters per minute)

NOMINAL PIPE SIZE	NOMINAL PIPE SIZE
0 - 2 (0 - 51)	17,000 (5182)
2-1/2 - 8 (64 - 203)	11,000 (3353)
>8 (>203)	9,000 (2734)

DIMENSIONS inches (mm) AND WEIGHTS pounds (kg) INLET SIZES 3/8" to 2"

NOMINAL PIPE SIZE			D* — INSTALLED LENGTH			APPROX. WEIGHT						Average Attenuation dBa1*
A INLET	B OUTLET	C SHELL	NPT x 150 NPT x 300	NPT x 150 NPT x 300	150# x 150#	NPT x NPT	NPT x 150#	NPT x 300#	150# x 150#	300# x 150#	300# x 300#	
3/8 (10)	3/4 (19)	2 (51)	18 (457)	19 5/8 (498)		8 (203)	9 (229)	10 (254)				16
3/8 (10)	1 (25)	2 (51)	18 5/16 (465)	19 3/4 (502)		8 (203)	10 (254)	11 (279)				16
3/8 (10)	1 1/2 (38)	22 3/4 (578)	26 5/8 (676)	22 1/2 (572)		12 (305)	15 (381)	18 (457)				22
1/2 (13)	1 (25)	20 (508)	21 5/16 (541)	19 3/4 (502)	19 9/16 (497)	8 (203)	10 (254)	11 (279)	12 (305)	12 (305)	13 (330)	12
1/2 (13)	1 1/4 (32)	22 5/8 (575)	23 15/16 (608)	22 5/16 (567)	22 1/8 (562)	12 (305)	13 (330)	16 (406)	15 (381)	15 (381)	17 (427)	15
1/2 (13)	1 1/2 (38)	22 3/4 (578)	27 1/16 (687)	22 1/2 (572)	22 5/16 (567)	12 (305)	15 (381)	18 (457)	16 (406)	16 (406)	19 (483)	20
3/4 (19)	1 1/4 (32)	23 5/16 (592)	28 3/8 (721)	23 (584)	22 13/16 (579)	12 (305)	14 (356)	16 (406)	15 (381)	16 (406)	18 (457)	16
3/4 (19)	2 (51)	26 1/2 (673)	28 5/8 (727)	26 1/4 (667)	26 1/16 (662)	16 (406)	21 (533)	23 (584)	22 (559)	23 (584)	25 (635)	16
1 (25)	1 1/2 (38)	21 1/8 (537)	25 3/4 (654)	20 7/8 (530)	20 5/8 (524)	13 (330)	16 (406)	19 (483)	18 (457)	19 (483)	22 (559)	12
1 (25)	2 (51)	26 11/16 (678)	36 (914)	26 7/16 (672)	26 3/16 (665)	16 (406)	21 (533)	23 (584)	23 (584)	24 (610)	26 (660)	13
1 1/4 (32)	2 (51)	24 5/16 (618)	36 1/16 (916)	24 1/16 (611)	23 3/4 (603)	16 (406)	21 (533)	23 (584)	23 (584)	25 (635)	27 (686)	14
1 1/4 (32)	3 (76)	34 11/16 (881)		34 5/16 (872)	34 (864)		40 (1016)	47 (1194)	42 (1067)	45 (1143)	51 (1295)	14
1 1/2 (38)	3 (76)	31 13/16 (808)		31 7/16 (799)	31 3/16 (792)		39 (991)	44 (1118)	43 (1092)	46 (1168)	52 (1321)	12
2 (51)	3 (76)	31 7/8 (810)		31 1/2 (800)	31 1/4 (794)		40 (1016)	46 (1168)	45 (1143)	47 (1194)	53 (1346)	10
2 (51)	4 (102)	40 1/8 (1019)		39 3/4 (1003)	39 1/2 (1003)		66 (1676)	76 (1930)	72 (1829)	74 (1880)	84 (2134)	14

* ±1/4" for 8" Shell and under, otherwise ± 3/8".

t Consult factory for specifics.

NOISE SUPPRESSOR

SPECIFICATION

Noise Suppression equipment shall be of the dissipative reactive type. Suppressor shall not induce back pressure. It shall have expanded outlet flange for attachment to downstream piping. Equipment shall provide a minimum of 10 dBA reduction in noise. Installation must be insulated.

MATERIALS OF CONSTRUCTION

Pressure Shell Welded Steel Components
Acoustic Material Stainless Steel

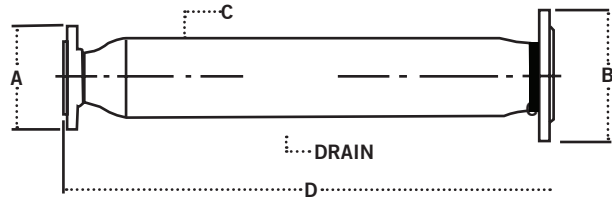

MAXIMUM OUTLET VELOCITY

feet per minute (meters per minute)

NOMINAL PIPE SIZE	NOMINAL PIPE SIZE
0 - 2 (0 - 51)	17,000 (5182)
2-1/2 - 8 (64 - 203)	11,000 (3353)
>8 (>203)	9,000 (2734)

DIMENSIONS inches (mm) AND WEIGHTS pounds (kg) INLET SIZES 2 1/2" to 8"

NOMINAL PIPE SIZE			D* — INSTALLED LENGTH			APPROX. WEIGHT			Average Attenuation dBa1*
A INLET	B OUTLET	C SHELL	NPT x 150 NPT x 300	NPT x 150 NPT x 300	300# x 300#	150# x 150#	300# x 150#	300# x 300#	
2 1/2 (64)	4 (102)	5 (127)	39 3/4 (1010)	40 (1016)	40 3/8 (1026)	73 (1854)	75 (1905)	85 (2159)	16
2 1/2 (64)	5 (125)	6 (152)	47 1/4 (1200)	47 1/2 (1207)	47 7/8 (1216)	105 (2667)	108 (2743)	123 (3124)	16
3 (76)	4 (102)	5 (127)	39 3/4 (1010)	40 1/8 (1019)	40 1/2 (1029)	76 (1930)	82 (2083)	91 (2311)	22
3 (76)	5 (127)	6 (152)	47 1/4 (1200)	47 5/8 (1210)	48 (1219)	108 (2743)	114 (2896)	129 (3277)	12
3 (76)	6 (152)	8 (203)	58 1/4 (1480)	58 5/8 (1489)	59 (1499)	174 (4420)	180 (4572)	199 (5055)	15
4 (102)	5 (127)	6 (152)	47 1/2 (1207)	47 7/8 (1216)	48 1/4 (1226)	113 (2870)	123 (3124)	138 (3505)	20
4 (102)	6 (152)	8 (203)	54 1/2 (1384)	54 7/8 (1394)	55 1/4 (1403)	175 (4445)	185 (4699)	204 (5182)	16
4 (102)	8 (203)	10 (254)	66 (1676)	66 3/8 (1686)	66 3/4 (1695)	284 (7214)	294 (7468)	321 (8153)	16
5 (127)	6 (152)	8 (203)	55 (1397)	55 3/8 (1407)	55 3/4 (1416)	180 (4572)	195 (4953)	214 (5436)	12
5 (127)	8 (203)	10 (254)	66 1/2 (1689)	66 7/8 (1699)	67 1/4 (1708)	289 (7341)	304 (7722)	331 (8407)	13
5 (127)	10 (254)	12 (305)	89 (2261)	89 3/8 (2270)	90 (2286)	455 (11557)	470 (11938)	516 (13106)	14
6 (152)	8 (203)	10 (254)	66 1/2 (1689)	66 7/8 (1699)	67 1/4 (1708)	295 (7493)	314 (7976)	341 (8661)	14
6 (152)	10 (254)	12 (305)	83 1/2 (2121)	83 7/8 (2130)	84 1/2 (2146)	451 (11455)	470 (11938)	516 (13106)	12
8 (203)	10 (254)	12 (305)	84 (2134)	84 3/8 (2143)	85 (2159)	468 (11887)	495 (12573)	541 (13741)	10

* ±1/4" for 8" Shell and under, otherwise ± 3/8".

t Consult factory for specifics.

MUFFLING ORIFICE PLATES (MOPS)

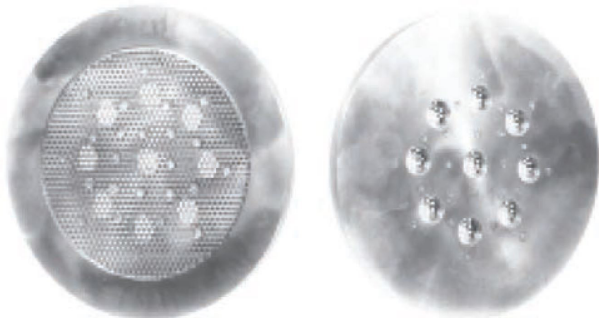

INLET **OUTLET**
MUFFLING ORIFICE

- Reduces noise by 6 dBA to 12 dBA
- Engineered for each application
- Designed to fit between ANSI flanges (DIN upon request)
- For noise reduction estimates, consult your Representative.

Canadian Registration # OH6265.5RC

MATERIALS OF CONSTRUCTION

Plate..... Steel ASTM A285-78 Gr. C.
Disc..... St. St. 302-2B

SPECIFICATION

A Muffling Orifice Plate to be constructed of materials suitable for the installation and compatible with the piping. Generally, it is to be of steel construction with stainless steel plate welded to the primary plate. The orifices are to be on the stainless steel plate. Orifice plates are to be designed for installation between two ANSI flanges in the enlarged piping downstream of the regulator or noise suppressor. Muffling Orifice Plates are to be designed to provide between 6 to 12 dBA of noise reduction on a high flow PRV.

APPLICATION DATA

- Spence Pressure Regulators or Control Valves where noise reduction is desired

SIZING INFO PAGE 163

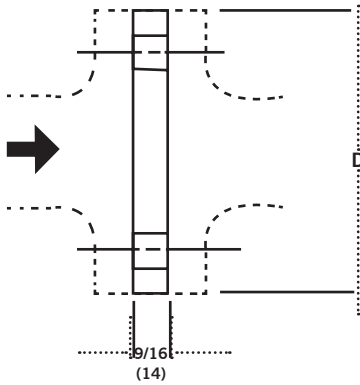

ANSI 125 AND 150 FLANGED

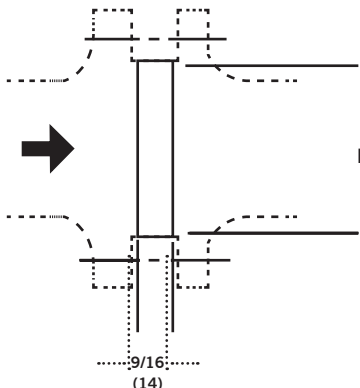

ANSI 250, 300 AND 600 FLANGED

DIMENSIONS inches(mm)

Size	Rating	Muffling Orifice Plates	
		OD	
		inch	mm
1	125/150	4.25	108
	250/300	2.81	71
	600	2.00	51
1-1/4"	125/150	4.62	117
	250/300	3.00	76
	600	2.50	64
1-1/2"	125/300	5.00	127
	250/300	3.62	92
	600	2.88	73
2	125/150	6.00	152
	250/300	4.19	106
	600	3.62	92
2-1/2"	125/150	7.00	178
	250/300	4.94	125
	600	4.12	105
3"	125/150	7.50	191
	250/300	5.69	145
	600	5.00	127
4"	125/150	9.00	229
	250/300	6.94	176
	600	6.19	157
5"	125/150	10.00	254
	250/300	8.31	211
	600	7.31	186
6"	125/150	11.00	279
	250/300	9.69	246
	600	8.50	216
8"	125/150	13.50	343
	250/300	11.94	303
	600	10.62	270
10"	125/150	16.00	406
	250/300	14.06	357
	600	12.75	324
12"	125/150	19.00	483
	250/300	16.44	418
	600	15.00	381
14"	125/150	21.00	533
	250/300	18.94	481
	600	16.25	413
16"	125/150	23.50	597
	250/300	21.06	535
	600	18.12	460
18"	125/150	25.00	635
	250/300	23.31	592
	600	23.00	584

THROTTLING ORIFICE PLATES (TOPS)

SPECIFICATION

A Throttling Orifice Plate is to be constructed of materials suitable for the installation and compatible with the piping. Generally, it is to be of steel construction with stainless steel plate pressed into a pipe nipple. The orifices are to be on the stainless steel plate. TOPs are to be designed for installation in an FNPT connection in the enlarged piping downstream of a regulator or noise suppressor. Throttling Orifice Plates are to be designed to provide between 6 to 12 dBA of noise reduction on a high flow PRV.

APPLICATIONS

- E Main Valves
- J, K Control Valves
- Anywhere steam piping noise reduction is desired

- Reduces noise by 6 dBA to 12 dBA
- Engineered for each application
- Easy to install - made from NPT pipe nipples
- For noise reduction estimates, consult your Representative.

MATERIALS OF CONSTRUCTION

Plate..... 304 SS
 Pipe Nipple.....ASTM A106/A53 Gr. B

Size	Installed Length
3/8"	1 3/16"
1/2"	15/16"
3/4"	7/8"
1"	11/16"
1 1/4"	1 1/8"
1 1/2"	1 5/8"
2"	1 5/8"

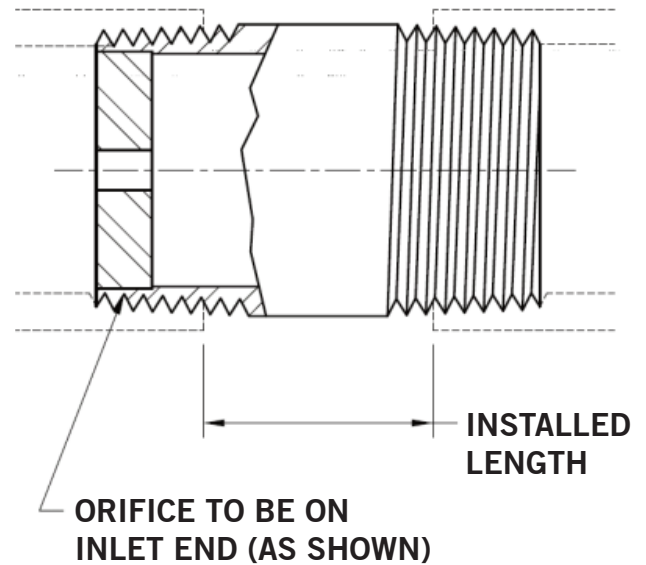

STEAM PRESSURE REDUCING STATION NOISE REDUCTION

ENVIRONMENT	TYPICAL SOUND PRESSURE LEVEL (DBA)
THRESHOLD OF PAIN	135
THRESHOLD OF DISCOMFORT	120
PNEUMATIC HAMMER	105
NOISY FACTORY	90
NOISY OFFICE	75
NORMAL CONVERSATION	60
PRIVATE OFFICE	45
BROADCAST STUDIO	30
THRESHOLD OF AVG. HEARING	15
THRESHOLD OF ACUTE HEARING	0

INTRODUCTION TO NOISE REDUCTION

WHY IS NOISE IMPORTANT?

Excessive noise is stressful to the human body and constitutes a serious health hazard. The Walsh-Healy Public Contracts Act and the Occupational Safety and Health Act have prompted system designers to pay careful attention to the noise generated by pressure reducing stations.

OSHA has established limits on the length of time any employee may be exposed to various sound levels. These limits are shown in Figure 1 below. For a typical eight hour working day, the limit is 90 dBA. OSHA does not provide sound level limits for periods longer than eight hours. Figure 1 extrapolates the OSHA limits to a full 24 hour day.

When daily exposure is composed of two or more at differing sound levels, their combined effect must be considered. In such cases, the sum of the ratios of actual to permissible exposure times must not exceed unity. that is:

$$\frac{t_1}{T_1} + \frac{t_2}{T_2} = \dots = \frac{t_n}{T_n} \leq 1$$

Where:

T = permissible time at specified noise level
 t = actual time at specified noise level
 1, 2, ..., n = differing noise levels

FIGURE 1: OSHA MANDATED NOISE EXPOSURE LIMITS*

SOUND PRESSURE LEVEL (DBA)	115	110	105	100	95	90	85	82
PERMISSIBLE EXPOSURE (HOURS PER DAY)	1/4	1/2	1	2	4	8	12	24

* Values for 12 and 24 hour per day exposure are extrapolated.

NOTE: Ear protection must be worn above 90 dBA.

WHAT IS dBA?

Sound results from pressure fluctuations in the air. The sound pressure level which the most sensitive listener can detect is about 20µN/m². This level is normally taken as the reference point for the measurement of sound pressure levels.

Sound pressure level cover an enormous range of values. In order to compress this range, sound levels are usually expressed in decibels. A decibel (dB) is simply the logarithm of the ratio of two quantities. In this case, the two quantities

are the sound pressure level being measured and the reference level. The reference level is, by definition, 0 dB.

The human ear does not respond equally to all frequencies. It tends to be insensitive to very low and very high frequencies. Standard sound level meters are equipped with a scale which approximates the human ear's response. Sounds measured on this scale are expressed as A-weighted decibels (dBA). The dBA is commonly used in engineering work.

IMPORTANT CHARACTERISTICS OF DECIBELS

ADDING SOUND LEVELS

Since decibels express a logarithmic ratio, they cannot simply be added or subtracted. Figure 2 below provides a means of adding decibels without lengthy calculations.

To add two sound levels:

1. Determine difference between sound level
2. Find correction from Figure 2.
3. Add the correction to the **higher** sound level

DECIBEL DIFFERENCE	0	1	2	3	4	5	6	7	8	9	10
DECIBEL CORRECTION	3.0	2.6	2.1	1.8	1.5	1.2	1.0	0.8	0.6	0.5	0.4

FIGURE 2

SOUND LEVEL REDUCTIONS

Similarly, a 10% reduction in the decibel level does not represent a 10% reduction in absolute sound pressure level. For example, a reduction from 60 dB to 54 dB (a 10% dB reduction) produces a 50% reduction in the

absolute sound pressure level.

A 6 dB reduction always cuts the absolute sound pressure in half. The relationship between decibel and absolute sound pressure level reductions is summarized in Figure 3.

RELATIVE REDUCTION (dB)	1	2	3	4	5	6	10	20	40
ABSOLUTE REDUCTION (%)	11	21	29	37	44	50	68	90	99

FIGURE 3

SOUND LEVELS DECREASE WITH DISTANCE

Sound ratings for reducing valves are conventionally established at a point three feet downstream from the valve's outlet and three feet from the outlet pipe's surface. At further distances from the pipe surface, the radiated sound drops off in intensity. Some typical values are shown below in Figure 4.

The values shown in Figure 4 assume that the valve is acoustically isolated from the surrounding structure. Sound can be transmitted throughout the structure with little attenuation if the piping system is not properly isolated or if surroundings are acoustically "hard". The piping system itself can also act as a conduit for sound.

DISTANCE FROM PIPE	3 Ft.	6 Ft.	12 Ft.	25 Ft.	50 Ft.
SOUND REDUCTION	0 dBA	3 dBA	6 dBA	9 dBA	12 dBA

FIGURE 4

NOISE REDUCTION DESIGN GUIDELINES

1. Size the regulator to provide a maximum inlet velocity of about 10,000 FPM.
2. Determine the regulator outlet velocity. If it would exceed 30,000 FPM, use a Spence Muffling Orifice or a second stage regulator.
3. Expand regulator outlet piping to limit discharge line velocity to about 10,000 FPM.
4. Avoid abrupt changes in pipe size. Limit pipe diameter changes to two pipe sizes per stage of expansion. Do not use eccentric reducers.
5. Directional changes in downstream piping should be made only after the line size has been increased. Use long radius fittings; avoid bullhead tee connections.
6. Provide as much straight run of pipe on both sides of the regulator as possible:
 - a. 10 pipe diameters minimum to the inlet.
 - b. 20 pipe diameters minimum of expanded line size from the outlet.
7. Size all piping components, including strainer and stop valves for a maximum flow velocity of about 10,000 FPM (Exception: An outlet stop valve mounted at the regulator outlet should be equal in size to the regulator.) In areas where low sound levels are specified, reduce this limit by 25% to 50%.
8. To limit noise transmission through the building's structure, keep the regulator and piping at least 3 feet away from solid surfaces. Use sound isolating piping supports.
9. Apply high density insulation to regulator body, piping and system components. Insulation reduces heat loss significantly and can provide moderate (3-6 dB) local noise attenuation. For greater noise reduction, use removable Spence Insulcap Jacket with lead lining on regulator body.
10. Use a Spence Noise Suppressor to reduce the propagation of noise via the downstream piping

SELECTING NOISE REDUCING DEVICES

SOURCE TREATMENT

A Spence Muffling Orifice will reduce high flow pressure regulator noise by 6 to 10 dBA. Installed in the expanded

downstream piping, the Muffling Orifice reduces the generation of noise at its source

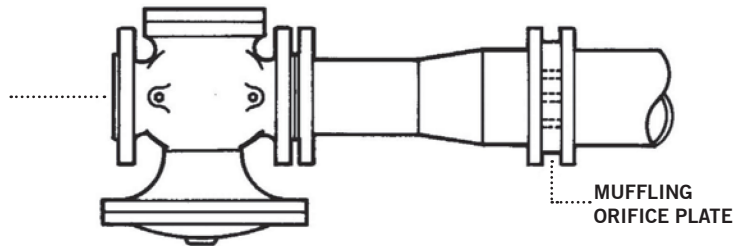

FIGURE 5A: SINGLE STAGE INSTALLATION WITH MUFFLING ORIFICE

PATH TREATMENT

A Spence Noise Suppressor will reduce pipeline carried noise by 10 to 20 dBA. Installed at the regulator outlet,

the Suppressor absorbs noise generated by the pressure regulator and limits its propagation through the piping system.

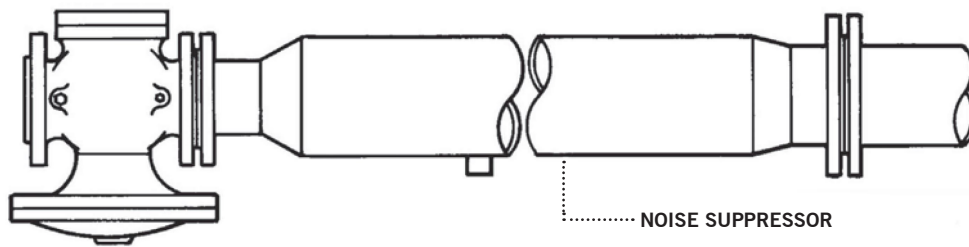

FIGURE 5B: SINGLE STAGE INSTALLATION WITH NOISE SUPPRESSOR

SOURCE AND PATH TREATMENT

For maximum reduction of pipeline transmitted noise, the combined installation of a Spence Muffling Orifice and Spence Noise Suppressor will reduce the sound pressure

level by 15 to 30 dBA. Installation of a Spence Insulcap Jacket with lead lining on the regulator body will further reduce sound pressure levels.

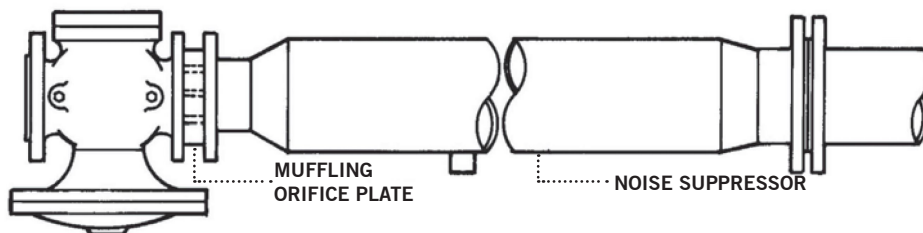

FIGURE 5C: SINGLE STAGE INSTALLATION WITH MUFFLING ORIFICE AND NOISE SUPPRESSOR

SIZING NOISE REDUCTION COMPONENTS

SELECTION OF SIZE AND TYPE OF COMPONENTS

REGULATOR SIZE

1. Enter Saturated Steam Flow Table (opposite) at the specified **initial pressure**. Read across the first tabulated value which includes the specified steam flow. The regulator size at the head of this column is the minimum required to limit inlet velocity to 10,000 FPM.
2. Move up this column to the specified **reduced pressure** (chosen outlet pressure, if Muffling Orifice is used) and note the tabulated flow value. If the specified flow is more than three times the tabulated flow, the regulator's exit velocity will exceed 30,000 FPM. (Use a Spence Muffling orifice or a second stage reduction.)

DELIVERY PIPE SIZE

Enter Saturated Steam Flow Table (opposite) at the specified reduced pressure. Read across to the first tabulated value which includes the specified steam flow. The pipe size at the head of this column is the minimum expanded pipe size to limit velocity to 10,000 FPM.

MUFFLING ORIFICE SIZE

If a Noise Suppressor is installed, the Muffling Orifice size is the same as the regulator size. Otherwise, it is the same as the delivery pipe size.

NOISE SUPPRESSOR SIZE

The inlet size of the Noise Suppressor is the same as the regulator size. The outlet size is the same as the delivery pipe size.

ANSWER: 2-1/2" SPENCE REGULATOR WITH MUFFLING ORIFICE, NOISE SUPPRESSOR AND 5" DELIVERY PIPE.

NOTE: Regulators should always be protected by properly designed Strainers.

EXAMPLE

SPECIFIED CONDITIONS

Saturated Steam Flow	= 5,000 lb/hr
Initial Pressure	= 100 PSIG
Reduced Pressure	= 15 PSIG

REGULATOR SIZE

Entering Saturated Steam Flow Table (opposite) at 100 psig, the first tabulated value which includes 5,000 lb/hr is 5141 lb/hr. The head of this column indicates a 2^{1/2}" regulator is required to limit inlet velocity to 10,000 FPM.

Moving up this column to 15 psig, the tabulated flow is 1452 lb/hr. Specified flow is 3.47 times the tabulated flow. The exit velocity for a 2^{1/2}" regulator will be 34,700 FPM. The use of a Muffling Orifice is indicated.

DELIVERY PIPE SIZE

Entering Saturated Steam Flow Table (opposite) at 15 psig, the first tabulated value which includes 5000 lb/hr is 6030 lb/hr. The delivery pipe size at the head of this column is 5". For this pipe size, flow velocity will be 8,290 FPM.

CALCULATING VELOCITY

VELOCITY FORMULA

The Saturated Steam Flow Tables (opposite) provide a convenient means of calculating flow velocity. The flows tabulated are based on 10,000 feet per minute (FPM) velocity. The velocities at other steam flows can be obtained by simple proportioning:

$$\text{Actual Velocity} = \frac{\text{Actual Flow}}{\text{Tabulated Flow}} \times 10,000 \text{ FPM}$$

Example

Pipe size	=	5"
Pressure	=	15 psig
Tabulated flow	=	6,030 lb/hr
Actual flow	=	5,000 lb/hr

$$\text{Actual Velocity} = \frac{5,000}{6,030} \times 10,000 \text{ FPM} = 8,290 \text{ FPM}$$

SATURATED STEAM FLOW TABLE

(LB/HR) AT 10,000 FPM

BASED ON SCHEDULE 40 PIPE

SIZES 3/8" THROUGH 4"

PRESS. (PSIG)	TEMP (°F)	REGULATOR or PIPE SIZE (inches)									
		3/8	1/2	3/4	1	1 1/4	1 1/2	2	2-1/2	3	4
-10	160	10	15	27	43	75	102	168	239	370	637
-5	192	21	33	58	94	162	221	364	519	802	1381
0	212	30	47	83	134	233	317	522	744	1149	1979
5	228	40	63	111	179	310	422	696	993	1533	2641
10	240	49	78	136	221	382	520	858	1224	1890	3254
15	250	58	92	162	262	454	617	1018	1452	2242	3860
20	259	67	106	187	303	524	713	1176	1678	2591	4461
25	267	76	121	212	343	594	809	1333	1902	2936	5057
30	274	85	135	237	383	664	903	1489	2124	3280	5649
40	287	102	163	286	463	801	1090	1797	2564	3959	6818
50	298	120	190	334	542	937	1276	2103	3000	4632	7976
60	308	137	218	382	620	1073	1460	2406	3434	5302	9130
70	316	154	245	430	697	1205	1641	2704	3859	5958	10260
80	324	171	272	478	774	1340	1824	3007	4290	6624	11407
90	331	188	299	525	851	1473	2005	3305	4716	7282	12540
100	338	205	326	573	928	1606	2186	3604	5141	7939	13671
125	353	247	394	691	1119	1937	2637	4346	6201	9575	16488
150	366	289	460	808	1309	2266	3085	5084	7254	11201	19288
175	378	331	528	926	1500	2597	3534	5826	8312	12834	22101
200	388	373	594	1043	1691	2926	3982	6564	9366	14461	24903
250	406	457	728	1277	2070	3582	4875	8035	11465	17703	30484
300	422	545	867	1522	2466	4269	5810	9576	13664	21098	36331
400	448	710	1130	1984	3215	5564	7574	12484	17812	27502	47360
500	470	884	1407	2469	4001	6925	9425	15535	22166	34225	58936
600	489	1061	1688	2963	4801	8310	11310	18642	26599	41070	70724

SIZES 5" THROUGH 24"

PRESS. (PSIG)	TEMP (°F)	REGULATOR or PIPE SIZE (inches)									
		5	6	8	10	12	14	16	18	20	24
-10	160	1001	1445	2502	3944	5599	6767	8839	11189	13903	20108
-5	192	2170	3133	5425	8552	12139	14671	19165	24258	30143	43597
0	212	3110	4492	7778	12260	17403	21033	27475	34778	43215	62503
5	228	4150	5993	10377	16357	23218	28061	36656	46398	57655	83388
10	240	5114	7385	12787	20156	28611	34578	45170	57175	71045	102755
15	250	6067	8761	15171	23913	33943	41023	53589	67831	84287	121908
20	259	7011	10124	17531	27633	39225	47406	61927	78386	97402	140876
25	267	7946	11475	19871	31321	44460	53732	70192	88847	110401	159677
30	274	8877	12820	22199	34990	49668	60027	78414	99255	123334	178382
40	287	10714	15473	26793	42231	59946	72449	94641	119795	148857	215297
50	298	12535	18102	31345	49407	70133	84760	110723	140151	174151	251881
60	308	14347	20719	35877	56551	80272	97014	126732	160414	199330	288298
70	316	16123	23284	40318	63551	90209	109024	142420	180272	224005	323986
80	324	17926	25887	44827	70658	100297	121215	158346	200431	249055	360217
90	331	19706	28458	49278	77674	110256	133251	174069	220332	273784	395983
100	338	21484	31025	53723	84680	120202	145271	189771	240207	298481	431704
125	353	25912	37419	64795	102132	144974	175210	228881	289712	359996	520675
150	366	30312	43773	75798	119476	169593	204964	267749	338910	421130	609095
175	378	34732	50157	86852	136900	194326	234855	306796	388335	482544	697921
200	388	39135	56515	97862	154253	218959	264625	345686	437560	543712	786390
250	406	47907	69182	119796	188827	268036	323938	423167	535634	665579	962649
300	422	57094	82449	142771	225041	319440	386063	504322	638359	793224	1147267
400	448	74426	107479	186112	293357	416413	503261	657420	832146	1034024	1495545
500	470	92620	133751	231607	365066	518202	626280	818123	1035560	1286785	1861122
600	489	111143	160501	277928	438079	621843	751536	981748	1242672	1544142	2233347

SEPA,
DESUPER,
, NOISE

NOISE REDUCTION COMPONENT FLOW COEFFICIENTS

1. Enter Cv Table below at the component's (regulator or orifice) **inlet pressure**. Read the tabulated value for **W/C_v** at the component's **outlet pressure**.

2. Divide the specified steam flow by the tabulated W/C_v to obtain the regulator (OVA) or orifice (Cvo) required flow coefficient.

Note that the lowest outlet pressure listed for each inlet pressure corresponds to a critical pressure drop. An outlet pressure lower than this will not provide any further increase in flow.

Refer to Rated Steam Capacity Tables earlier in this Section for rated capacities and minimum pressure drops for Spence Regulators. The definition of component **inlet** and **outlet pressures** is below.

FLOW FOR C_v = 1 TABLE
(W/C_v - LB/HR)

INLET PRESSURE (PSIG)	OUTLET PRESSURE (PSIG)	W/C _v	INLET PRESSURE (PSIG)	OUTLET PRESSURE (PSIG)	W/C _v	INLET PRESSURE (PSIG)	OUTLET PRESSURE (PSIG)	W/C _v	INLET PRESSURE (PSIG)	OUTLET PRESSURE (PSIG)	W/C _v
600	550	510	300	275	258	100	90	98.4	40	35	48.0
	500	706		250	357		80	136		33	56.2
	450	845		225	428		70	162		30	66.2
	400	953		200	483		60	183		25	79.0
	350	1040		175	527		55	191		20	88.8
	342	1050		168	538		52	196		17	93.6
550	500	488	250	225	236	90	80	93.8	30	25	43.1
	450	674		200	325		75	113		24	47.0
	400	805		175	388		70	129		22	53.6
	350	905		150	435		60	154		20	59.2
	325	947		145	433		50	173		15	70.2
	313	966		139	453		46	179		11	76.5
500	450	465	200	190	136	80	70	88.9	25	20	40.5
	400	640		175	211		60	122		19	44.1
	350	763		150	289		55	135		18	47.3
	325	812		125	342		50	145		15	55.3
	300	855		115	359		45	154		10	65.3
	284	881		110	367		40	162		8.3	67.9
450	400	440	175	165	128	70	60	83.8	20	15	37.7
	350	605		150	198		55	101		14	41.0
	325	666		125	270		50	115		13	43.9
	300	718		115	291		45	126		12	46.5
	275	763		100	317		40	136		10	51.2
	255	795		95	325		34	145		5.4	59.4
400	350	415	150	140	119	60	50	78.4	15	10	34.6
	325	500		125	183		45	94.3		9	37.6
	300	567		100	248		40	107		8	40.2
	275	623		90	267		35	117		7	42.6
	250	670		85	275		30	126		5	46.7
	226	709		81	282		29	128		2.5	50.8
350	300	387	125	115	109	50	45	52.4	10	5	31.3
	275	465		100	168		40	72.6		4	33.9
	250	527		90	194		35	87.0		3	36.2
	225	577		80	216		30	98.2		2	38.2
	200	619		75	225		25	107		0	41.7
	197	624		66	239		23	111		-0.4	42.3

DEFINITION OF COMPONENT PRESSURE

COMPONENT	REGULATOR ONLY		REGULATOR PLUS ORIFICE	
	INLET PRESSURE	OUTLET PRESSURE	INLET PRESSURE	OUTLET PRESSURE
REGULATOR	Initial Pressure	Reduced Pressure	Initial Pressure	+
ORIFICE	N/A	N/A	+	Reduced Pressure

+ Chosen regulator outlet/orifice inlet pressure. A rule of thumb is to chose this pressure so that regulator flow is barely subcritical.

SOUND PRESSURE LEVEL (SPL) CALCULATIONS

REGULATOR SOUND PRESSURE LEVEL

REGULATOR SIZE

1. Enter Regulator Sound Pressure Level Chart L_1 of SPLR at top of following page at the specified **initial pressure**. Move vertically to the specified **reduced pressure** (chosen outlet pressure, if Muffling Orifice is used). Read L_1 to the left of this intersection.
2. Enter Regulator Sound Pressure Level Chart L_2 of SPLR at bottom of following page at the required **regulator flow coefficient** (CV_R). Move vertically to the delivery pipe size. Read L_2 to the left of this intersection.
3. Regulator sound pressure level is:
SPLR = $L_1 + L_2$
 NOTE: If SPLR exceeds specified limits, use a Muffling Orifice to reduce the regulator's pressure drop.

MUFFLING ORIFICE SOUND PRESSURE LEVEL

REGULATOR SIZE

1. Enter Muffling Orifice Sound Pressure Level Chart L_3 of SPLO at top of following page at the chosen **orifice inlet** (regulator outlet) pressure. Move vertically to the specified **reduced pressure**. Read L_3 to the left of this intersection.
2. Enter Muffling Orifice Sound Pressure Level Chart L_4 of SPLO at bottom of following page at the required **orifice flow coefficient** (CV_0). Move vertically to the orifice plate size. Read L_4 to the left of this intersection.
3. Regulator sound pressure level is:
SPLO = $L_3 + L_4$

COMBINED SOUND PRESSURE LEVEL

Combine **SPLO** and **SPLR** as follows:

1. Determine difference between **SPLO** and **SPLR**.
2. Find correction from dB Correction Table at right.
3. Add the correction to the **higher** SPL.

EXAMPLE

SPECIFIED CONDITIONS

Saturated Steam Flow	= 5,000 lb/hr
Initial Pressure	= 100 PSIG
Reduced Pressure	= 15 PSIG

From the component sizing example on preceding pages, a 2-1/2" regulator with a 5" Muffling Orifice is required. Choose an orifice inlet (regulator outlet) pressure of 55 PSIG (critical pressure is 52 PSIG).

Entering Flow for $Cv=1$ Table on facing page at 100 PSIG, $W/Cv = 191$ at 55 PSIG outlet pressure. Thus $CVR = (5,000 \div 191) = 26.2$.

Flow for $Cv=1$ Table does not provide a listing for 55 PSIG inlet pressure. Using the critical pressures at both 60 PSIG and 50 PSIG, we estimate that $W/Cv = (128 + 111) - 2 = 120$; thus $CV0 = (5,000 \div 120) = 41.7$.

Entering L_1 of SPLR Chart on following page at 100 PSIG, $L_1 = 41$ at 55 PSIG outlet pressure. Entering L_2 of SPLR Chart at $CVR = 26.2$, $L_2 = 37$ at 5" pipe size. Thus $SPLR = L_1 + L_2 = 78$ dBA.

Entering L_3 of SPLO Chart on following page at 55 PSIG, $L_3 = 52$ at 15 PSIG reduced pressure. Entering L_4 of SPLO Chart at $CV0 = 41.7$, $L_4 = 16$ at 5" plate size. Thus $SPLO = L_3 + L_4 = 68$ dBA.

$SPLR - SPLO = 10$ dBA. From the dB Correction Table below, the decibel correction is 0.4 dB. Thus the combined $SPL = SPLR + 0.4 = 78.4$ dBA.

REGULATOR SOUND PRESSURE LEVEL CHARTS

L1 OF SPLR CHART

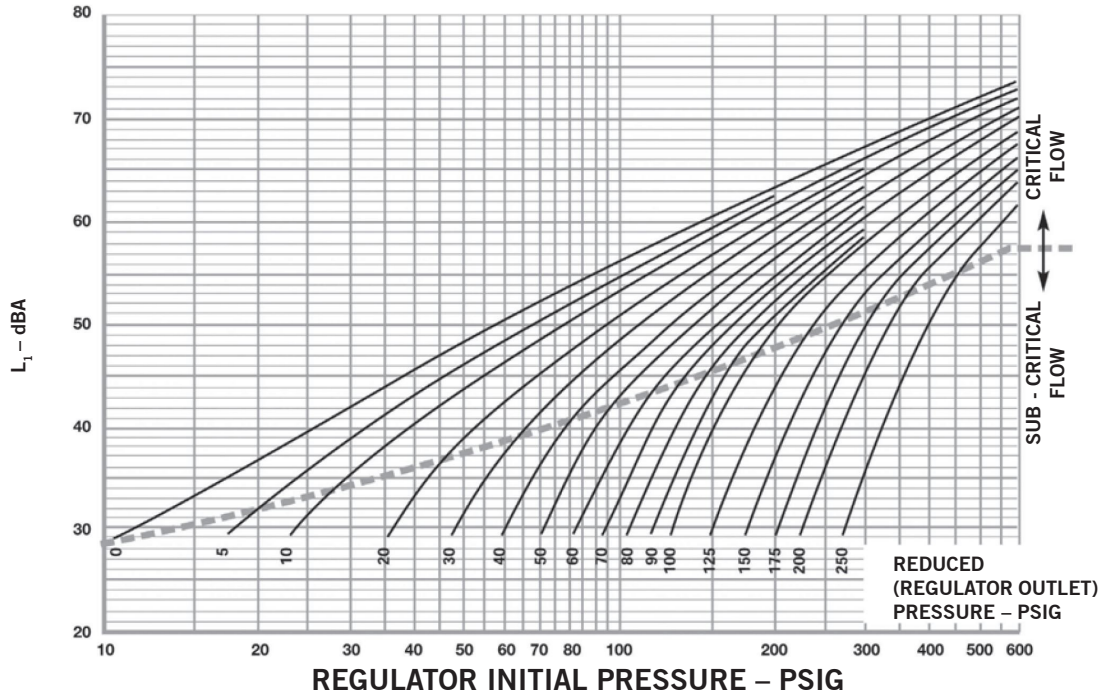

L2 OF SPLR CHART

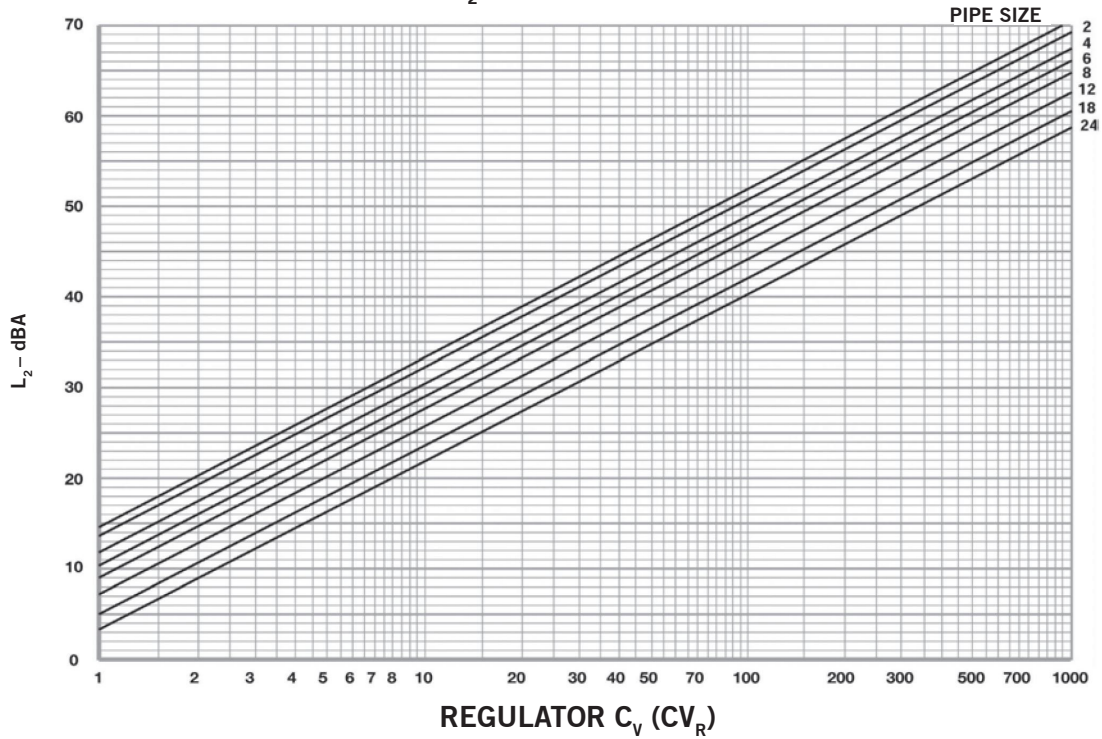

MUFLING ORIFICE SOUND PRESSURE LEVEL CHARTS

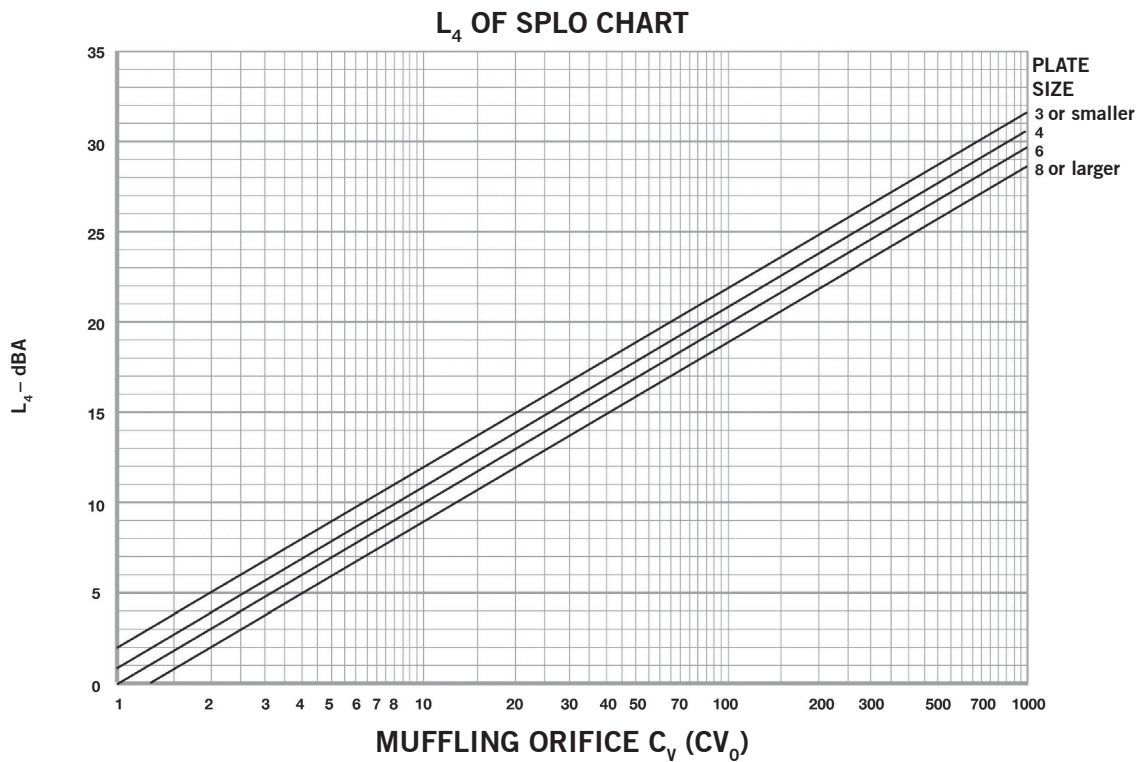
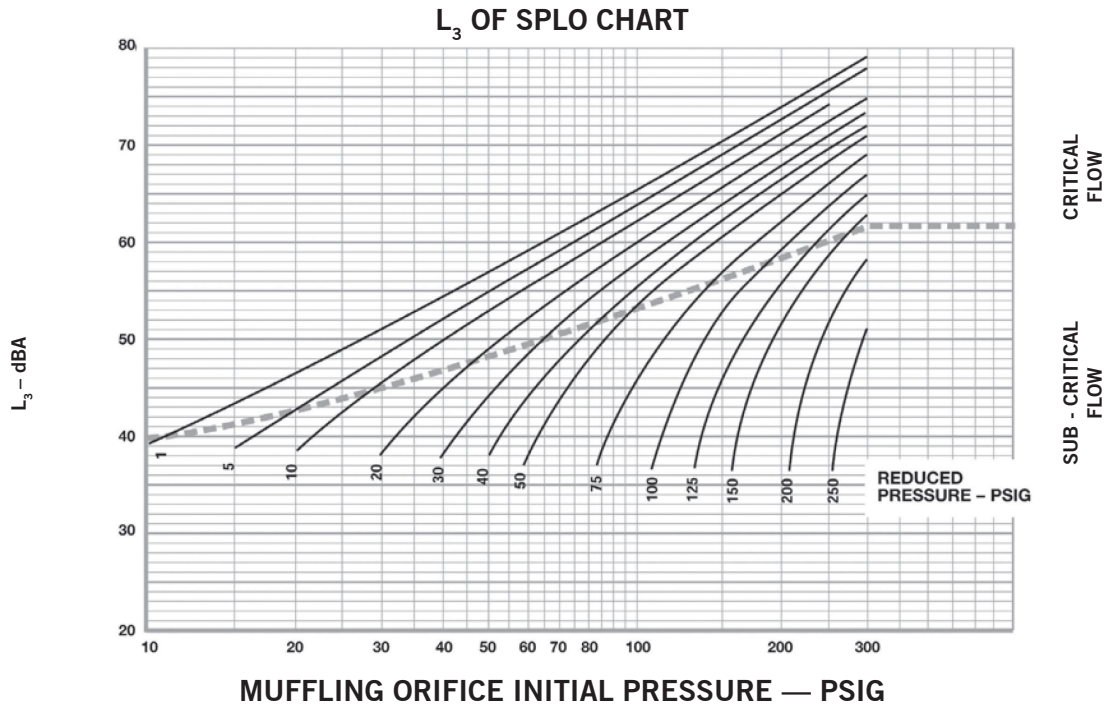

SEPA...
DESUPER...
, NOISE

SECTION IV

APPLICATION GUIDE

TYPE ED SINGLE STAGE PRESSURE REDUCING VALVE

APPLICATION:

To reduce a steady or varying Inlet pressure to a constant adjustable delivery pressure.

OPERATION:

Valve is operated by incoming pressure. As delivery pressure nears spring setting on pilot, valve starts to modulate and maintain set pressure.

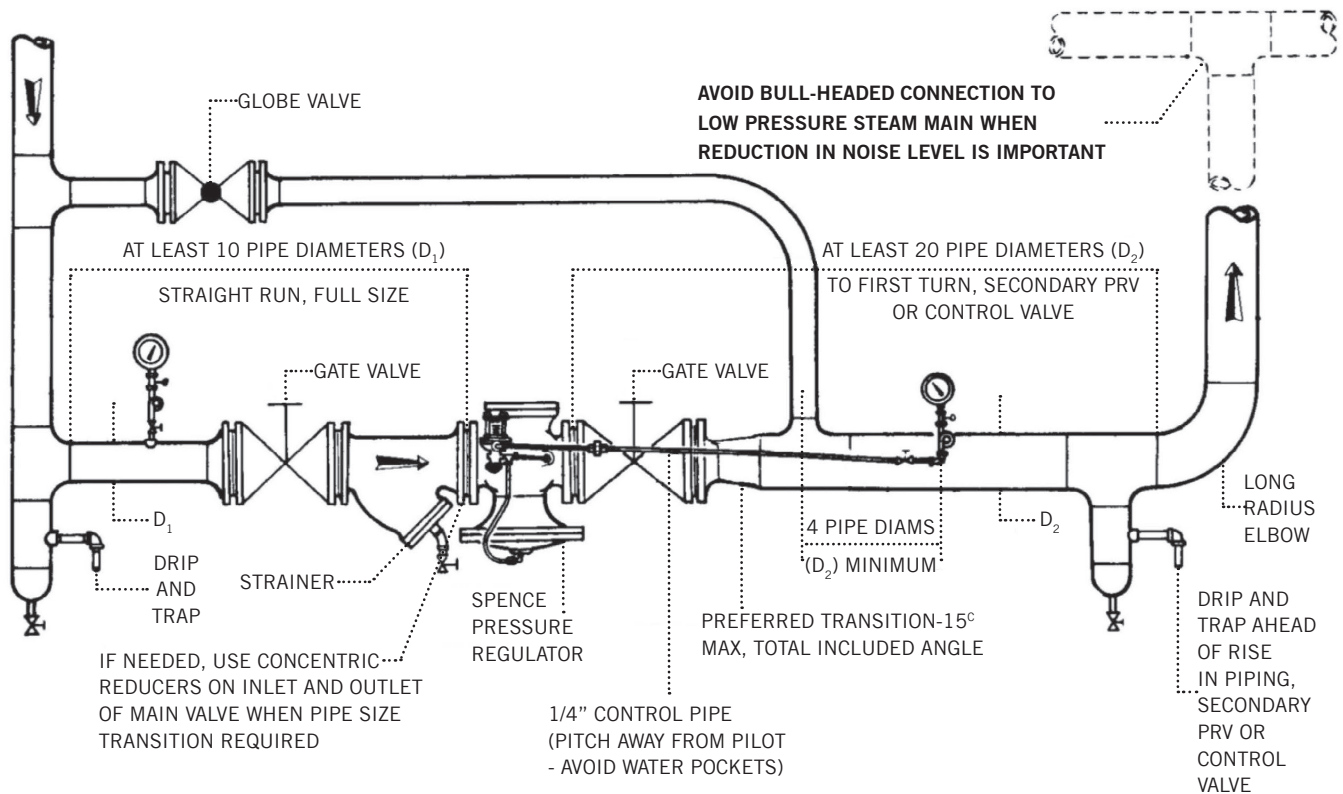

RECOMMENDED INSTALLATION OF REGULATOR WITH STRAINER

ADVANTAGES:

- Accurate, sensitive control.
- Packless construction.
- High capacity.
- Inexpensive.

TYPE ED PARALLEL (ADDITIVE) PRESSURE REDUCING STATION

APPLICATION:

Used on widely varying flow conditions

OPERATION:

Load is typically split 1/3 - 2/3. Small valve is sized for 1/3 of load and is lead valve set for desired delivery pressure. Large valve is lag valve set 2 - 3 psig lower than delivery pressure of small valve. On low flow demand, small valve only will be flowing; as flow increases and small valve cannot handle flow, the delivery pressure drops and large valve opens

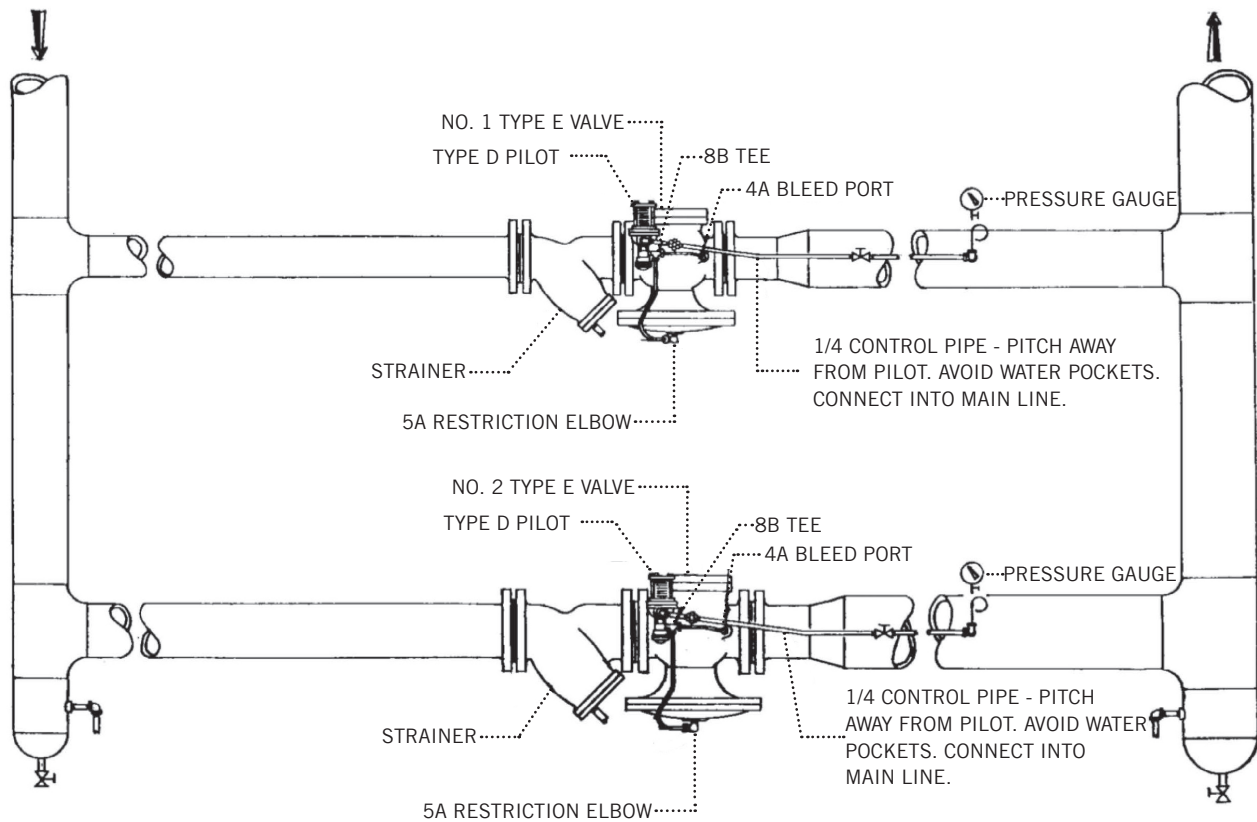

NOTE: PILOT FOR PRV NO.1 TO BE SET HIGHER THAN PILOT FOR PRV NO. 2

ADVANTAGES:

Better rangeability.
Accurate control.

TYPE ED TWO-STAGE PRESSURE REDUCING STATION

APPLICATION:

Used when reducing from high inlet pressure to low delivery pressure.

OPERATION:

Same as single stage reduction. When delivery pressure approaches spring setting on pilot, main valve throttles to maintain setting.

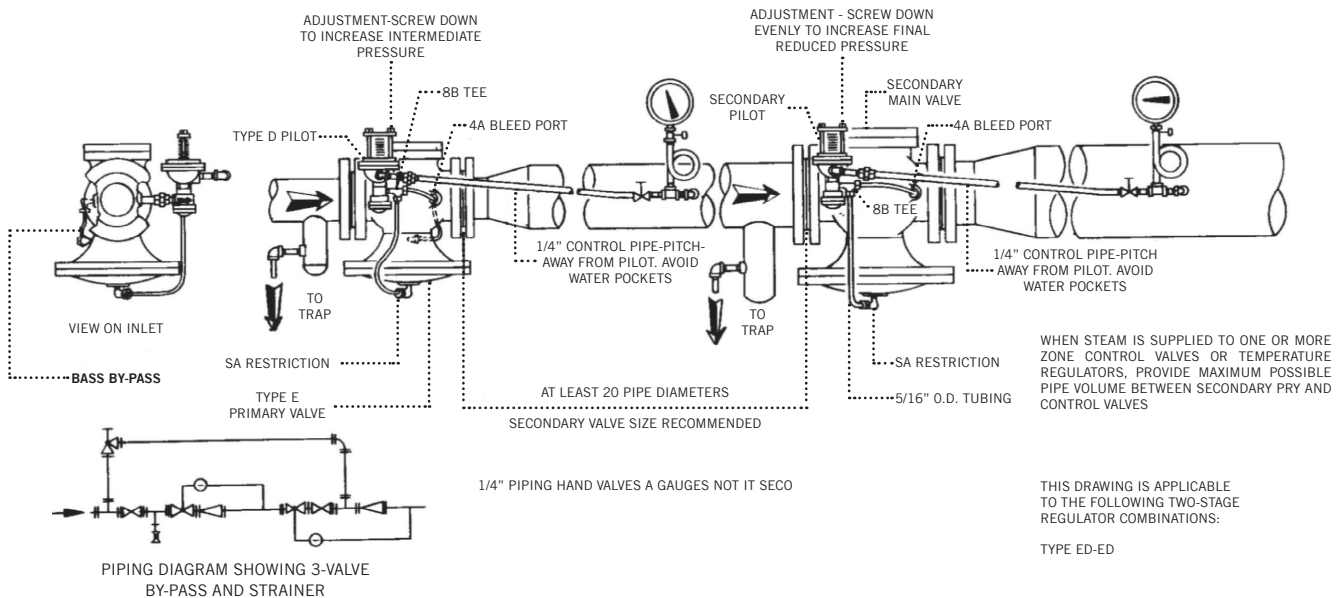

ADVANTAGES:

- Less velocity noise.
- Less maintenance costs.
- Safety is increased.

TYPE ED TURBINE EXHAUST MAKE-UP VALVE

APPLICATION:

To provide additional (make-up) steam to turbine exhaust main.

OPERATION:

When turbine load decreases and turbine exhaust is insufficient for steam load, very slight drop in exhaust pressure causes pressure regulator to feed correct amount of steam to meet demand.

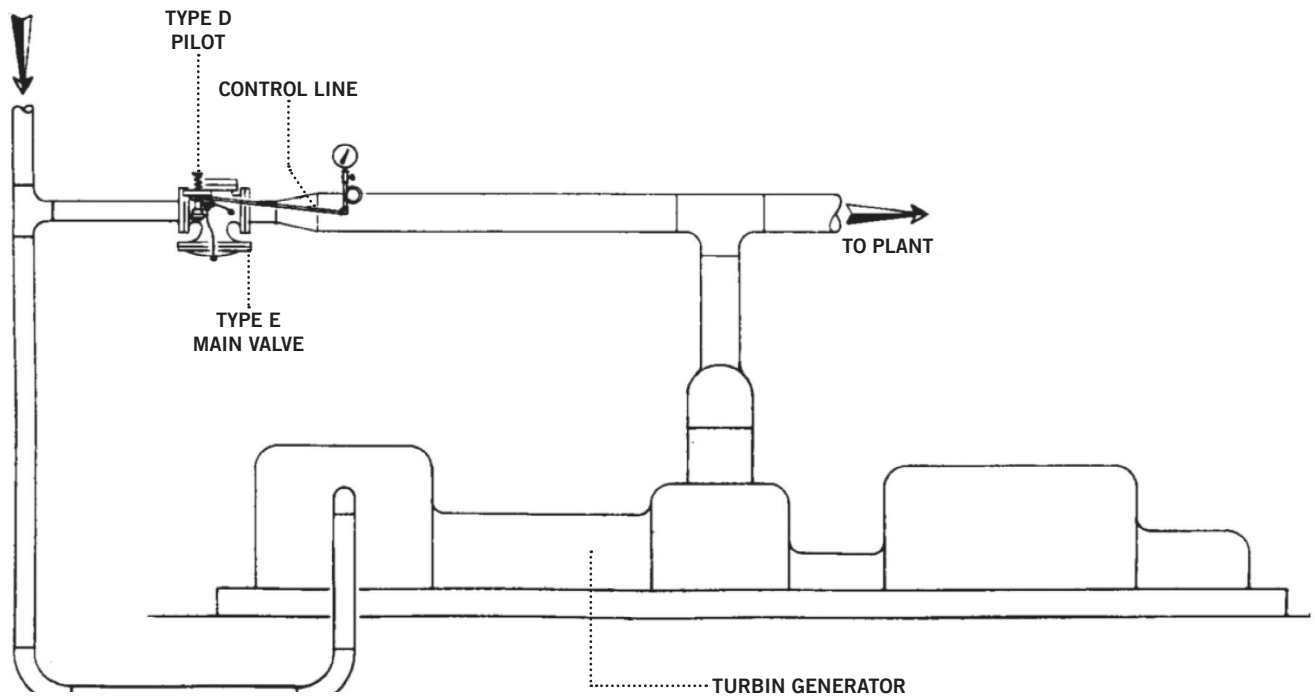

ADVANTAGES:

Pilot operated accuracy avoids undue pressure drop before makeup starts.

Constant accurate supply to user.

Ease of operation - "set and forget".

TYPE ED REMOTE SHUT OFF

APPLICATION:

Provides easy shut-down on a process where frequent shut-down is required.

OPERATION:

Same as standard ED, except, closing 1/4" gate valve denies steam to the pilot and shuts main valve.

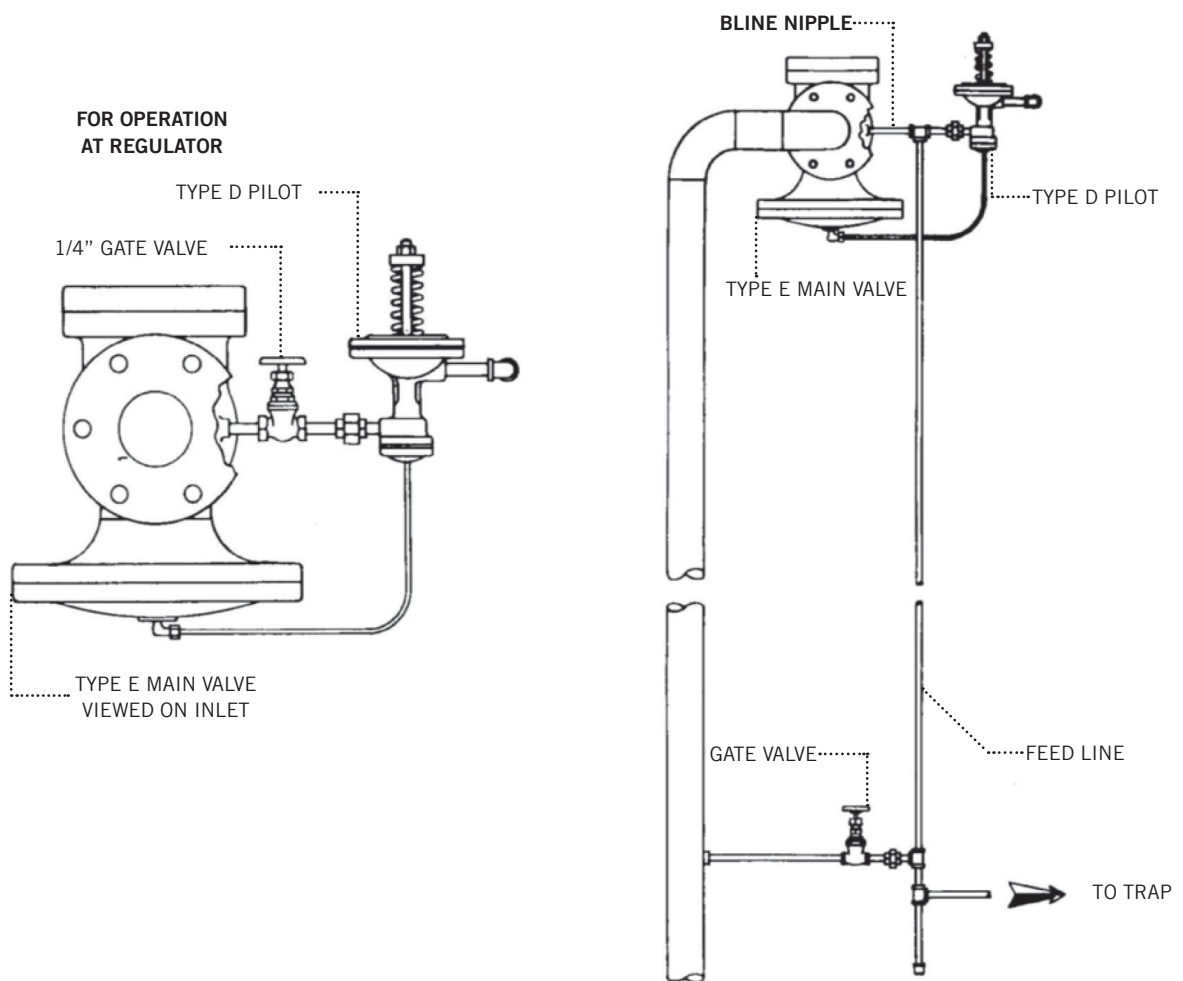

ADVANTAGES:

Easier and much faster than opening and closing the larger gate valve in main.

Reduces maintenance on the gate valve in the main line.

Self contained.

TYPE ED REMOTE MOUNTED PILOT

APPLICATION:

Provides remote location of pilot to area where pressure can be easily adjusted.

OPERATION:

Standard ED operation.

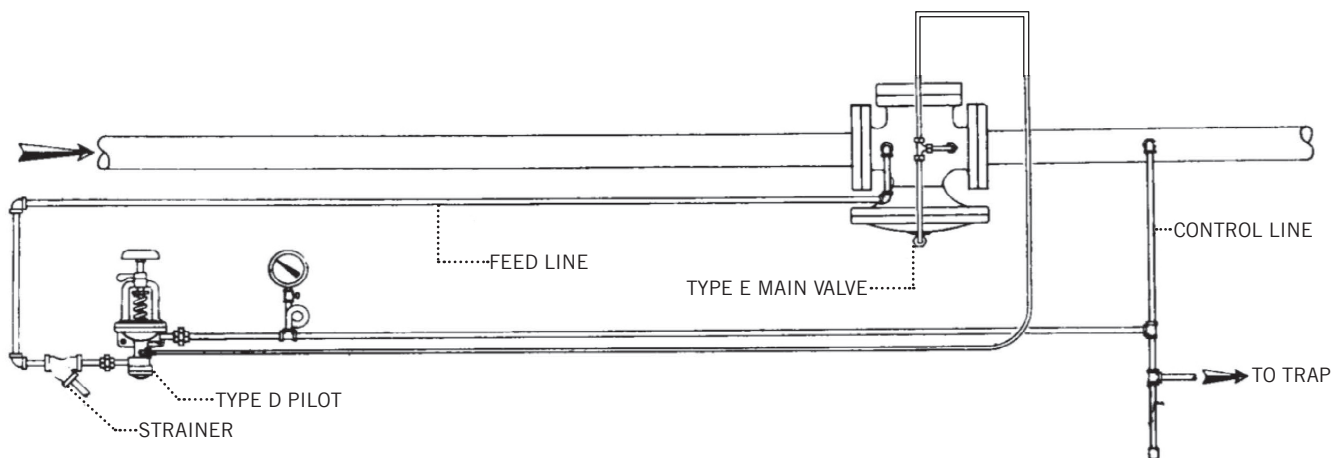

ADVANTAGES:

- Least expensive of remote-adjusting arrangements (less than special extra equipment or re-routing main piping).
- Maintenance personnel, who understand operation of standard mounted regulator, have nothing new to learn.
- Can be applied to existing regulators by merely extending connections.
- Can be furnished with panel board and gages.

TYPE EP125 TRIP VALVE

APPLICATION:

In some district heating and steam distribution systems, the use of relief valves and vent piping may not be feasible, because of building height. Where such a condition exists, and the system steam pressure does not exceed 400 psi, ANSI B31.1-1977, Paragraph 102.2.5 permits the use of a pressure reducing valve and a trip stop valve in series to provide over-pressure protection.

The P125 trip pilot is a self-contained device intended to be used in conjunction with a normally-closed Spence main valve, as cited in previous paragraph.

OPERATION:

During normal operation, the P125 pilot holds its main valve in the open position. Reduced pressure is under control of primary P.R.V

If reduced pressure rises to the set point of P125 (generally 5 psig over controlled pressure) it will shut and lock closed. This action closes its main valve and shuts system off.

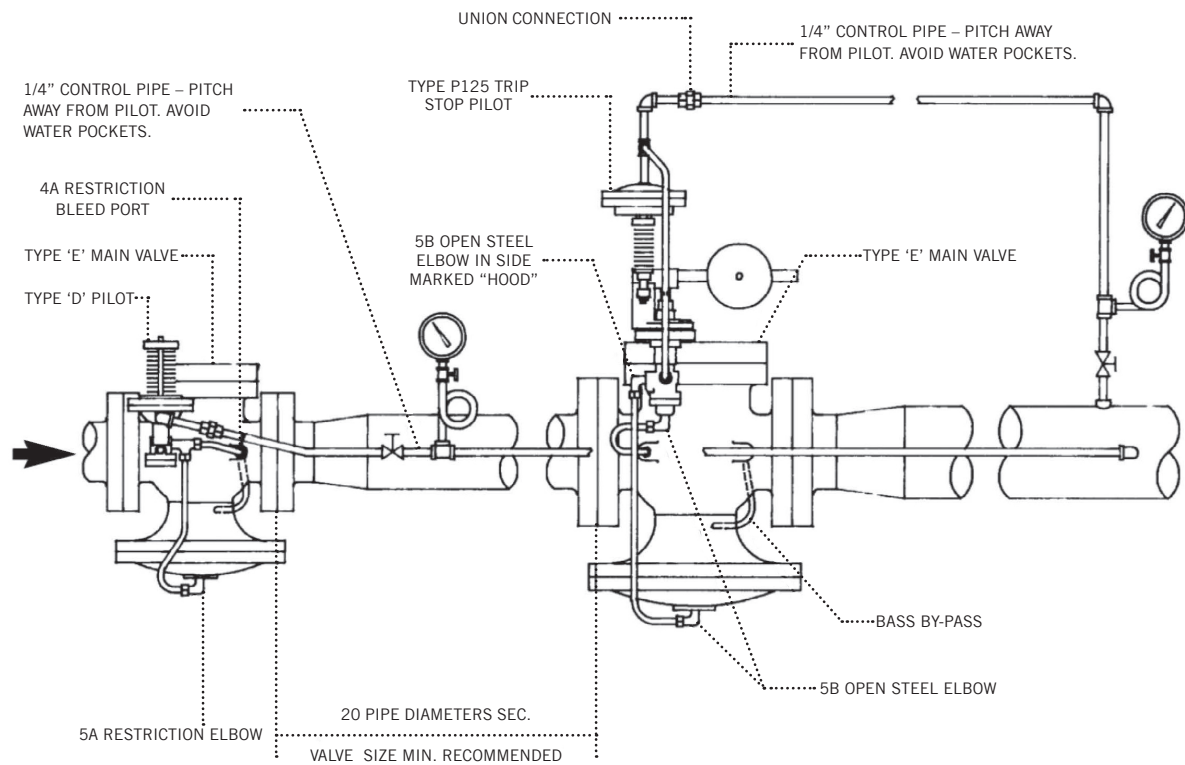

ADVANTAGES:

- Trip valve has to be manually rest.
- Less expensive than relief valve.
- Control accuracy of ED.

TYPE D50A DIRECT OPERATED PRESSURE REDUCING VALVE

APPLICATION:

To reduce a steady or varying inlet pressure to a constant adjustable delivery pressure. Ideal for small flows such as unit heaters and sterilizers.

OPERATION:

Valve is operated by incoming pressure. As delivery pressure nears spring setting on pilot, valve starts to modulate and maintain set pressure.

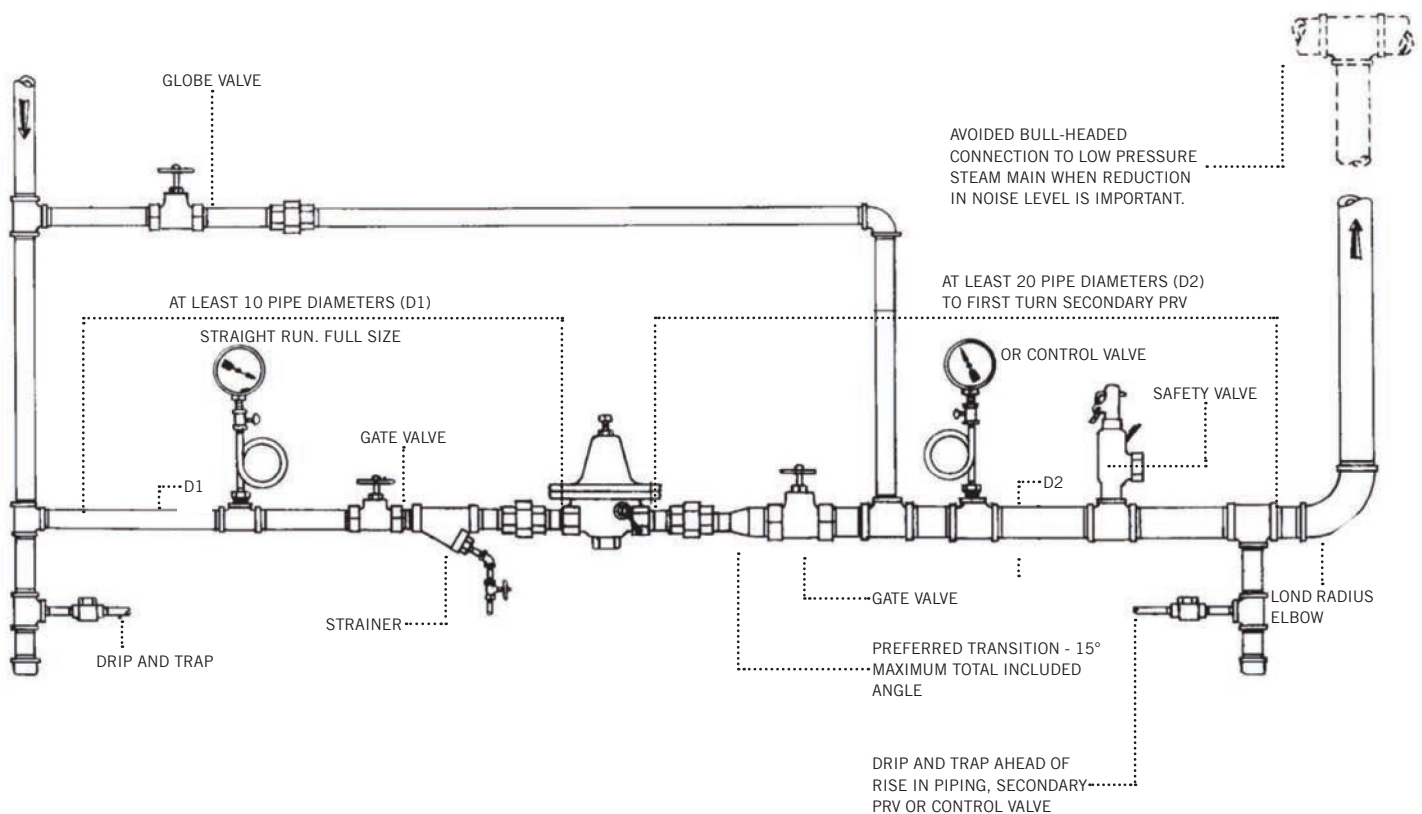

ADVANTAGES:

- Accurate control.
- Available in Cast Iron, Bronze and Stainless Steel.
- Aspirator adjustment for greater sensitivity.

TYPE ED5 PRESSURE REGULATOR FOR ACCURATE CONTROL OF A DEAERATOR

APPLICATION:

To enhance the deaeration of boiler feedwater by accurately controlling the steam pressure and temperature in a deaerator.

OPERATION:

The Type ED5 Pressure Regulator is connected to the Deaerator as shown, with the Type D5 Pilot's Sensing Line connected to the Deaerator. Operation is identical to the Type ED except delivery pressure is sensed in the Deaerator, not the steam piping. The larger, more sensitive diaphragm of the Type D5 Pilot (1 to 25 psig delivery pressure) has twice the accuracy ($\pm 1/2$ psig) of the Type D Pilot (± 1 psig). With the Type D5 Pilot typically set at 5 psig, temperature variation inside the Deaerator is held to ± 1 °F.

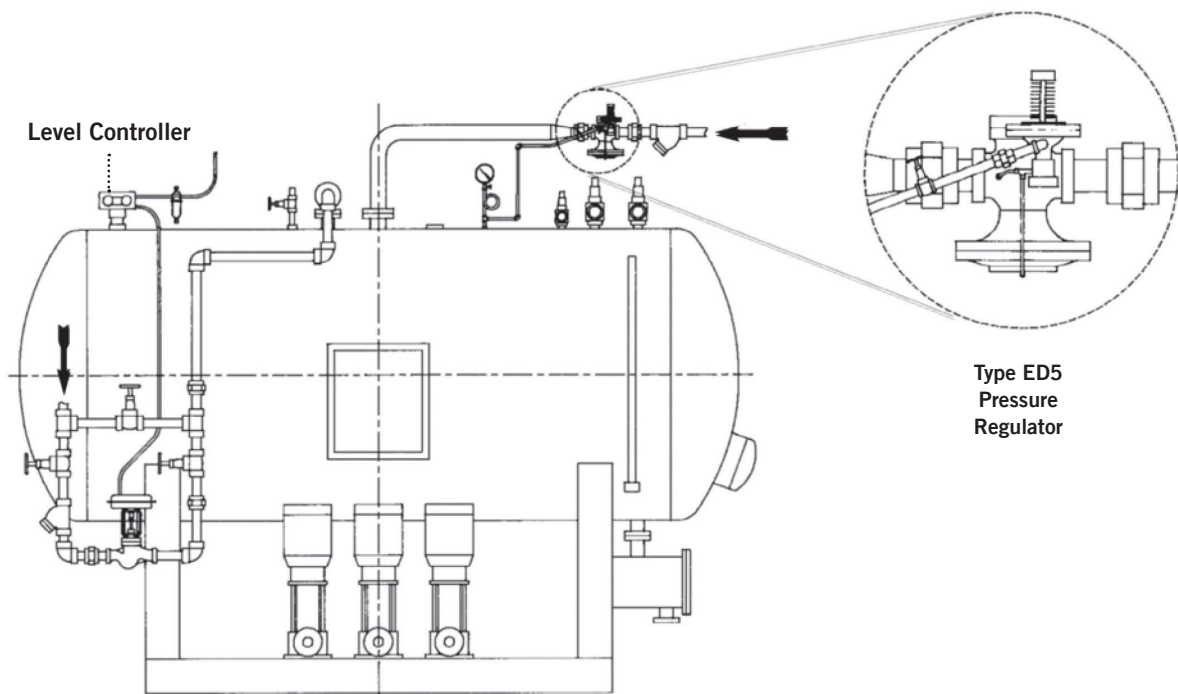

ADVANTAGES:

Self-contained, packless regulator

Increased accuracy for better deaeration

Type E2 substituted if initial steam pressure is between 9 and 15 psig

TYPE E2 SLOW OPENING VALVE

APPLICATION:

When slow opening is required on a low pressure steam system, the E2 can be slowly opened by using a low volume flow control valve.

OPERATION:

System is turned on by activating solenoid, and supplying air to flow control, which sends air loading pressure to diaphragm of E2 valve. Opening time is regulated by adjusting needle valve on flow control. When solenoid is shut off, it bleeds loading air from diaphragm of the E2 valve allowing it to close.

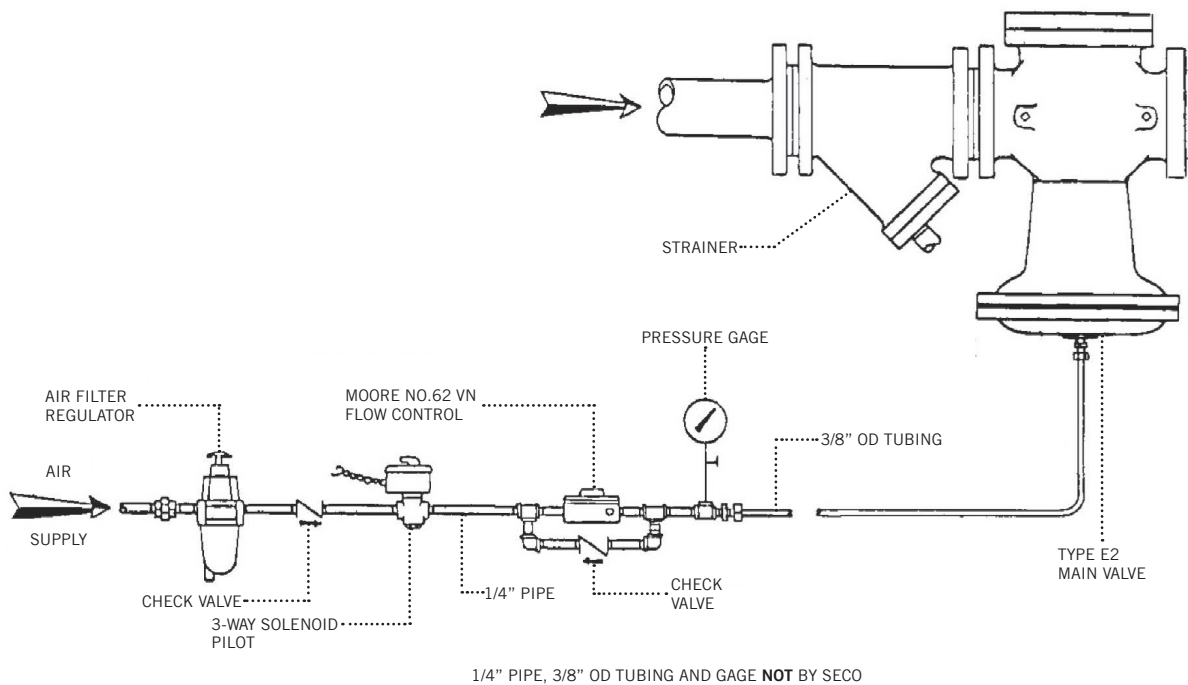

ADVANTAGES:

- Low cost.
- Closes on loss of air.
- Remote controlled.

TYPE ET14 AND ET14D TEMPERATURE REGULATOR

APPLICATION:

To provide temperature control in a storage water heater.

OPERATION:

Steam flowing through the main valve is controlled by the T14 pilot. Variations in temperature at the thermostat opens and closes T14 pilot, which operates the valve. If pressure control is needed to protect heater coils, the D pilot is used.

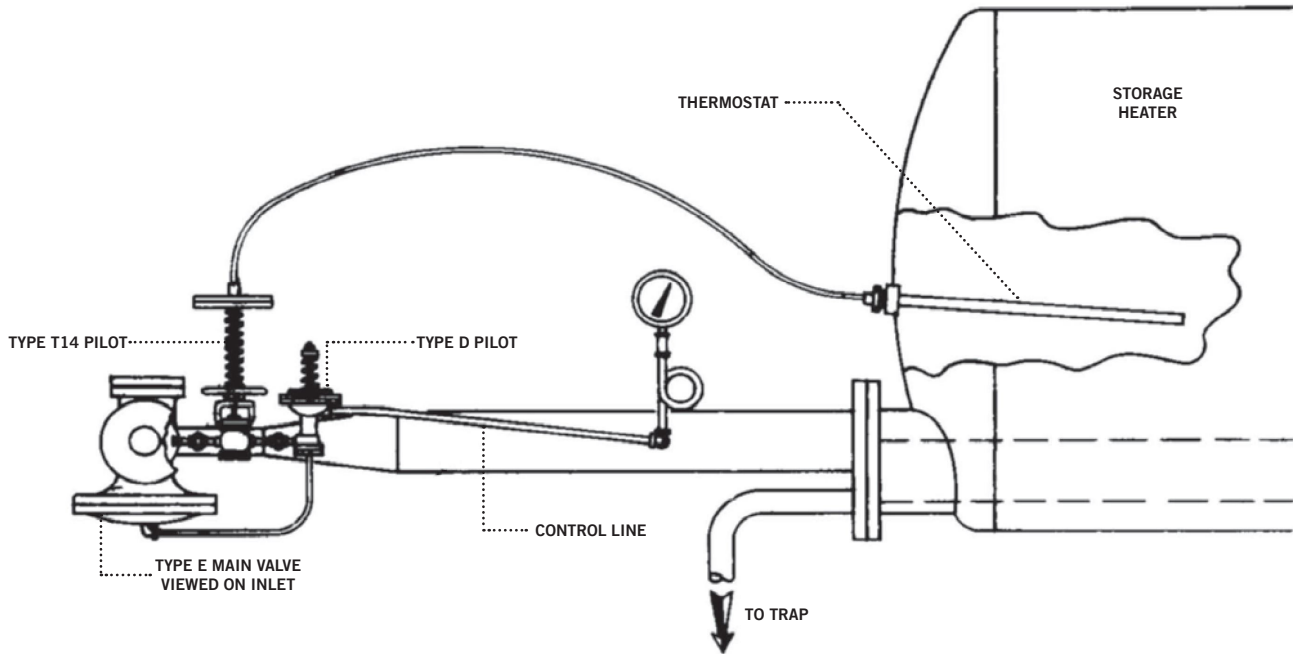

ADVANTAGES:

- Pilot operated accuracy.
- No separate PRV required.
- Many temperature ranges available.
- All packless construction.

TYPE ET124 AND ET134 TEMPERATURE REGULATOR

APPLICATION:

To provide temperature control in a converter or instantaneous heater.

OPERATION:

Steam flowing through the main valve is controlled by T124 or T134 pilot. Steam pressure in the heater is modulated in proportion to temperature and load variations.

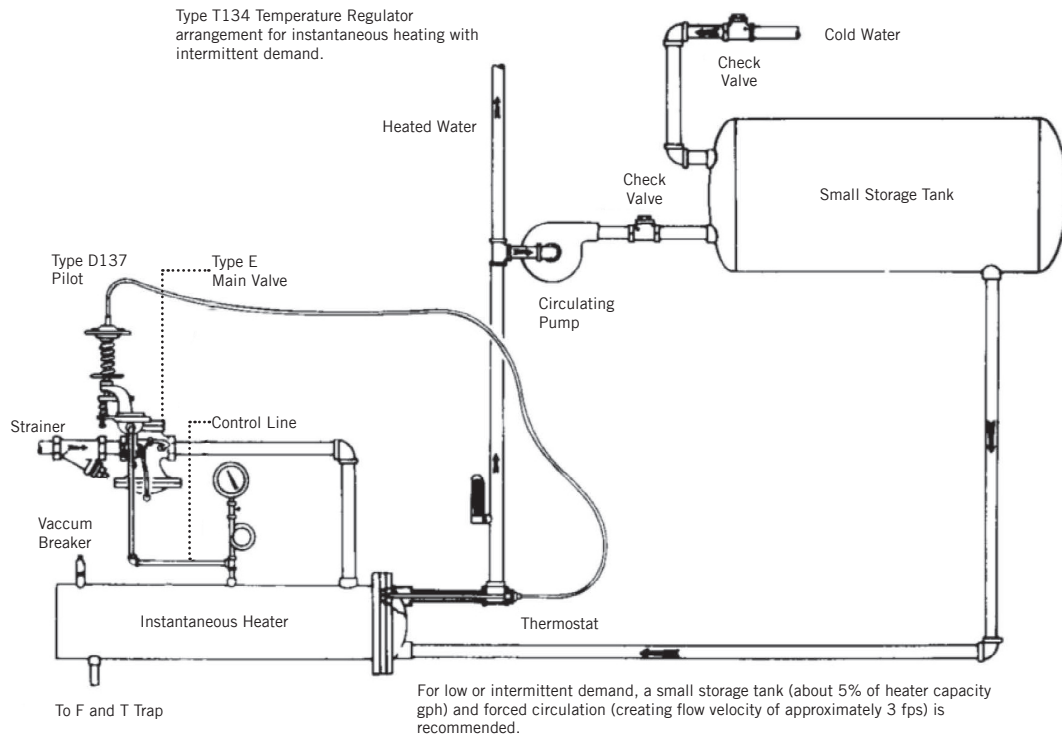

ADVANTAGES:

No separate PRV required.

Pressure sensing anticipates load changes before thermostat sees temperature change.

Standard stock valves.

TYPE ET14D TEMPERATURE REGULATOR

APPLICATION:

To control fuel oil temperature in a storage tank.

OPERATION:

The T14 pilot opens and closes the main valve with slight variations in stored-oil temperature. The D pilot “takes over” to control coil pressure when the T14 pilot opens wide. The thermostat bulb can be raised or lowered by loosening the packing nut and sliding the bulb extension through the packing.

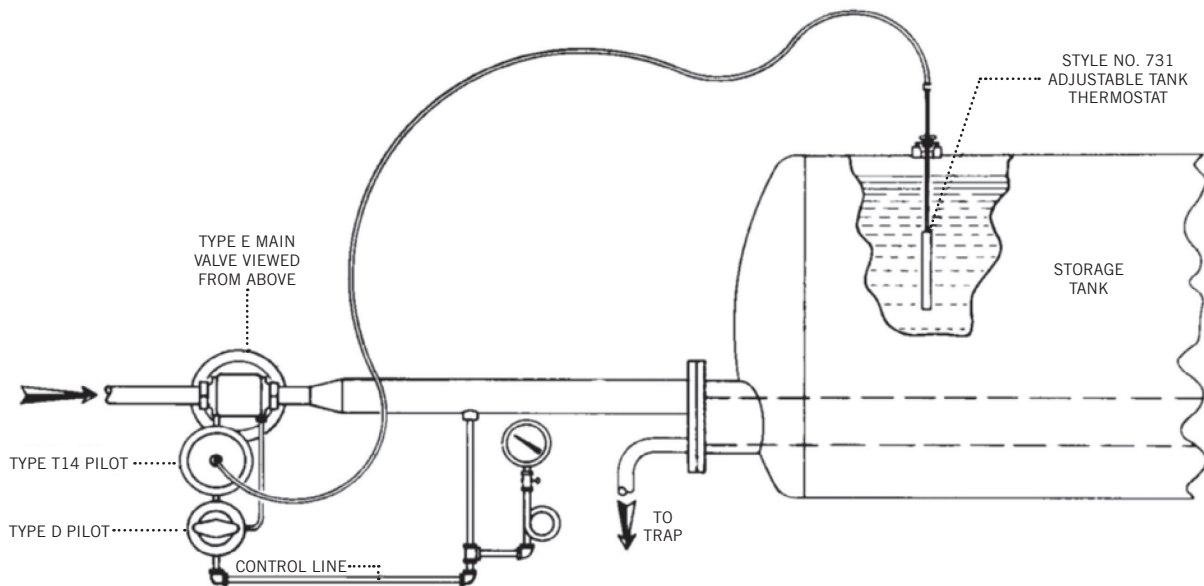

ADVANTAGES:

Permits top-insertion. Bulb can be removed even when tank is full.

Permits adjusting bulb location for best efficiency, as tank level varies.

Minimizes oil carbonation through pressure control.

Combining pressure and temperature regulation in same valve reduces maintenance.

Smaller high pressure line can be used for steam transmission to tank.

TYPE ET14T14 TEMPERATURE REGULATOR

APPLICATION:

To provide temperature control of heating coils and prevent freeze-up, if outside temperature drops below freezing.

OPERATION:

When outside temperature is above freezing, the pilot sensing that temperature is off and the valve is controlled by the pilot sensing inside temperature. If outside temperature drops below freezing, the pilot sensing outside temperature will open the valve regardless of inside temperature.

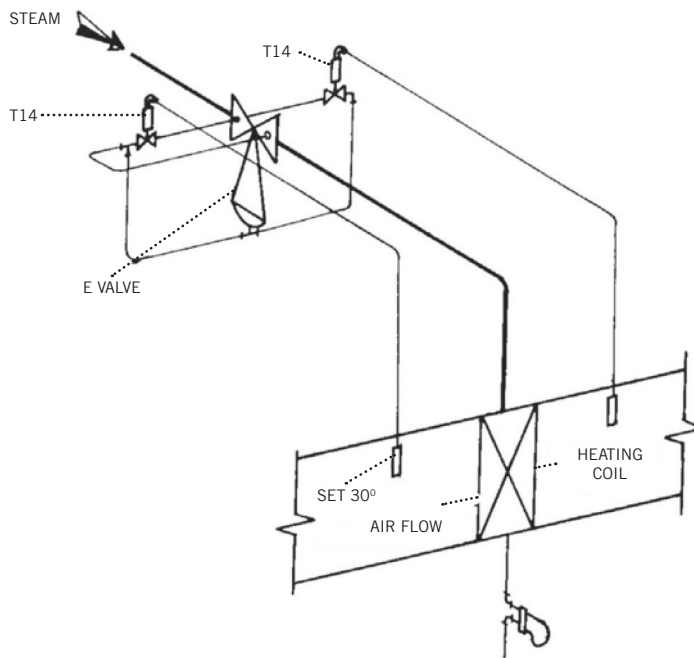

ADVANTAGES:

- One pilot will over-ride other.
- Pilot operated accuracy.
- Self contained

TYPE ET134 TEMPERATURE REGULATOR FOR POULTRY SCALDER

APPLICATION:

To provide self-contained pressure reduction, temperature and pressure control to a Poultry Scalding.

OPERATION:

A Poultry Scalding is essentially an open topped multi-nozzle steam injection heater custom fabricated to suit the customer's requirements. Steam flowing through the **Type E** Main Valve is controlled by the **Type T134 Pilot**. Steam pressure to the injection nozzles is modulated, within the pre-set range of the **T134's** pressure limit spring, in proportion to temperature, typically 140°F., and process variations.

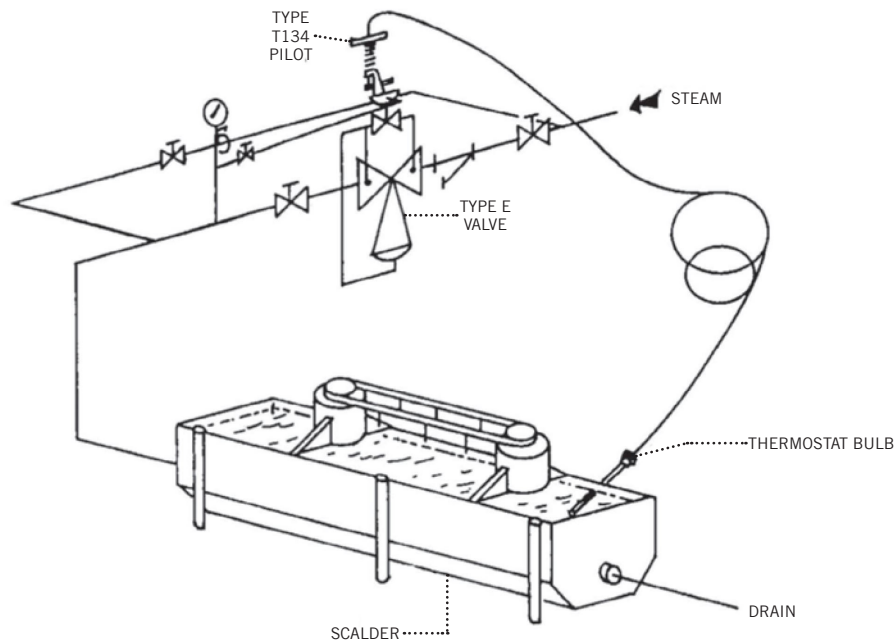

ADVANTAGES:

Self-contained, packless construction.

Provides pressure reduction, temperature and pressure control in a single unit.

Adaptable to existing scalders utilizing Pneumatic Temperature Controllers by substituting the appropriate Type T134 Pilot in place of the Type A Pilot.

SERIES 2000 DIRECT OPERATED TEMPERATURE REGULATOR FOR STORAGE HEATER

APPLICATION:

To provide economical temperature control of a storage heater.

OPERATION:

Steam (or other heating medium) is supplied to the Series 2000 valve body. Variations in temperature at the bulb opens and closes the valve thus maintaining the desired temperature..

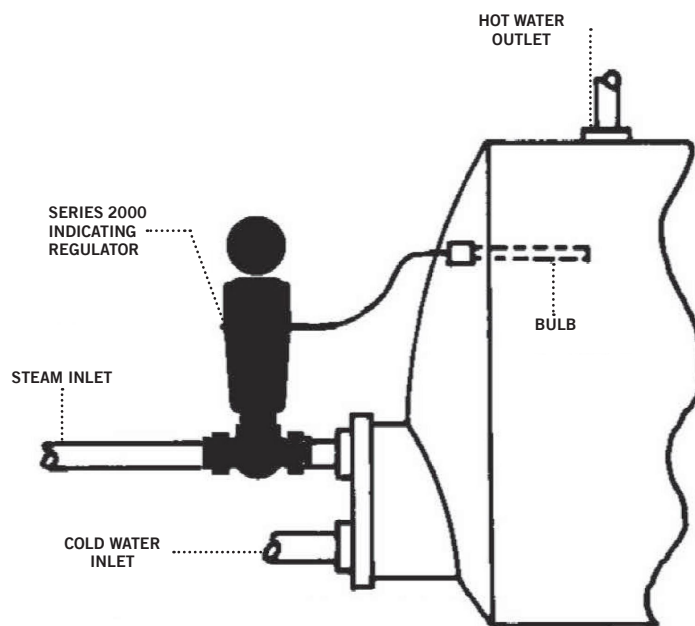

ADVANTAGES:

- Inexpensive.
- Uncomplicated
- Ideal when load fluctuations are minimal
- Self-contained

SERIES 2000 DIRECT OPERATED TEMPERATURE REGULATOR FOR PLATE HEATER

APPLICATION:

To provide economical temperature control of an open topped tank heater (ie: plating tank).

OPERATION:

Operation: Steam (or other heating medium) is supplied to the Series 2000 valve body. The bulb is suspended over the top of and into the tank. Variations in temperature at the bulb opens and closes the valve thus maintaining the desired temperature in the tank.

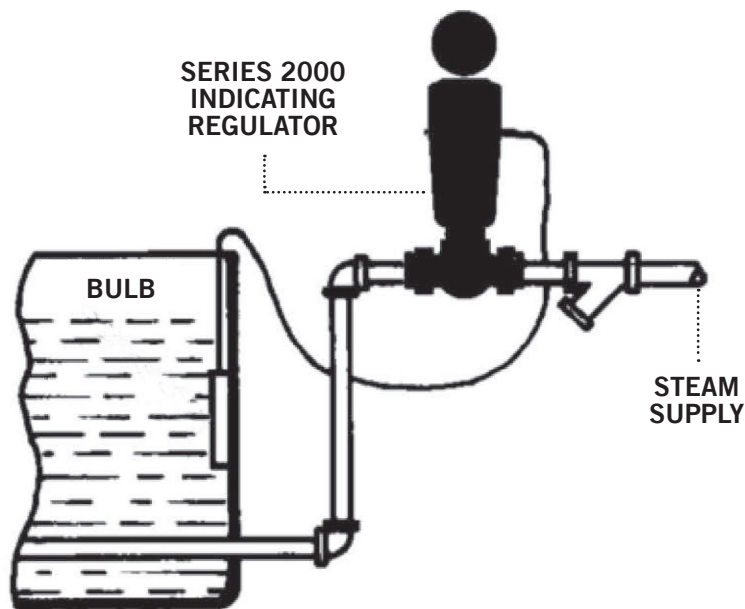

ADVANTAGES:

- Inexpensive.
- Uncomplicated
- Self-contained

SERIES 2000 DIRECT OPERATED TEMPERATURE REGULATOR FOR ENGINE JACKET COOLING

APPLICATION:

To provide engine jacket cooling.

OPERATION:

Reverse acting Series 2000 is installed in the engine's cooling system as indicated in the diagram. The bulb senses the engine's coolant temperature and, when the coolant temperature reaches the Series 2000's set point, the valve opens and modulates to maintain the desired coolant temperature.

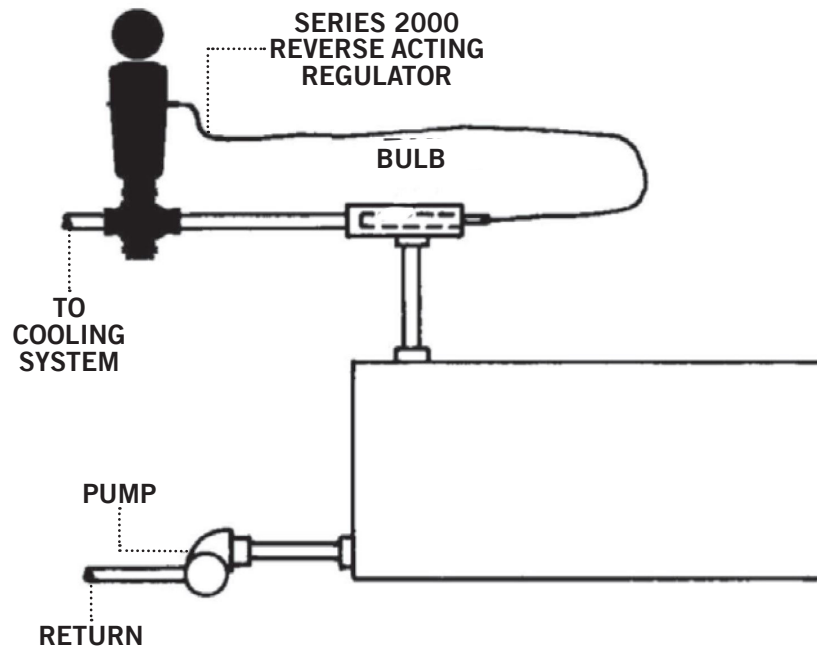

ADVANTAGES:

- Inexpensive.
- Uncomplicated
- Self-contained

SERIES 2000 DIRECT OPERATED TEMPERATURE REGULATOR FOR LIQUID COOLING TANK

APPLICATION:

To operate a liquid cooling tank.

OPERATION:

As the warm liquid to be cooled reaches the Series 2000's bulb, the valve opens by admitting coolant (brine) into the cooler's coils. The Series 2000 modulates about its set point, thereby controlling the temperature of the cooled liquid.

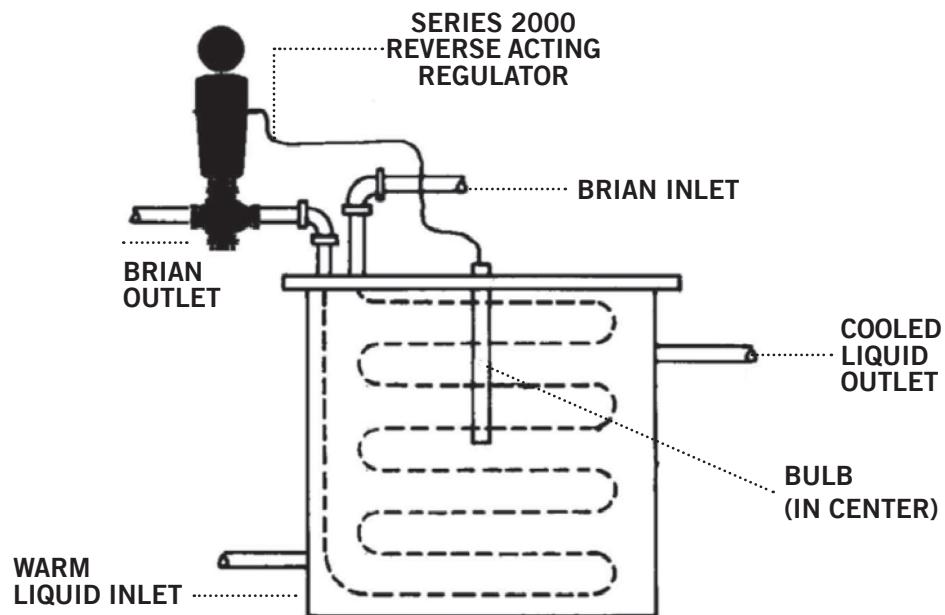

ADVANTAGES:

- Inexpensive.
- Uncomplicated
- Self-contained

SERIES 2000 DIRECT OPERATED TEMPERATURE REGULATOR FOR THREE-WAY BLENDING/MIXING

APPLICATION:

To operate as a 3-way blending / mixing valve.

OPERATION:

The Series 2000 Three Way valve is installed as indicated in the diagram. In this case, cold water enters the valve from the left while the heated boiler water enters from the bottom. The bulb senses the temperature in the storage tank and modulates the amounts of cold and hot water blended (mixed) to maintain the desired temperature of the water in the storage tank.

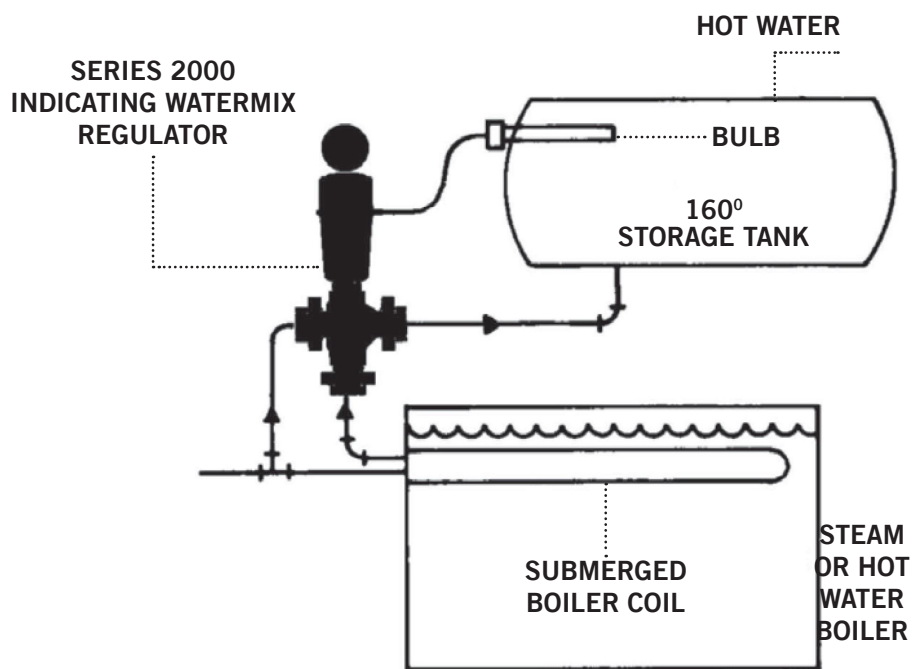

ADVANTAGES:

Inexpensive.

Uncomplicated

Self-contained

SERIES 2000 DIRECT OPERATED TEMPERATURE REGULATOR FOR THREE-WAY DIVERTING

APPLICATION:

To operate as a 3-way diverting valve.

OPERATION:

Engine coolant is supplied to the left, bottom discharge is returning to the engine and right discharge is to cooler. Engine coolant is returned to the engine until it reaches the valve's set point. At that point, the valve starts modulating between returning engine coolant to the engine and discharging to the cooler to maintain the desired temperature.

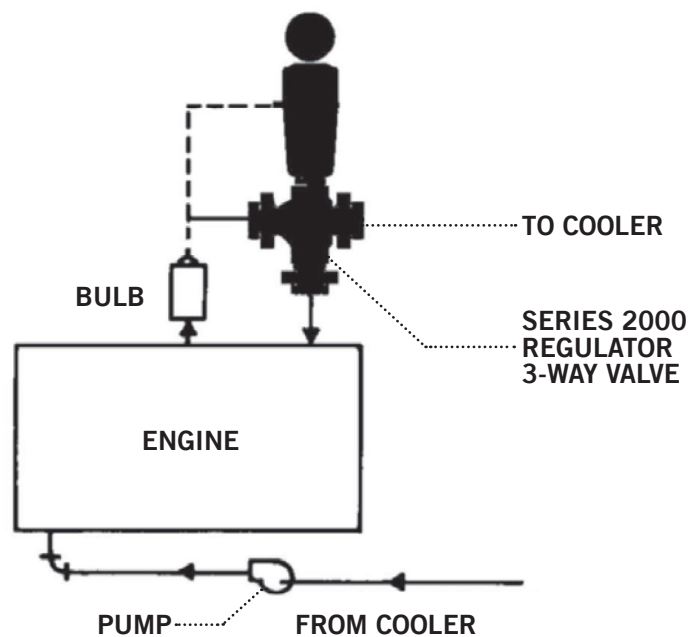

ADVANTAGES:

- Inexpensive.
- Uncomplicated
- Self-contained

TYPE EAT61 AIR CONTROLLED TEMPERATURE REGULATOR

APPLICATION:

To provide fast accurate control on instantaneous heaters and difficult process applications.

OPERATION:

Temperature variations at thermostat bulb of T61 pilot changes its output air signal going to A series pilot. The changing air signal positions the A pilot and main valve to maintain temperature setting.

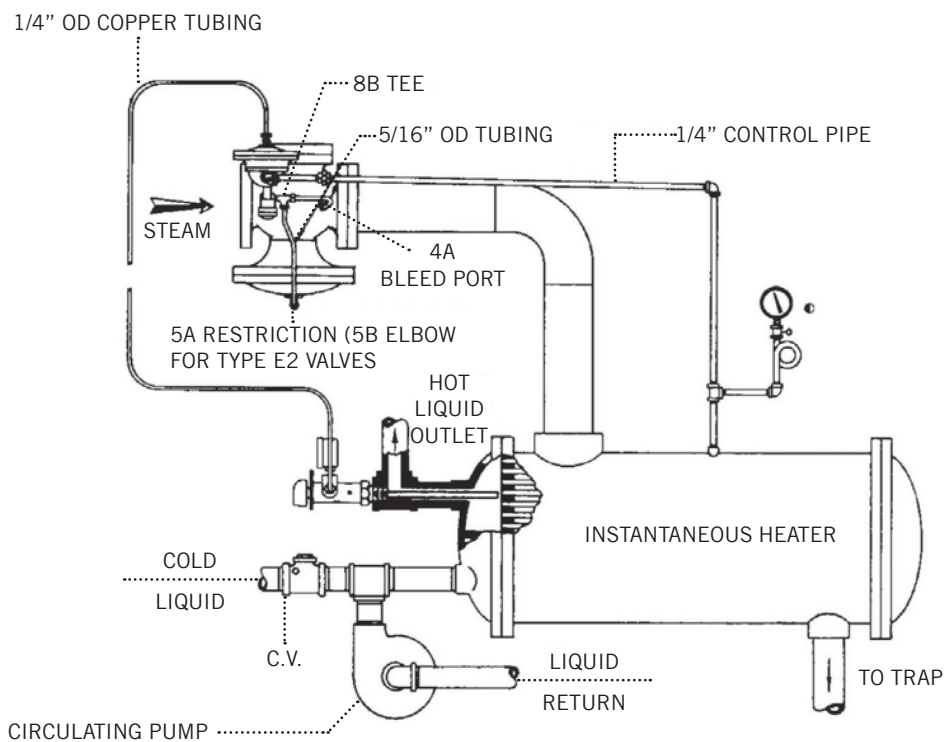

ADVANTAGES:

T61 and A pilot combine for cascade type control.

Accurate sensitive bi-metallic thermostat.

Low air consumption.

TYPE EA TEMPERATURE REGULATOR FOR REMOTE THERMOSTAT CONTROL

APPLICATION:

To provide indoor-outdoor temperature control of hot water temperatures in a heating system.

OPERATION:

The remote bulb thermostat on the master controller provides a pneumatic feed-back based on outside air temperature. The pneumatic feed-back from the master controller raises or lowers the set point of the sub-master controller, which puts out a varying signal to the Spence EA regulator to maintain proper water temperature.

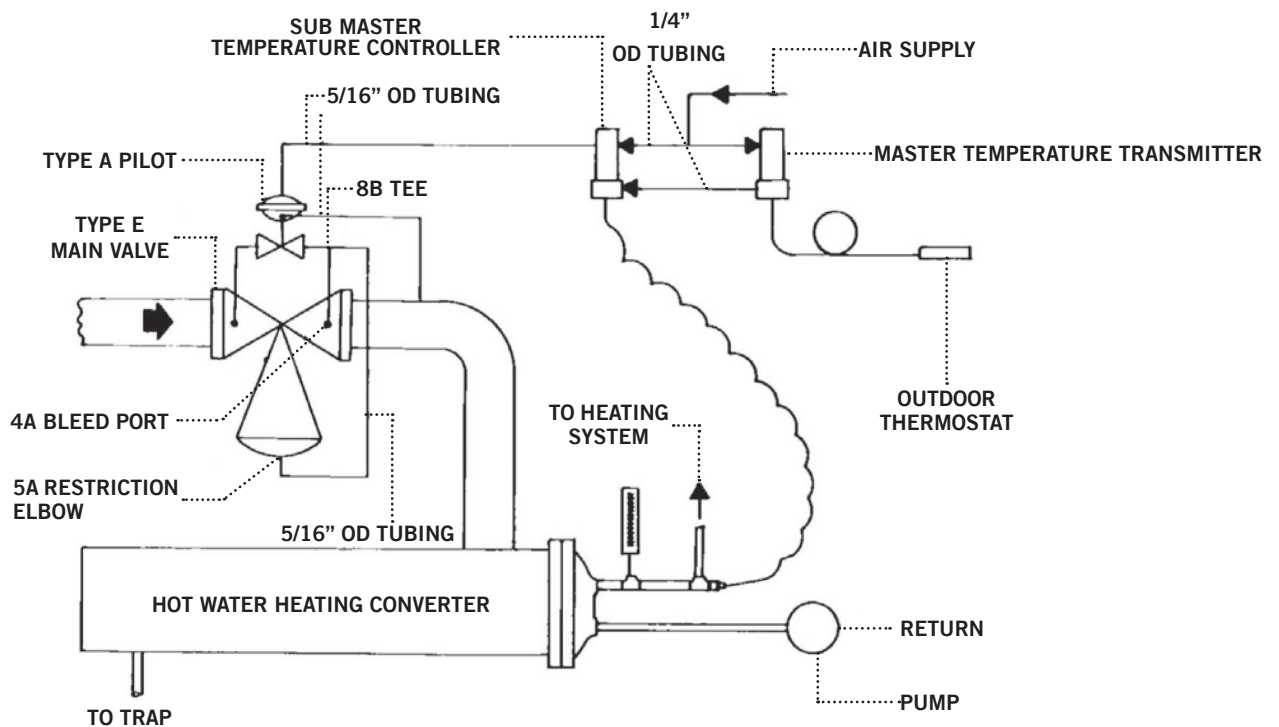

ADVANTAGES:

- Accurate temperature control.
- Economical, water heated only when needed.
- Standard valve and pilot.

TYPE ET134 SELF-CONTAINED TEMPERATURE REGULATOR FOR STARCH MIXER

APPLICATION:

To provide accurate temperature control with pressure limitation in a Starch Mixer for corrugated adhesive usage.

OPERATION:

A Starch Mixer is essentially an open topped, agitated sparge tube storage heater, in which the adhesive is prepared before being placed in storage. The temperature probe of a Type T134 Temperature Pilot is placed in an active area of the Starch Mixer. Once activated, the ET134 flows steam to the heater until either the proper temperature or pressure limit is reached, then the ET134 closes, opens or throttles to maintain its preset temperature or pressure limit.

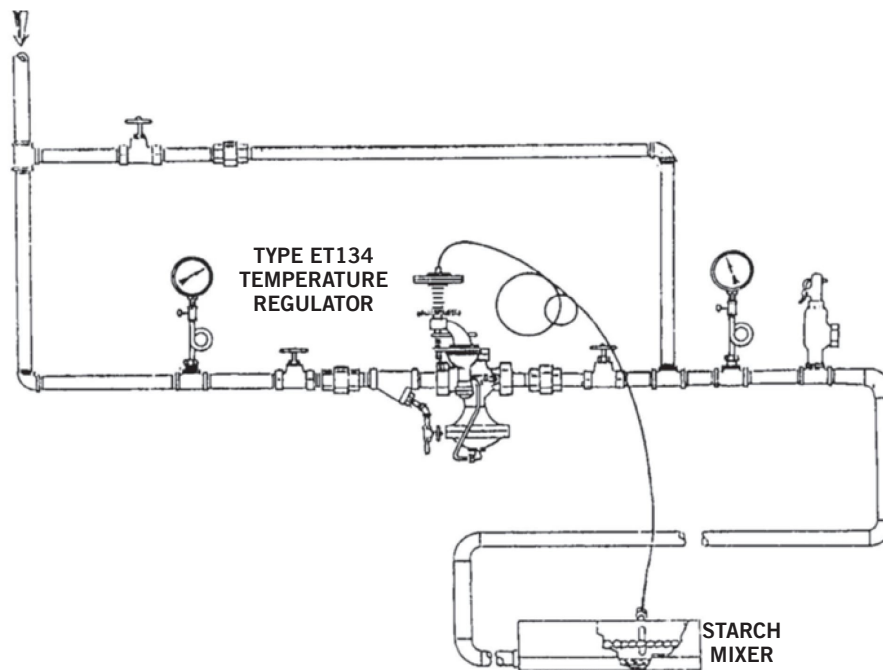

ADVANTAGES:

Self-contained packless construction.

If electronic activation of a remotely located regulator is needed, a Type M Pilot can be added, making an EMT134

No separate PRV needed

TYPE ET124A VISCOSITY/TEMPERATURE REGULATOR

APPLICATION:

To provide increased economy by controlling the viscosity of the fuel oil to a burner unit while, at the same time, retaining conventional self-contained temperature regulation for emergency use in the event of pneumatic system failure.

OPERATION:

In normal operation the 1/4" gate valve supplying the Type T124 Pilot is closed, the 1/4" gate valve supplying the Type A Pilot is open. The Norcross Viscosity Meter samples the viscosity of the fuel oil discharge of the fuel oil heater and adjusts the 3 to 15 psi air loading signal to the Type EA Regulator. The correct steam pressure and flow is supplied to the fuel oil heater to optimize fuel oil viscosity for burner unit efficiency. In the event of a pneumatic system failure, closing the 1/4" gate valve supplying the Type A Pilot and opening the 1/4" gate valve supplying the Type T124 Pilot provides conventional temperature control by a Type ET124 Temperature Regulator. (see Application Guide C1-2)

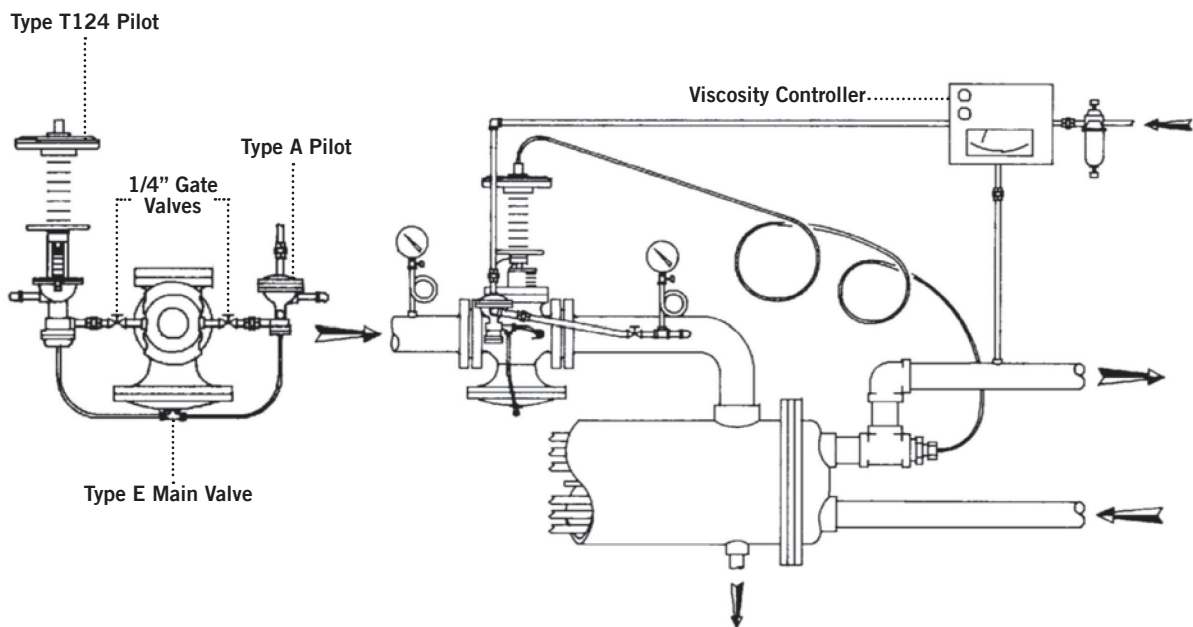

ADVANTAGES:

Increased fuel oil economy

Self-contained Temperature Regulator available for stand-by service

TYPE EQ BACK PRESSURE REGULATOR

APPLICATION:

To maintain pressure in a flash tank so that steam can be used in low pressure main.

OPERATION:

When steam pressure in the flash tank increases above the Q pilot setting, the E valve will open and vent the excess to maintain correct pressure.

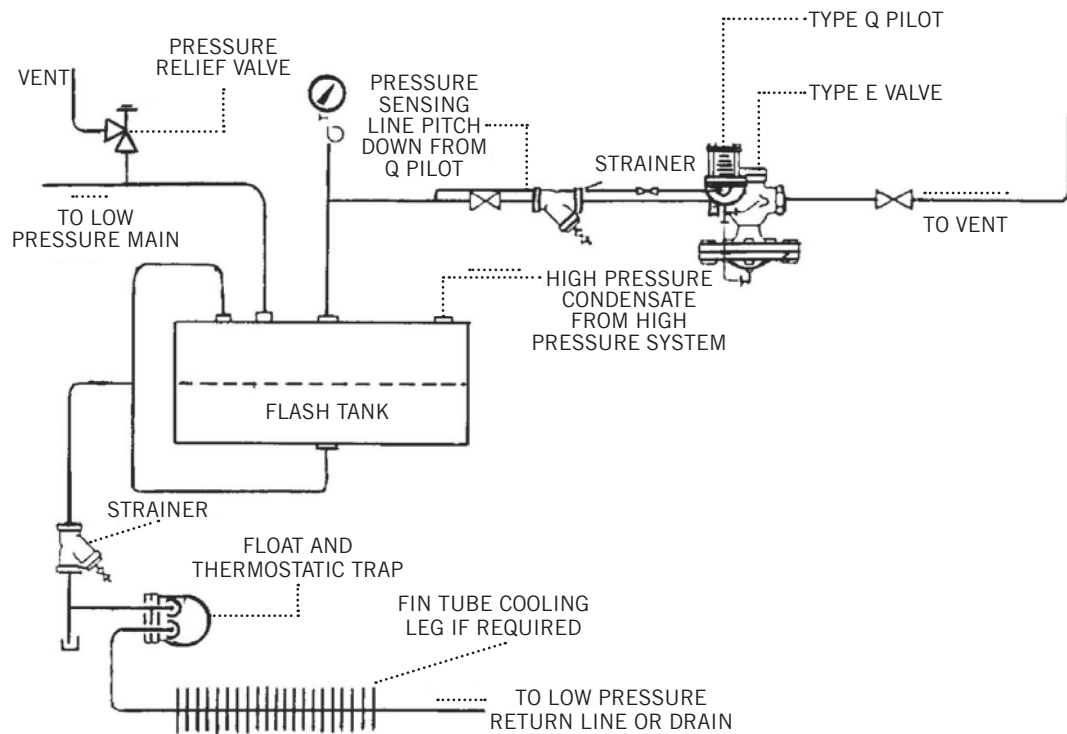

ADVANTAGES:

Accurate control.

Saves money by using flash steam.

TYPE EQ BACK PRESSURE VALVE WITH FLOW CONTROL ORIFICE

APPLICATION:

To provide a valve that will limit flow and provide steam at a constant pressure.

OPERATION:

An orifice is sized for a known flow at a given pressure drop and is fitted in the upstream piping of the Back Pressure Valve. The Q pilot is set for the pressure required at the outlet of the orifice. If the pressure at the outlet of the orifice drops, the valve will start to close to maintain the pressure and flow.

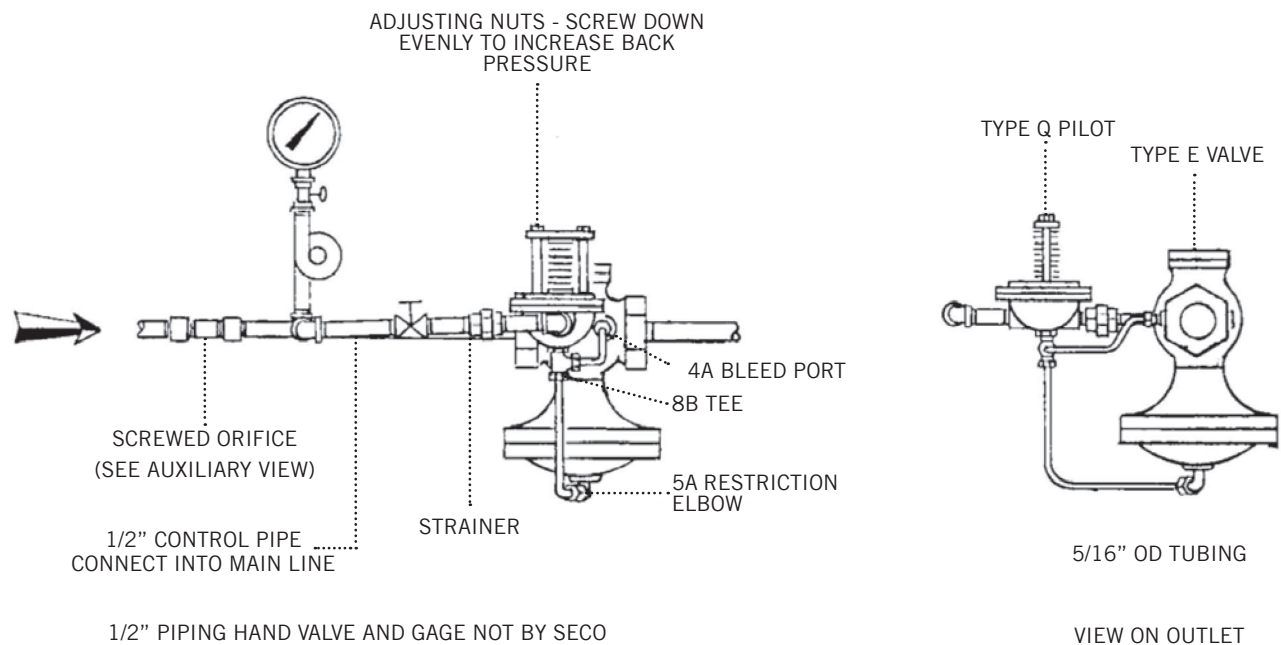

ADVANTAGES:

- Standard Spence Valves.
- Easily adjustable.

TYPE EN33 DIFFERENTIAL REGULATOR

APPLICATION:

To regulate the atomizing steam pressure to an oil burner by pre-setting that amount higher than the oil pressure.

OPERATION:

The steam pressure under the diaphragm of the Type N33 Pilot is balanced by the oil pressure and the adjusting spring on top. Once set, the adjusting spring force is constant. Therefore, as the combustion control valve raises the oil pressure, the regulator raises the steam pressure until the pilot diaphragm is again in balance.

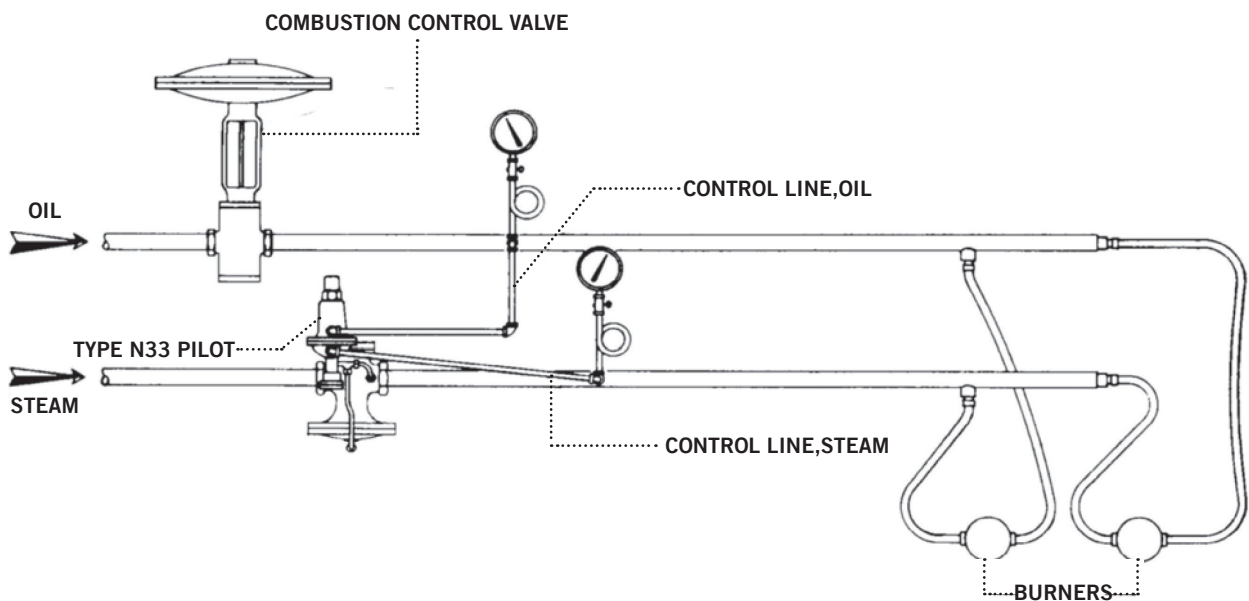

ADVANTAGES:

Accurate pilot control.

Valve can be balanced for greater rangeability.

Self contained.

TYPE N6 DIFFERENTIAL PRESSURE VALVE

APPLICATION:

To maintain pump discharge pressure at a constant differential above boiler steam pressure.

OPERATION:

The desired differential is made by the adjusting spring. The boiler feed pressure will then be maintained by the N6 at a constant pressure above the steam drum pressure by modulating the quantity of water by-passed to pump suction.

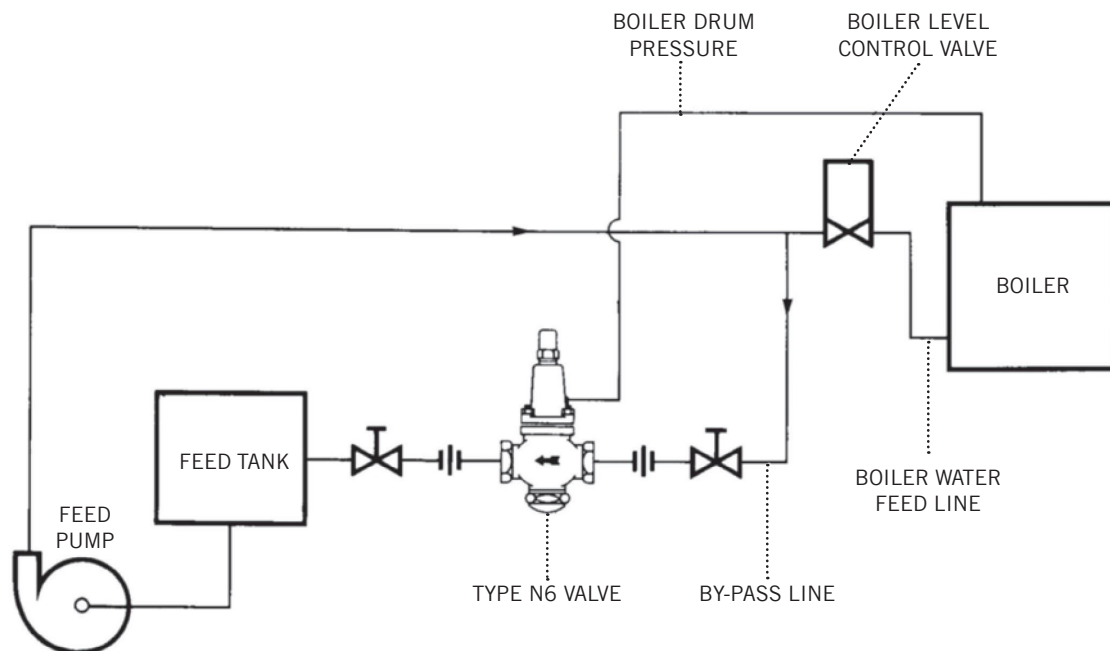

ADVANTAGES:

- Self contained.
- Easily adjustable.
- Stainless steel trim.

STEAM ATOMIZING AIR OPERATED DESUPERHEATER

APPLICATION:

Spence steam atomizing desuperheaters are designed to reduce and control the temperatures of superheated steam by the controlled injection of a cooling water mist.

OPERATION:

Water and steam are injected into a superheated steam line through the injector nozzle. The nozzle is designed to break the water into a fine mist to be easily absorbed by the oncoming steam.

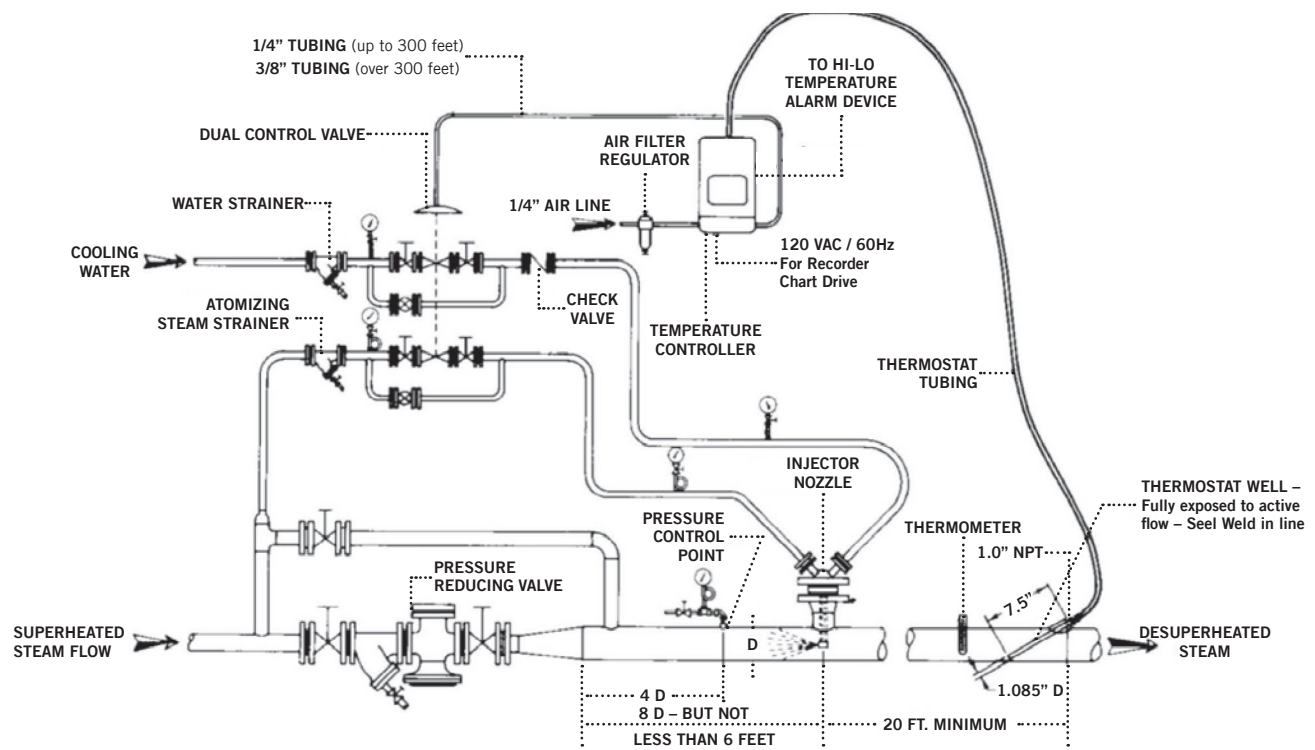

ADVANTAGES:

- Complete package by Spence.
- Spence Pressure Reducing Valve available.
- Many sizes available.

MECHANICAL ATOMIZING AIR OPERATED DESUPERHEATER

APPLICATION:

Spence mechanical atomizing desuperheaters are designed to reduce and control the temperature of superheated steam by the controlled injection of a finely dispersed spray of cooling water.

OPERATION:

Water is injected into a superheated steam line through the injector nozzle. The nozzle is designed to break the water into a fine mist to be easily absorbed by the oncoming steam.

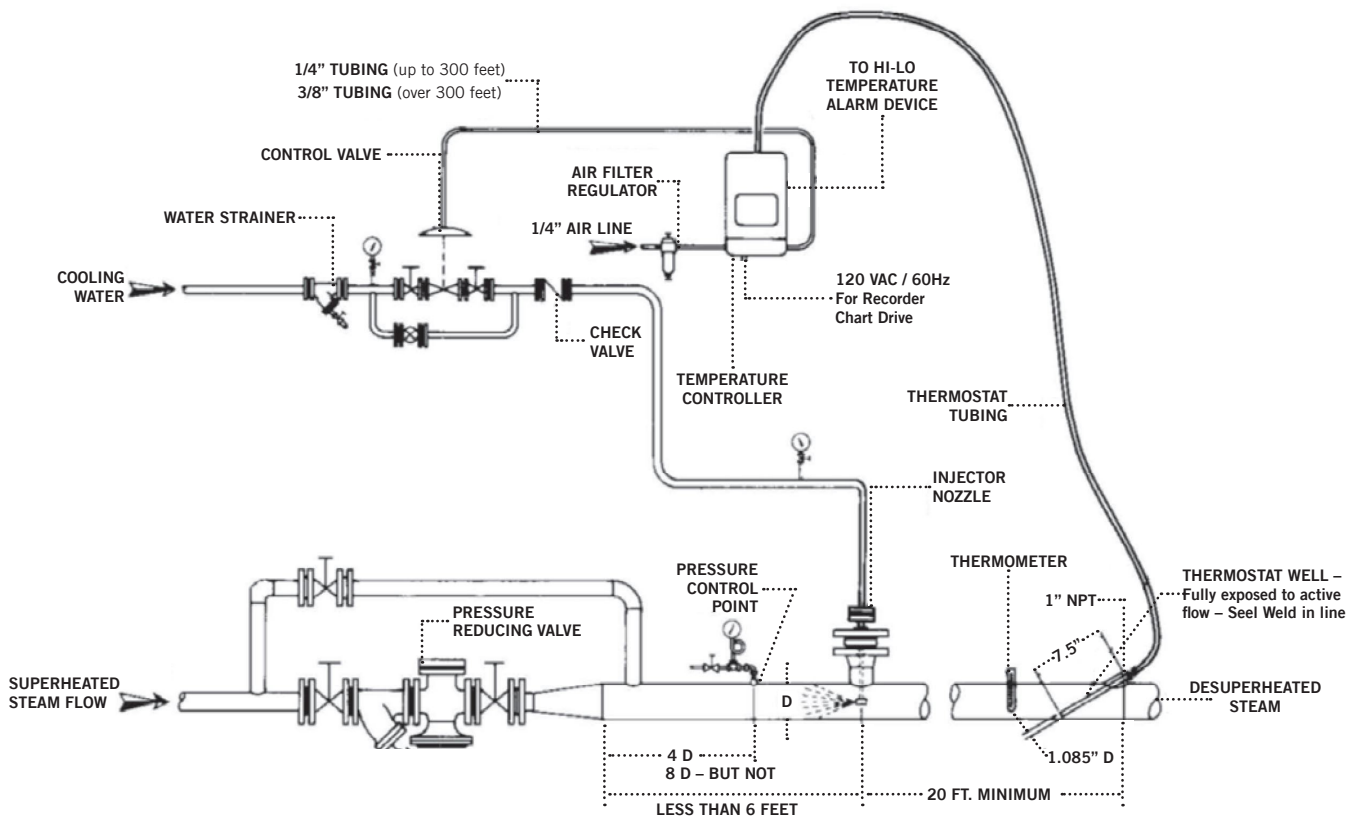

ADVANTAGES:

- Complete package by Spence.
- Spence Pressure Reducing Valve available.
- Many sizes available.

PRESSURE REGULATOR WITH MUFFLING ORIFICE

APPLICATION:

The Spence muffling orifice reduces the generation of pressure regulator noise at its source. It provides an economical means of attenuating high flow PRV noises by 6 - 20 dBA.

OPERATION:

The muffling orifice consists of a steel plate with primary orifices, to which is welded a stainless steel plate with secondary orifices. The plate is installed in the expanded downstream piping, and creates the desired back pressure on the PRV for maximum attenuation.

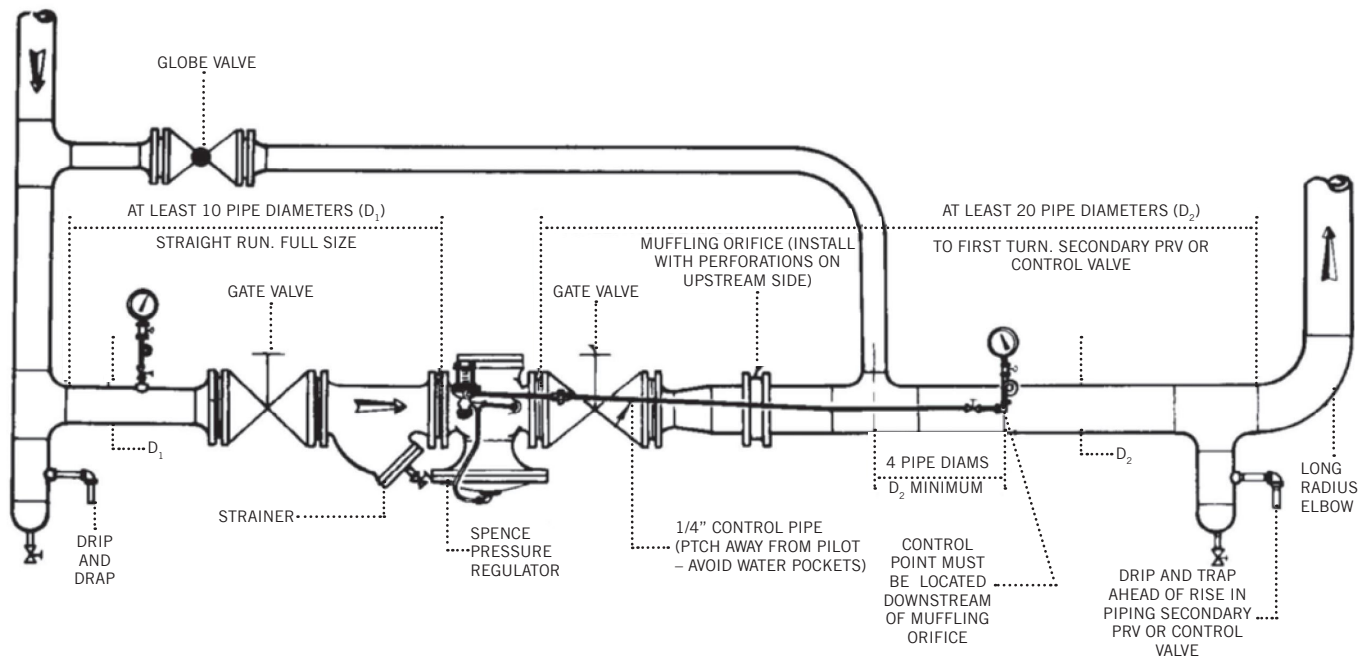

ADVANTAGES:

- Inexpensive.
- Maintenance free.
- Capacity of valve not reduced.
- Ease of installation.

PRESSURE REGULATOR WITH NOISE SUPPRESSOR

APPLICATION:

The Spence Noise Suppressor is designed to attenuate the noise generated by a pressure reducing station. These devices are particularly effective in limiting the propagation of valve-generated noise into the downstream piping. Being of the dissipative reactive type, they are effective over a broad frequency band (up to 12,000 Hz). Depending upon flow and piping configuration, noise attenuation of up to 20 decibels is obtainable.

OPERATION:

Installed at the reducing valve outlet, the required pipeline expansion takes place within the noise suppressor. This expanded outlet feature eliminates the expense and noise often associated with separate expansion fittings. A reflector assembly improves performance by increasing the interaction of flow and acoustic material. The straight through design minimizes pressure drop, permitting normal valve sizing.

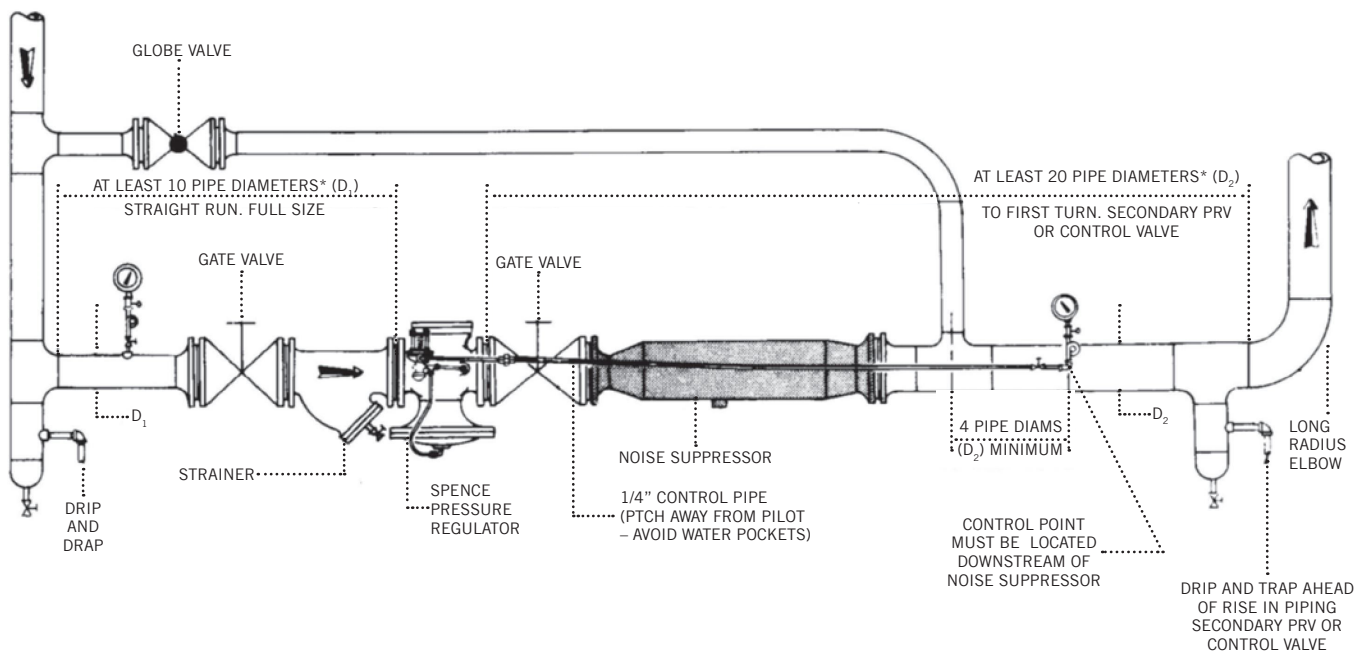

ADVANTAGES:

- Maintenance free.
- Standard Spence valves used.
- Capacity of valve not reduced.

*Recommended distance

TYPE J CONTROL VALVE AND LIQUID LEVEL CONTROLLER FOR BOILERS

APPLICATION:

To provide water to a boiler at all times, even if water in condensate tank falls too low.

OPERATION:

As the level in the condensate receiver increases, an output signal from the pilot controller causes the number one J control valve to open and the number two control valve (make-up) to close.

As the level continues to increase, valve number one fully opens, admitting water from the condensate receiver to the boiler feed pump, valve two simultaneously closes, cutting off the soft water make-up supply.

Should the level in the condensate receiver decrease, reverse action of the above occurs and, at low level, all water to the boiler feed pump is obtained from the soft water make-up supply.

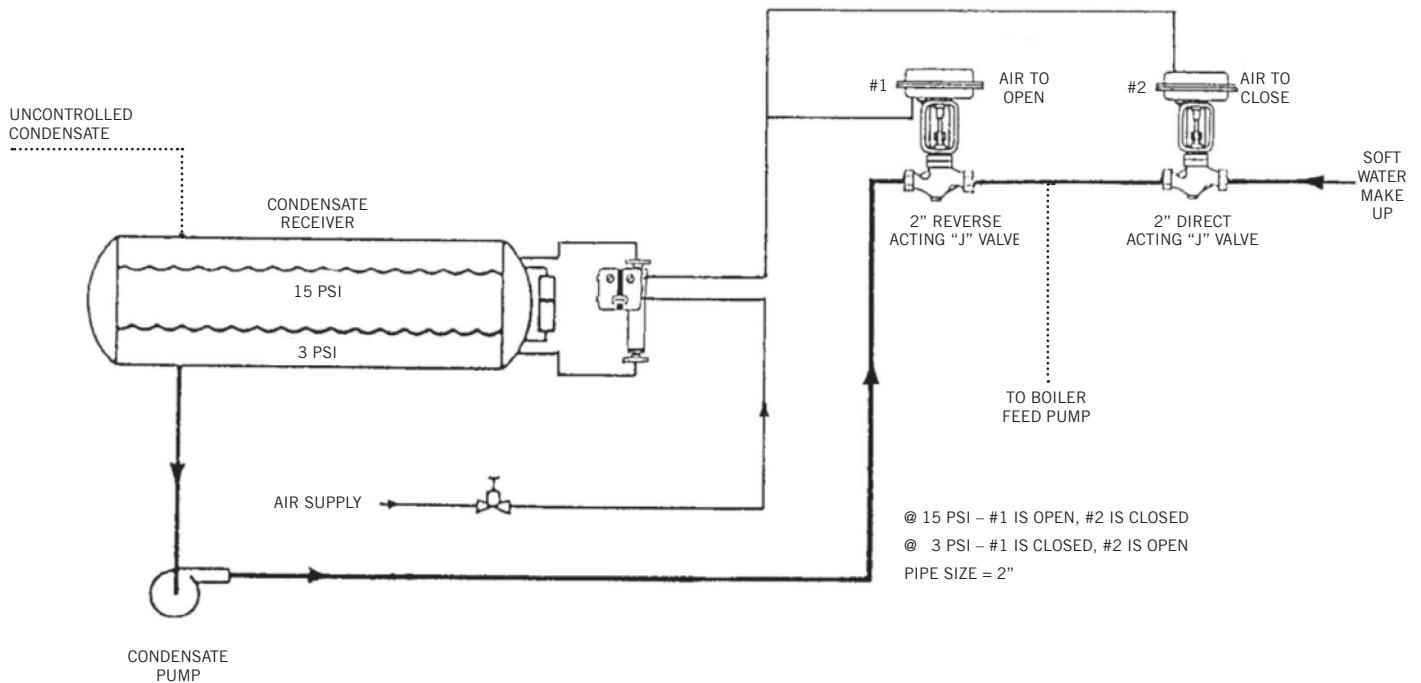

TYPE J CONTROL VALVE WITH ELECTRO-PNEUMATIC POSITIONER FOR COMPUTERIZED COGENERATION CONTROL

APPLICATION:

To interface either a computerized cogeneration control, or electronic controller, to a turbine exhaust make-up valve in order to control the generating turbine's exhaust pressure and flow for secondary steam usage.

OPERATION:

A pre-programmed computer, or electronic controller receiving a 4-20 MA signal from a P/I Transmitter, is used as the controlling device for a Type J Control Valve with an electro-pneumatic positioner opening the by-pass line to the extent necessary to maintain the desired operating conditions.

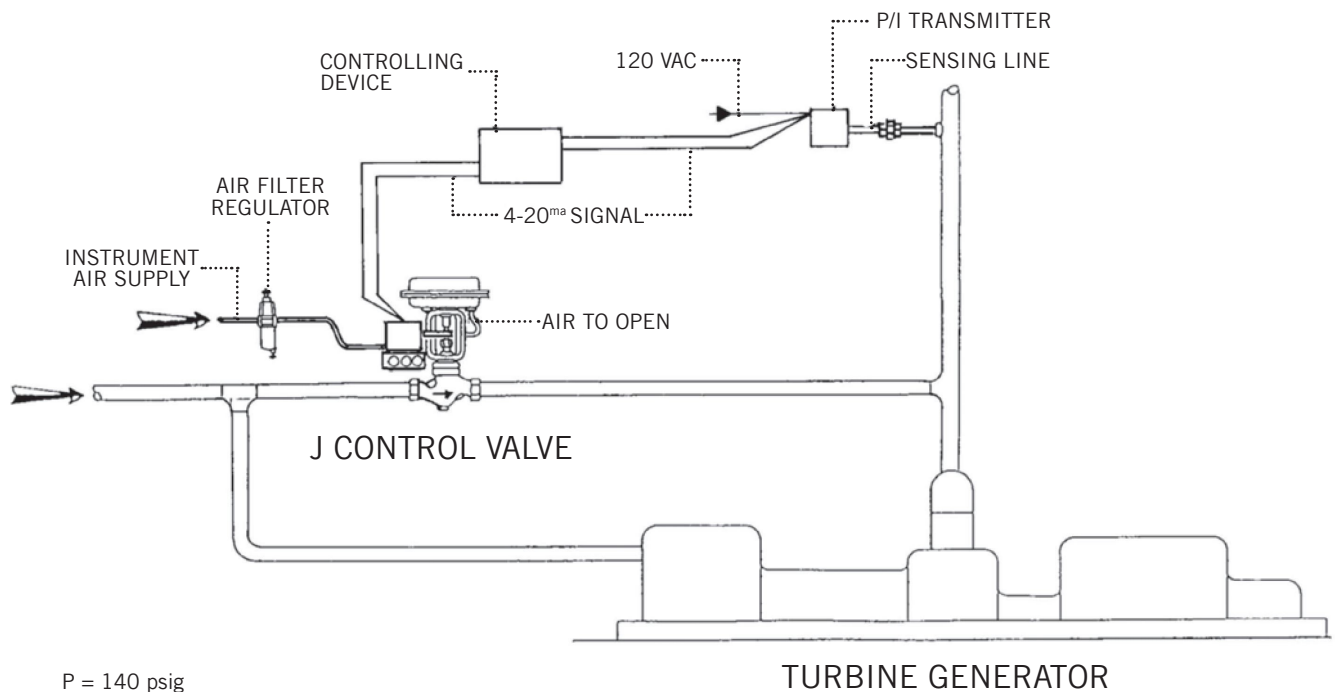

P = 140 psig
P¹ = 17 psig
W² = 8000 lbs/hr
2" J Valve, 1 3/4" Port

TYPE J CONTROL VALVE FOR LEVEL/MAKE-UP ON A DEAERATOR

APPLICATION:

When insufficient condensate to meet the demand for boiler feedwater is returned to the deaerator, the make-up water control valve is opened to satisfy this requirement.

OPERATION:

When the Deaerator's Pneumatic Level Controller senses low water level, it sends a proportional 3 to 15 psia pneumatic signal to the Type 'J' Control Valve. The Type 'J' Control Valve responds by opening, closing or modulating the flow of raw make-up water into the Deaerator, thereby satisfying the demand for boiler feedwater.

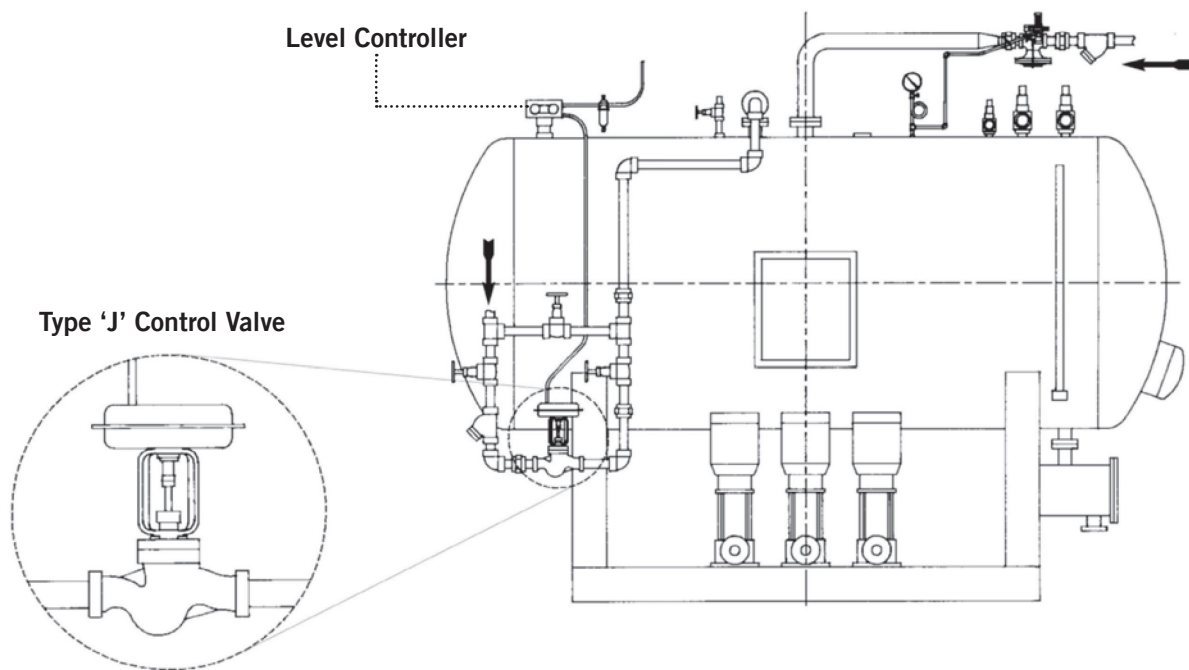

ADVANTAGES:

Precise control of make-up water

The standard modified equal percent plug contour provides superior throttling action

SECTION V
REFERENCE AND
PIPING DESIGN

GLOSSARY OF TERMS

REPRINTED COURTESY FLUID CONTROLS INSTITUTE

PRESSURE REGULATOR - A self-contained device, either pilot or direct operated, in which power to position the valve closure member is provided by the pressure of the controlled variable.

PRESSURE REDUCING REGULATOR - A device that controls and responds to changes in its outlet pressure.

BACK PRESSURE REGULATOR - A device that controls and responds to change in its inlet pressure.

DIFFERENTIAL PRESSURE REGULATOR - A device that maintains a constant differential pressure between a reference pressure and the pressure of the controlled fluid.

PUMP PRESSURE REGULATOR - A device that controls the speed of a pump in response to changes in pump discharge pressure.

TEMPERATURE REGULATOR - A direct operated device in which the energy to position valve closure member(s) is provided by changes of temperature energy of the controlled variable.

DIRECT OPERATED - A regulator that uses a temperature thermal system to directly provide the power to move the plug.

PILOT OPERATED - A regulator that uses a temperature thermal system to power a pilot mechanism which generates an amplified signal to position the plug of the regulator. The pilot may be internal or external.

PRESSURE TEMPERATURE - A dual function piloted regulator combining the control of both temperature and pressure. Control of pressure and temperature may be by a single pilot or multiple pilots. Pilot(s) may be internal or external or these functions in combination may be available.

DIAPHRAGM ACTUATED REGULATOR - A regulator utilizing a diaphragm as the position actuator.

ACCURACY OF REGULATION is the value of controlled variable (pressure, or differential pressure) expressed as a percentage of the set value (at minimum controllable flow) when with a constant supply pressure the flow through the regulator is increased from the minimum controllable flow to the rated capacity (also equal to 100% minus the offset (drop) %).

MINIMUM CONTROLLABLE FLOW is the lowest flow at which a steady regulated condition of the controlled variable can be maintained.

FLOW COEFFICIENT (Cv) is the regulator capacity in GPM of H₂O at 20 degrees C with one PSI pressure drop at full rated travel. Refer to ISA S75.01 and S75.02 for Testing Procedures and Sizing Equations.

DEAD BAND - The range through which the controlled variable can reverse direction without and observable regulator response.

REPEATABILITY - Ability to return to any defined point within stated limits of regulation within a specified tolerance.

DRIFT - A change in set point over an extended period of time.

REVERSE ACTION - A regulator that increases its output as the measured variable increases.

DIRECT ACTION - A regulator that decreases its output as the measured variable increases.

PACKLESS - A construction that does not employ a dynamic seal isolating internal fluid from ambient or atmosphere.

BALANCED - A regulator style featuring a pressure balanced plug. May be single or double seated.

UNBALANCED - A regulator where the plug closure number is not pressure balanced. Generally a single regulator.

DROOP - See accuracy of regulation.

FLOW VS. VELOCITY CHART

(Specific Gravity of 1)

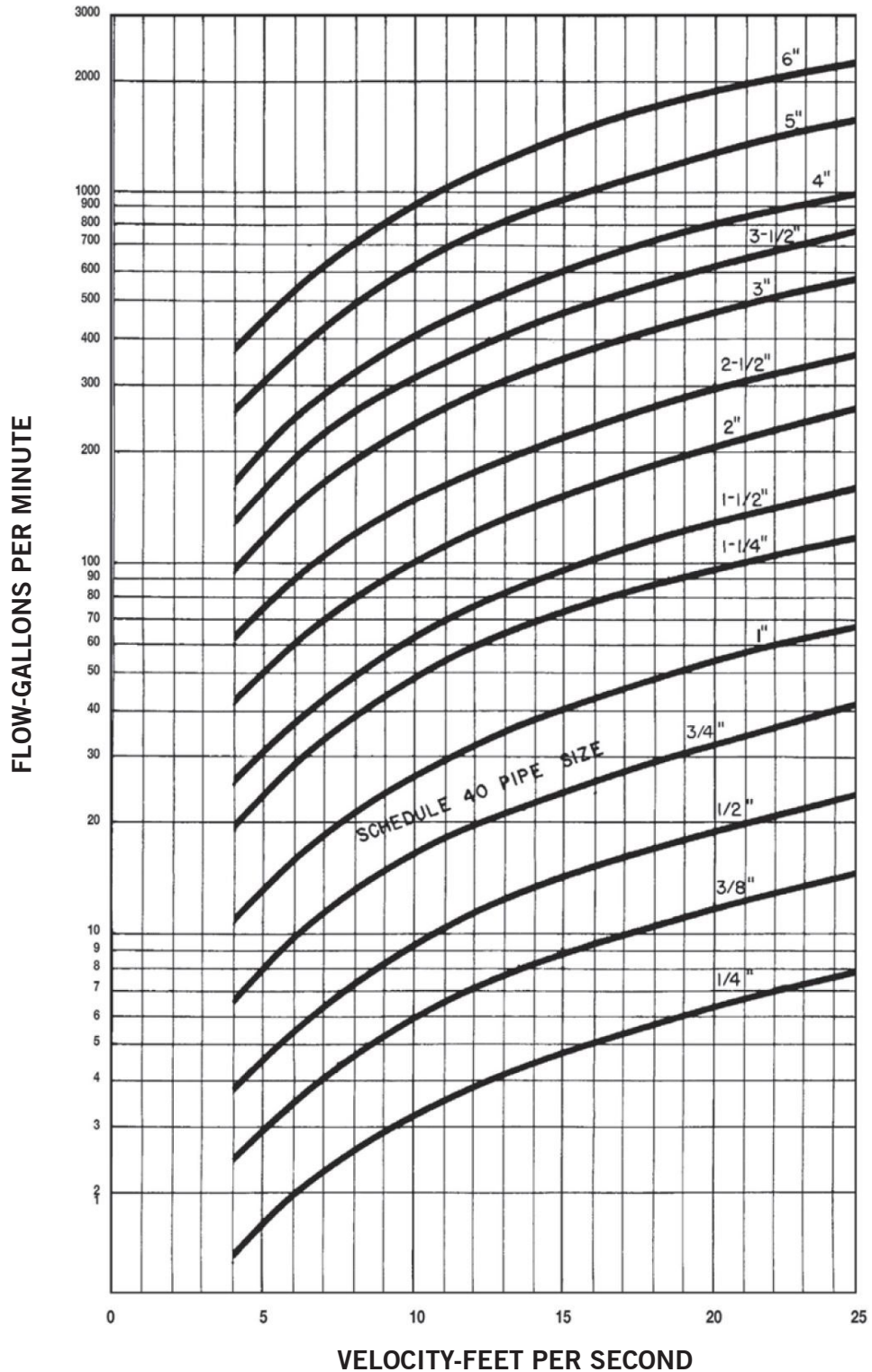

FLANGE STANDARDS

125 lb. CAST IRON

ANSI STANDARD B16.1

Pipe Size	1/2	3/4	1	1 1/4	1 1/2	2	2-1/2	3	3 1/2	4	5	6	8	10	12
Diameter of Flange	–	–	4 1/4	4 5/8	5	6	7	7 1/2	8 1/2	9	10	11	13 1/2	16	19
Thickness of Flange (min) ^a	–	–	7/16	1/2	9/16	5/8	1 1/16	3/1	13/16	15/16	15/16	1	1 1/8	13/16	1 1/1
Diameter of Bolt Circle	–	–	3 1/8	3 1/2	3 7/8	4 3/4	5 1/2	6	7	7 1/2	8 1/2	9 1/2	11-3/4	14 1/4	17
Number of Bolts	–	–	4	4	4	4	4	4	8	8	8	8	8	12	12
Diameter of Bolts	–	–	1/2	1/2	1/2	5/8	5/8	5/8	5/8	5/8	3/4	3/4	3/4	7/8	7/8

^a 125 lb. cast iron flanges have plain faces.

250 lb. CAST IRON

ANSI STANDARD B16.1

Pipe Size	1/2	3/4	1	1 1/4	1 1/2	2	2-1/2	3	3 1/2	4	5	6	8	10	12
Diameter of Flange	–	–	4 7/8	5 1/4	6 1/8	6 1/2	7 1/2	8 1/4	9	10	11	12-1/2	15	17 1/2	20 1/2
Thickness of Flange (min) ^b	–	–	11/16	3/4	13/16	7/8	1	1 1/8	1 3/16	1 1/4	1 3/8	1 7/16	1 5/8	1 7/8	2
Diameter of Raised Face	–	–	2 11/16	3 1/16	3 9/16	4 3/16	4 15/16	5 11/16	6 5/16	6 15/16	8 5/16	9 11/16	11 15/16	14 1/6	16 7/16
Diameter of Bolt Circle	–	–	3 1/2	3 7/8	4 1/2	5	5 7/8	6 5/8	7 1/4	7 1/8	9 1/4	10 5/8	13	15 1/4	17 3/4
Number of Bolts	–	–	4	4	4	8	8	8	8	8	8	12	12	16	16
Diameter of Bolts	–	–	5/8	5/8	3/4	5/8	3/4	3/4	3/4	3/4	3/4	3/4	7/8	1	1 1/8

^b 250 lb. cast iron flanges have a 1/16" raised face which is included in the flange thickness dimensions.

150 lb. BRONZE

ANSI STANDARD B16.24

Pipe Size	1/2	3/4	1	1 1/4	1 1/2	2	2-1/2	3	3 1/2	4	5	6	8	10	12
Diameter of Flange	3 1/2	3 7/8	4 1/4	4 5/8	5	6	7	7 1/2	8 1/2	9	10	11	13 1/2	16	19
Thickness of Flange (min) ^c	5/16	11/32	3/8	13/32	7/16	1/2	9/16	5/8	11/16	11/16	3/4	13/16	15/16	1	1 1/16
Diameter of Bolt Circle	2 3/8	2 3/4	3 1/8	3 1/2	3 7/8	4 3/4	5 1/2	6	7	7 1/2	8 1/2	9 1/2	11-3/4	14 1/4	17
Number of Bolts	4	4	4	4	4	4	4	4	8	8	8	8	8	12	12
Diameter of Bolts	1/2	1/2	1/2	1/2	1/2	5/8	5/8	5/8	5/8	5/8	3/4	3/4	3/4	7/8	7/8

^c 150 lb. bronze flanges have plain faces with two concentric gasket-retaining grooves between the port and the bolt holes.

300 lb. BRONZE

ANSI STANDARD B16.24

Pipe Size	1/2	3/4	1	1 1/4	1 1/2	2	2-1/2	3	3 1/2	4	5	6	8	10	12
Diameter of Flange	3 3/4	4 5/8	4 7/8	5 1/4	6 1/2	6 1/2	7 1/2	8 1/4	9	10	11	12-1/2	15	–	–
Thickness of Flange (min) ^d	1/2	17/32	19/32	5/8	11/16	3/4	13/16	29/32	31/32	1 1/16	1 1/8	1 3/16	1 3/8	–	–
Diameter of Bolt Circle	2 5/8	3 1/4	3 1/2	3 7/8	4 1/2	5	5 7/8	6 5/8	7 1/4	7 7/8	9 1/4	10 5/8	13	–	–
Number of Bolts	4	4	4	4	4	8	8	8	8	8	8	12	12	–	–
Diameter of Bolts	1/2	5/8	5/8	5/8	3/4	5/8	3/4	3/4	3/4	3/4	3/4	3/4	7/8	–	–

^d 300 lb. bronze flanges have plain faces with two concentric gasket-retaining grooves between the port and the bolt holes.

150 lb. STEEL

ANSI STANDARD B16.5

Pipe Size	1/2	3/4	1	1 1/4	1 1/2	2	2-1/2	3	3 1/2	4	5	6	8	10	12
Diameter of Flange	–	–	4	4 5/8	5	6	7	7 1/2	8 1/2	9	10	11	13 1/2	16	19
Thickness of Flange (min) ^e	–	–	7/16	1/2	9/16	5/8	11/16	3/4	13/16	15/16	15/16	1	1 1/8	1 3/16	1 1/4
Diameter of Raised Face	–	–	2	2-1/2	2 7/8	3 5/8	4 1/8	5	5 1/2	6 3/16	7 5/16	8 1/2	10 5/8	12 3/4	15
Diameter of Bolt Circle	–	–	3 1/8	3 1/2	3 7/8	4 3/4	5 1/2	6	7	7 1/2	8 1/2	9 1/2	11-3/4	14 1/4	17
Number of Bolts	–	–	4	4	4	4	4	4	8	8	8	8	12	12	12
Diameter of Bolts	–	–	1/2	1/2	1/2	5/8	5/8	5/8	5/8	5/8	3/4	3/4	3/4	7/8	7/8

^e 150 lb. steel flanges have a 1/16" raised face which is included in the flange thickness dimensions.

300 lb. STEEL

ANSI STANDARD B16.5

Pipe Size	1/2	3/4	1	1 1/4	1 1/2	2	2-1/2	3	3 1/2	4	5	6	8	10	12
Diameter of Flange	–	–	4 7/8	5 1/4	6 1/8	6 1/2	7 1/2	8 1/4	9	10	11	12-1/2	15	17 1/2	20 1/2
Thickness of Flange (min) ^f	–	–	11/16	3/4	13/16	7/8	1	1 1/8	1 3/16	1 1/4	1 3/8	1 7/16	1 5/8	1 7/8	2
Diameter of Raised Face	–	–	2	2-1/2	2 7/8	3 5/8	4 1/8	5	5 1/2	6 3/16	7 5/16	8 1/2	10 5/8	12 3/4	15
Diameter of Bolt Circle	–	–	3 1/2	3 7/8	4 1/2	5	5 7/8	6 5/8	7 1/4	7 7/8	9 1/4	10 5/8	13	15 1/4	17 3/4
Number of Bolts	–	–	4	4	4	8	8	8	8	8	8	12	12	16	16
Diameter of Bolts	–	–	5/8	5/8	3/4	5/8	3/4	3/4	3/4	3/4	3/4	3/4	7/8	1	1 1/8

^f 300 lb. steel flanges have a 1/16" raised face which is included in the flange thickness dimensions.

400 lb. STEEL

ANSI STANDARD B16.5

Pipe Size	1/2	3/4	1	1 1/4	1 1/2	2	2-1/2	3	3 1/2	4	5	6	8	10	12
Diameter of Flange	3 3/4	4 5/8	4 7/8	5 1/4	6 1/8	6 1/2	7 1/2	8 1/4	9	10	11	12-1/2	15	17 1/2	20 1/2
Thickness of Flange (min) ^g	9/16	5/8	11/16	13/16	7/8	1	1 1/8	1 1/4	1 3/8	1 3/8	1 1/2	1 5/8	1 7/8	2 1/8	2 1/4
Diameter of Raised Face	1/38	1 11/16	2	2-1/2	2 7/8	3 5/8	4 1/8	5	5 1/2	6 3/16	7 5/16	8 1/2	10 5/8	12 3/4	15
Diameter of Bolt Circle	2 5/8	3 1/4	3 1/2	3 7/8	4 1/2	5	5 7/8	6 5/8	7 1/4	7 7/8	9 1/4	10 5/8	13	15 1/4	17 3/4
Number of Bolts	4	4	4	4	4	8	8	8	8	8	8	12	12	16	16
Diameter of Bolts	1/2	5/8	5/8	5/8	3/4	5/8	3/4	3/4	7/8	7/8	7/8	7/8	1	1 1/8	1 1/4

^g 400 lb. steel flanges have a 1/4" raised face which is included in the flange thickness dimensions.

600 lb. STEEL

ANSI STANDARD B16.5

Pipe Size	1/2	3/4	1	1 1/4	1 1/2	2	2-1/2	3	3 1/2	4	5	6	8	10	12
Diameter of Flange	3 3/4	4 5/8	4 7/8	5 1/4	6 1/8	6 1/2	7 1/2	8 1/4	9	10 3/4	13	14	16 1/2	20	22
Thickness of Flange (min) ^h	9/16	5/8	11/16	13/16	7/8	1	1 1/8	1 1/4	1 3/8	1 1/2	1 3/4	1 7/8	2 3/16	2-1/2	2 5/8
Diameter of Raised Face	1 3/8	1 11/16	2	2-1/2	2 7/8	3 5/8	4 1/8	5	5 1/2	6 3/16	7 5/16	8 1/2	10 5/8	12 3/4	15
Diameter of Bolt Circle	2 5/8	3 1/4	3 1/2	3 7/8	4 1/2	5	5 7/8	6 5/8	7 1/4	8 1/2	10 1/2	11 1/2	13 3/4	17	19 1/4
Number of Bolts	4	4	4	4	4	8	8	8	8	8	8	12	12	16	20
Diameter of Bolts	1/2	5/8	5/8	5/8	3/4	5/8	3/4	3/4	7/8	7/8	1	1	1 1/8	1 1/4	1 1/4

^h 600 lb. steel flanges have a 1/4" raised face which is included in the flange thickness dimensions

CONVERSION TABLES

LIQUID WEIGHTS and MEASURES		
To Convert	To	Multiply By
Gallons	Liters	3.7853
Gallons	Cu. Inches	231
Gallons	Cu. Feet Cu.	0.1337
Gallons	Meters Lbs. of	0.00379
Gallons	Water	8.339
Liters	Gallons	0.26418
Liters	Cu. Inches	61.025
Liters	Cu. Feet	0.0353
Liters	Cu. Meters	0.001
Liters	Lbs. of Water	2.202
Cu. Inches	Gallons	0.00433
Cu. Inches	Liters	0.01639
Cu. Inches	Cu. Feet	0.00058
Cu. Inches	Cu. Meters	0.000016
Cu. Inches	Lbs. of Water	0.0362
Cu. Feet	Gallons	7.48052
Cu. Feet	Liters	28.316
Cu. Feet	Cu. Inches	1728
Cu. Feet	Cu. Meters	0.0283
Cu. Feet	Lbs. of Water	0.0283
Cu. Meters	Gallons	264.17
Cu. Meters	Liters	999.972
Cu. Meters	Cu. Inches	61023.74
Cu. Meters	Cu. Feet	35.3145
Cu. Meters	Lbs. of Water	2202.61
Lbs. of Water	Gallons	0.11992
Lbs. of Water	Liters	0.45419
Lbs. of Water	Cu. Inches	27.643
Lbs. of Water	Cu. Feet	0.01603
Lbs. of Water	Cu. Meters	0.000454
LINEAL MEASURES		
Inches	mm	25.4
Inches	cm	2.54
Inches	Meters	0.0254
Feet	cm	30.48
Feet	Meters	0.3048
mm	Inches	0.03937
mm	Feet	0.00328
cm	Inches	0.3937
cm	Feet	0.03281
Meters	Feet	3.28
AREA		
Sq. Inches	Sq. Feet	0.006944
Sq. Inches	Sq. cm	6.4516
Sq. Feet	Sq. Inches	144
Sq. Feet	Sq. cm	929.03
Sq. Feet	Sq. Meters	0.0929
Sq. cm	Sq. Inches	0.155
Sq. cm	Sq. Feet	0.00108
Sq. cm	Sq. Meters	0.0001
Sq. Meter	Sq. Inches	1550
Sq. Meter	Sq. Feet	10.76

LIQUID WEIGHTS and MEASURES					
To Convert	To	Multiply By	To Convert	To	Multiply By
Lbs. per Sq. In.	Lbs. per Sq. Ft.	144	Ins. of Mercury	Lbs. per Sq. In.	0.491154
Lbs. per Sq. In.	Atmospheres	0.06805	Ins. of Mercury	Lbs. per Sq. Ft.	70.7262
Lbs. per Sq. In.	Ins. of Water	27.728	Ins. of Mercury	Atmospheres	0.033421
Lbs. per Sq. In.	Ft. of Water	2.3106	Ins. of Mercury	Ins. of Water	13.6185
Lbs. per Sq. In.	Ins. of Mercury	2.03602	Ins. of Mercury	Ft. of Water	1.1349
Lbs. per Sq. In.	mm of Mercury	51.715	Ins. of Mercury	mm of Mercury	25.40005
Lbs. per Sq. In.	Bar	0.06895	Ins. of Mercury	Bar	0.033864
Lbs. per Sq. In.	kg per Sq. cm	0.070307	Ins. of Mercury	kg per Sq. cm	0.03453
Lbs. per Sq. In.	kg per Sq. M	703.070	Ins. of Mercury	kg per Sq. M	345.316
Lbs. per Sq. Ft.	Lbs. per Sq. In.	0.0069445	mm of Mercury	Lbs. per Sq. In.	0.019337
Lbs. per Sq. Ft.	Atmospheres	0.000473	mm of Mercury	Lbs. per Sq. Ft.	2.7845
Lbs. per Sq. Ft.	Ins. of Water	0.1926	mm of Mercury	Atmospheres	0.001316
Lbs. per Sq. Ft.	Ft. of Water	0.01605	mm of Mercury	Ins. of Water	0.53616
Lbs. per Sq. Ft.	Ins. of Mercury	0.014139	mm of Mercury	Ft. of Water	0.04468
Lbs. per Sq. Ft.	mm of Mercury	0.35913	mm of Mercury	Ins. of Mercury	0.03937
Lbs. per Sq. Ft.	Bar	0.000479	mm of Mercury	Bar	0.00133
Lbs. per Sq. Ft.	kg per Sq. cm	0.000488	mm of Mercury	kg per Sq. cm	0.00136
Lbs. per Sq. Ft.	kg per Sq. M	4.88241	mm of Mercury	kg per Sq. M	13.59509
Atmospheres	Lbs. per Sq. In.	14.696	kg per Sq. cm	Lbs. per Sq. In.	14.2233
Atmospheres	Lbs. per Sq. Ft.	2116.22	kg per Sq. cm	Lbs. per Sq. Ft.	2048.155
Atmospheres	Ins. of Water	407.484	kg per Sq. cm	Atmospheres	0.96784
Atmospheres	Ft. of Water	33.957	kg per Sq. cm	Ins. of Water	394.38
Atmospheres	Ins. of Mercury	29.921	kg per Sq. cm	Ft. of Water	32.865
Atmospheres	mm of Mercury	760	kg per Sq. cm	Ins. of Mercury	28.959
Atmospheres	Bar	1.01325	kg per Sq. cm	mm of Mercury	735.559
Atmospheres	kg per Sq. cm	1.0332	kg per Sq. cm	Bar	0.98067
Atmospheres	kg per Sq. M	10332.27	kg per Sq. cm	kg per Sq. M	10000
Ins. of Water	Lbs. per Sq. In.	0.03609	<p>Note: All weights and measures of water are based on temperature of 60°F.</p> <p>Note: Temperature of Water and Mercury is 68°F and 32°F respectively.</p> <p style="text-align: center;">TEMPERATURE</p> <p style="text-align: center;">To convert Fahrenheit to Celsius: $\frac{^{\circ}\text{F} - 32}{1.8}$</p> <p style="text-align: center;">To convert Celsius to Fahrenheit: $(1.8 \times ^{\circ}\text{C}) + 32$</p> <p style="text-align: center;">VELOCITY</p> <p style="text-align: center;">1 Ft per Sec. = 0.3048 M Per Sec.</p> <p style="text-align: center;">1 M per Sec. = 3.2808 Ft. per Sec.</p>		
Ins. of Water	Lbs. per Sq. Ft.	5.1972			
Ins. of Water	Atmospheres	0.002454			
Ins. of Water	Ft. of Water	0.08333			
Ins. of Water	Ins. of Mercury	0.07343			
Ins. of Water	mm of Mercury	1.8651			
Ins. of Water	Bar	0.00249			
Ins. of Water	kg per Sq. cm	0.00253			
Ins. of Water	kg per Sq. M	25.375			
Ft. of Water	Lbs. per Sq. In.	0.432781			
Ft. of Water	Lbs. per Sq. Ft.	63.3205			
Ft. of Water	Atmospheres	0.029449			
Ft. of Water	Ins. of Water	12			
Ft. of Water	Ins. of Mercury	0.88115			
Ft. of Water	mm of Mercury	22.3813			
Ft. of Water	Bar	0.029839			
Ft. of Water	kg per Sq. cm	0.03043			
Ft. of Water	kg per Sq. M	304.275			

PRESSURE TO VACUUM PROPERTIES OF WATER

Gage Indicated		ABSOLUTE PRESSURE		
PSIG	Inches of Hg	PSIA	Inches of Hg	Torrilli
-14.70000	29.92000	0.0	0.0	0.0
-14.69998	29.91996	0.00002	0.00004	0.001
-14.69996	29.91992	0.00004	0.00008	0.002
-14.69994	29.91988	0.00006	0.00012	0.003
-14.69992	29.91984	0.00008	0.00016	0.004
-14.69990	29.91980	0.00010	0.00020	0.005
-14.69981	29.91961	0.00019	0.00039	0.010
-14.69961	29.91921	0.00039	0.00079	0.020
-14.69942	29.91882	0.00058	0.00118	0.030
-14.69923	29.91843	0.00077	0.00157	0.040
-14.69903	29.91803	0.00097	0.00197	0.050
-14.69806	29.91606	0.00194	0.00394	0.100
-14.69613	29.91212	0.00387	0.00788	0.200
-14.69449	29.90818	0.00551	0.01182	0.300
-14.69226	29.90424	0.00774	0.01576	0.400
-14.69032	29.90030	0.00968	0.01970	0.500
-14.68066	29.88063	0.01934	0.03937	1.000
-14.66698	29.84126	0.03302	0.07874	2.000
-14.64197	29.80189	0.05803	0.11811	3.000
-14.62262	29.76252	0.07738	0.15748	4.000
-14.60329	29.72315	0.09671	0.19685	5.000
-14.50658	29.52630	0.19342	0.39370	10.000
-14.40980	29.32940	0.29020	0.59060	15.000
-14.31320	29.13260	0.38680	0.78740	20.000
-14.21840	28.93570	0.48160	0.98430	25.000
-14.20870	28.920	0.49130	1.000	25.400
-14.11970	28.740	0.58030	1.181	30.000
-13.75700	28.000	0.94330	1.920	48.770
-12.28300	25.000	2.4170w0	4.920	124.970
-10.31800	21.000	4.38200	8.920	226.570
-8.84400	18.000	5.85600	11.920	302.770
-7.37000	15.000	7.320	14.920	378.970
-5.89600	12.000	8.804	17.920	455.770
-4.91300	10.000	9.787	19.920	505.970
-3.93000	8.000	10.770	21.920	556.770
-2.94800	6.000	11.752	23.920	607.570
-1.96500	4.000	12.735	25.920	658.370
-0.98300	2.000	13.732	27.920	709.170
-0.49100	1.000	14.209	28.920	733.570
-0.24600	0.500	14.454	29.420	747.270
ATMOSPHERIC				
0.0	0.0	14.700	29.920	760.000
+ 0.30		15.000	30.540	775.720
+ 1.00		15.700	31.970	811.910
+ 2.00		16.700	34.000	863.630
+ 10.00		24.700	34.000	277.35

Water Temp.	Saturation Pressure	Weight	Weight Density	Specific Volume
Deg. F	PSIA	lbs/Gallon	lbs/Cu.Ft.	Cu.Ft./lb
32	0.0886	8.844	62.414	0.016022
40	0.1216	8.345	62.426	0.016019
50	0.1780	8.343	62.410	0.016023
60	0.2561	8.338	62.371	0.016033
70	0.3629	8.329	62.305	0.016050
80	0.5068	8.318	62.220	0.016072
90	0.6981	8.304	62.116	0.016099
100	0.9492	8.288	61.996	0.016130
110	1.2750	8.270	61.862	0.016165
120	1.6927	8.250	61.713	0.016204
130	2.2230	8.228	61.550	0.016247
140	2.8892	8.205	61.376	0.016293
150	3.7184	8.180	61.188	0.016343
160	4.7414	8.154	60.994	0.016395
170	5.9926	8.126	60.787	0.016451
180	7.5110	8.097	60.569	0.016510
190	9.340	8.067	60.343	0.016572
200	11.526	8.035	60.107	0.016637
210	14.123	8.002	59.862	0.016705
212	14.696	7.996	59.812	0.016719
220	17.186	7.969	59.613	0.016775
240	24.968	7.898	59.081	0.016926
260	35.427	7.823	58.517	0.017089
280	49.200	7.743	57.924	0.017264
300	67.005	7.661	57.307	0.01745
350	134.604	7.431	55.586	0.01799
400	247.259	7.172	53.648	0.01864
450	422.55	6.880	51.467	0.01943
500	680.86	6.543	48.948	0.02043
550	1045.43	6.143	45.956	0.02176
600	1543.2	5.655	42.301	0.02364
650	2208.4	4.999	37.397	0.02674
700	3094.3	3.651	27.307	0.03662

NOTE:

Weight of water per gallon is based on 7.48052 gallons per cubic foot.

Specific gravity of water @ 60°F = 1.00

PIPE DATA TABLES

Pipe Size (in.)	Outside Diameter (in.)	Weight Class	Carbon Steel Sched.	Stainless Steel Sched.	Wall Thickness (in.)	Inside Diameter (in.)	Circum. (Ext.) (in.)	Circum. (Int.) (in.)	Flow Area (sq. in.)	Weight of Pipe (lbs/Ft.)	Weight of Water (lbs/Ft.)	Gallons of Water per Ft.	Section Modulus	Pipe Size (in.)
1/8	.405	—	—	10S	.049	.307	1.27	.96	.074	.19	.032	.004	.00437	1/8
		STD	40	40S	.068	.269		.85	.057	.24	.025	.003	.00523	
		XS	80	80S	.095	.215		.68	.036	.31	.016	.002	.00602	
1/4	.540	—	—	10S	.065	.410	1.70	1.29	.132	.33	.057	.007	.01032	1/4
		STD	40	40S	.088	.364		1.14	.104	.42	.045	.005	.01227	
		XS	80	80S	.119	.302		.95	.072	.54	.031	.004	.01395	
3/8	.675	—	—	10S	.065	.545	2.12	1.71	.233	.42	.101	.012	.01736	3/8
		STD	40	40S	.091	.493		1.55	.191	.57	.083	.010	.0216	
		XS	80	80S	.126	.423		1.33	.141	.74	.061	.007	.0255	
1/2	.840	—	—	5S	.065	.710	2.64	2.23	.396	.54	.172	.021	.0285	1/2
		—	—	10S	.083	.674		2.12	.357	.67	.155	.019	.0341	
		STD	40	40S	.109	.622		1.95	.304	.85	.132	.016	.0407	
		XS	80	80S	.147	.546		1.72	.234	1.09	.102	.012	.0478	
		—	160	—	.187	.466		1.46	.171	1.31	.074	.009	.0527	
XXS	—	—	.294	.252	.79	.050	1.71	.022	.003	.0577				
3/4	1.050	—	—	5S	.065	.920	3.30	2.89	.665	.69	.288	.035	.0467	3/4
		—	—	10S	.083	.884		2.78	.614	.86	.266	.032	.0566	
		STD	40	40S	.113	.824		2.59	.533	1.13	.231	.028	.0706	
		XS	80	80S	.154	.742		2.33	.433	1.47	.188	.022	.0853	
		—	160	—	.219	.612		1.92	.296	1.94	.128	.015	.1004	
XXS	—	—	.308	.434	1.36	.148	2.44	.064	.008	.1103				
1	1.315	—	—	5S	.065	1.185	4.13	3.72	1.103	.87	.478	.057	.0760	1
		—	—	10S	.109	1.097		3.45	.945	1.40	.409	.049	.1151	
		STD	40	40S	.133	1.049		3.30	.864	1.68	.375	.045	.1328	
		XS	80	80S	.179	.957		3.01	.719	2.17	.312	.037	.1606	
		—	160	—	.250	.815		2.56	.522	2.84	.230	.027	.1903	
XXS	—	—	.358	.599	1.88	.282	3.66	.122	.015	.2136				
1 ^{1/4}	1.660	—	—	5S	.065	1.530	5.22	4.81	1.839	1.11	.797	.096	.1250	1 ^{1/4}
		—	—	10S	.109	1.442		4.53	1.633	1.81	.708	.085	.1934	
		STD	40	40S	.140	1.380		4.34	1.495	2.27	.649	.078	.2346	
		XS	80	80S	.191	1.278		4.02	1.283	3.00	.555	.067	.2913	
		—	160	—	.250	1.160		3.64	1.057	3.76	.458	.055	.3421	
XXS	—	—	.382	.896	2.81	.630	5.21	.273	.033	.4110				
1 ^{1/2}	1.900	—	—	5S	.065	1.770	97	5.56	2.461	1.28	1.066	.128	.1662	1 ^{1/2}
		—	—	10S	.109	1.682		5.28	2.222	2.09	.963	.115	.2598	
		STD	40	40S	.145	1.610		5.06	2.036	2.72	.882	.106	.3262	
		XS	80	80S	.200	1.500		4.71	1.767	3.63	.765	.092	.4118	
		—	160	—	.281	1.338		4.20	1.406	4.86	.608	.073	.5078	
10(S)	—	—	.400	1.100	3.46	.950	6.41	.420	.049	.5977				
2	2.375	—	—	5S	.065	2.245	7.46	7.05	3.958	1.61	1.72	.206	.2652	2
		—	—	10S	.109	2.157		6.78	3.654	2.64	1.58	.190	.4204	
		STD	40	40S	.154	2.067		6.49	3.355	3.65	1.45	.174	.5606	
		XS	80	80S	.218	1.939		6.09	2.953	5.02	1.28	.153	.7309	
		—	160	—	.344	1.687		5.30	2.241	7.46	.97	.116	.9790	
XXS	—	—	.436	1.503	4.72	1.774	9.03	.77	.092	1.1040				
2 ^{1/2}	2.875	—	—	5S	.083	2.709	9.03	8.51	5.764	2.48	2.50	.299	.4939	2 ^{1/2}
		—	—	10S	.120	2.635		8.28	5.453	3.53	2.36	.283	.6868	
		STD	40	40S	.203	2.469		7.76	4.788	5.79	2.07	.249	1.064	
		XS	80	80S	.276	2.323		7.30	4.238	7.66	1.87	.220	1.339	
		—	160	—	.375	2.125		6.68	3.546	10.01	1.54	.184	1.638	
XXS	—	—	.552	1.771	5.56	2.464	13.69	1.07	.128	1.997				

PIPE DATA TABLES CONT'D.

Pipe Size (in.)	Outside Diameter (in.)	Weight Class	Carbon Steel Sched.	Stainless Steel Sched.	Wall Thickness (in.)	Inside Diameter (in.)	Circum. (Ext.) (in.)	Circum (Int.) (in.)	Flow Area (sq. in.)	Weight of Pipe (lbs/Ft.)	Weight of Water (lbs/Ft.)	Gallons of Water per Ft.	Section Modulus	Pipe Size (in.)
3	3.500	-	-	5S	.083	3.334	11.00	10.47	8.730	3.03	3.78	.454	.744	3
		-	-	10S	.120	3.260		10.24	8.347	4.33	3.62	.434	1.041	
		STD	40	40S	.216	3.068		9.64	7.393	7.58	3.20	.384	1.724	
		XS	80	80S	.300	2.900		9.11	6.605	10.25	2.86	.343	2.225	
		-	160	-	.438	2.624		8.24	5.408	14.32	2.35	.281	2.876	
		XXS	-	-	.600	2.300		7.23	4.155	18.58	1.80	.216	3.424	
4	4.500	-	-	5S	.083	4.334	14.14	13.62	14.75	3.92	6.39	.766	1.249	4
		-	-	10S	.120	4.260		13.38	14.25	5.61	6.18	.740	1.761	
		STD	40	40S	.237	4.026		12.65	12.73	10.79	5.50	.661	3.214	
		XS	80	80S	.337	3.826		12.02	11.50	14.98	4.98	.597	4.271	
		-	120	-	.438	3.624		11.39	10.31	19.00	4.47	.536	5.178	
		XXS	-	-	.531	3.438		10.80	9.28	22.51	4.02	.482	5.898	
5	5.563	-	-	5S	.109	5.345	17.48	16.79	22.44	6.36	9.72	1.17	2.498	5
		-	-	10S	.134	5.295		16.63	22.02	7.77	9.54	1.14	3.029	
		STD	40	40S	.258	5.047		15.86	20.01	14.62	8.67	1.04	5.451	
		XS	80	80S	.375	4.813		15.12	18.19	20.78	7.88	.945	7.431	
		-	120	-	.500	4.563		14.34	16.35	27.04	7.09	.849	9.250	
		XXS	-	-	.625	4.313		13.55	14.61	32.96	6.33	.759	10.796	
6	6.625	-	-	5S	.109	6.407	20.81	20.13	32.24	7.60	13.97	1.68	3.576	6
		-	-	10S	.134	6.357		19.97	31.74	9.29	13.75	1.65	4.346	
		STD	40	40S	.280	6.065		19.05	28.89	18.97	12.51	1.50	8.496	
		XS	80	80S	.432	5.761		18.10	26.07	28.57	11.29	1.35	12.22	
		-	120	-	.562	5.501		17.28	23.77	36.39	10.30	1.24	14.98	
		XXS	-	-	.719	5.187		16.30	21.15	45.35	9.16	1.10	17.81	
8	8.625	-	-	5S	.109	8.407	27.10	26.41	55.51	9.93	24.06	2.88	6.131	8
		-	-	10S	.148	8.329		26.17	54.48	13.40	23.61	2.83	8.212	
		-	20	-	.250	8.125		25.53	51.85	22.36	22.47	2.69	13.39	
		-	30	-	.277	8.071		25.36	51.16	24.70	22.17	2.66	14.69	
		STD	40	40S	.322	7.981		25.07	50.03	28.55	21.70	2.60	16.81	
		-	60	-	.406	7.813		24.55	47.94	35.64	20.77	2.49	20.58	
		XS	80	80S	.500	7.625		23.95	45.66	43.39	19.78	2.37	24.51	
		-	100	-	.594	7.437		23.36	43.46	50.95	18.83	2.26	28.14	
		-	120	-	.719	7.187		22.58	40.59	60.71	17.59	2.11	32.58	
		-	140	-	.812	7.001		21.99	38.50	67.76	16.68	2.00	35.65	
		XXS	-	-	.875	6.875		21.60	37.12	72.42	16.10	1.93	37.56	
		-	160	-	.906	6.813		21.40	36.46	74.69	15.80	1.89	38.48	
10	10.750	-	-	5S	.134	10.482	33.77	32.93	86.29	15.19	37.39	4.48	11.71	10
		-	-	10S	.165	10.420		32.74	85.28	18.65	36.95	4.43	14.30	
		-	20	-	.250	10.250		32.20	82.52	28.04	35.76	4.29	21.15	
		-	30	-	.307	10.136		31.84	80.69	34.24	34.96	4.19	25.57	
		STD	40	40S	.365	10.020		31.48	78.86	40.48	34.20	4.10	29.90	
		XS	60	80S	.500	9.750		30.63	74.66	54.74	32.35	3.88	39.43	
		-	80	-	.594	9.562		30.04	71.84	64.43	31.13	3.73	45.54	
		-	100	-	.719	9.312		29.25	68.13	77.03	29.53	3.54	53.22	
		-	120	-	.844	9.062		28.47	64.53	89.29	27.96	3.35	60.32	
		XXS	140	-	1.000	8.750		27.49	60.13	104.13	26.06	3.12	68.43	
		-	160	-	1.125	8.500		26.70	56.75	115.64	24.59	2.95	74.29	

PIPE DATA TABLES CONT'D.

Pipe Size (in.)	Outside Diameter (in.)	Weight Class	Carbon Steel Sched.	Stainless Steel Sched.	Wall Thickness (in.)	Inside Diameter (in.)	Circum. (Ext.) (in.)	Circum. (Int.) (in.)	Flow Area (sq. in.)	Weight of Pipe (lbs/Ft.)	Weight of Water (lbs/Ft.)	Gallons of Water per Ft.	Section Modulus	Pipe Size (in.)
12	12.750	-	-	5S	.156	12.438	40.06	39.08	121.50	20.98	52.65	6.31	19.2	12
		-	-	10S	.180	12.390		38.92	120.57	24.17	52.25	6.26	22.0	
		-	20	-	.250	12.250		38.48	117.86	33.38	51.07	6.12	30.2	
		-	30	-	.330	12.090		37.98	114.80	43.77	49.74	5.96	39.0	
		STD	-	40S	.375	12.000		37.70	113.10	49.56	49.00	5.88	43.8	
		-	40	-	.406	11.938		37.50	111.93	53.52	48.50	5.81	47.1	
		XS	-	80S	.500	11.750		36.91	108.43	65.42	46.92	5.63	56.7	
		-	60	-	.562	11.626		36.52	106.16	73.15	46.00	5.51	62.8	
		-	80	-	.688	11.374		35.73	101.64	88.63	44.04	5.28	74.6	
		-	100	-	.844	11.062		34.75	96.14	107.32	41.66	4.99	88.1	
		XXS	120	-	1.000	10.750		33.77	90.76	125.49	39.33	4.71	100.7	
		-	140	-	1.125	10.500		32.99	86.59	139.67	37.52	4.50	109.9	
-	160	-	1.312	10.126	31.81	80.53	160.27	34.89	4.18	122.6				
14	14.000	-	-	5S	.156	13.688	43.98	43.00	147.15	23.07	63.77	7.64	23.2	14
		-	-	10S	.188	13.624		42.80	145.78	27.73	63.17	7.57	27.8	
		-	10	-	.250	13.500		42.41	143.14	36.71	62.03	7.44	36.6	
		-	20	-	.312	13.376		42.02	140.52	45.61	60.89	7.30	45.0	
		STD	30	-	.375	13.250		41.63	137.88	54.57	59.75	7.16	53.2	
		-	40	-	.438	13.124		41.23	135.28	63.44	58.64	7.03	61.3	
		XS	-	-	.500	13.000		40.84	132.73	72.09	57.46	6.90	69.1	
		-	60	-	.594	12.812		40.25	128.96	85.05	55.86	6.70	80.3	
		-	80	-	.750	12.500		39.27	122.72	106.13	53.18	6.37	98.2	
		-	100	-	.938	12.124		38.09	115.49	130.85	50.04	6.00	117.8	
		-	120	-	1.094	11.812		37.11	109.62	150.79	47.45	5.69	132.8	
		-	140	-	1.250	11.500		36.13	103.87	170.28	45.01	5.40	146.8	
-	160	-	1.406	11.188	35.15	98.31	189.11	42.60	5.11	159.6				
16	16.000	-	-	5S	.165	15.670	50.27	49.23	192.85	27.90	83.57	10.02	32.2	16
		-	-	10S	.188	15.624		49.08	191.72	31.75	83.08	9.96	36.5	
		-	10	-	.250	15.500		48.69	188.69	42.05	81.74	9.80	48.0	
		-	20	-	.312	15.376		48.31	185.69	52.27	80.50	9.65	59.2	
		STD	30	-	.375	15.250		47.91	182.65	62.58	79.12	9.49	70.3	
		XS	40	-	.500	15.000		47.12	176.72	82.77	76.58	9.18	91.5	
		-	60	-	.656	14.688		46.14	169.44	107.50	73.42	8.80	116.6	
		-	80	-	.844	14.312		44.96	160.92	136.61	69.73	8.36	144.5	
		-	100	-	1.031	13.938		43.79	152.58	164.82	66.12	7.93	170.5	
		-	120	-	1.219	13.562		42.61	144.50	192.43	62.62	7.50	194.5	
		-	140	-	1.438	13.124		41.23	135.28	233.64	58.64	7.03	220.0	
		-	160	-	1.594	12.812		40.26	128.96	245.25	55.83	6.70	236.7	
18	18.000	-	-	5S	.165	17.67	56.55	55.51	245.22	31.43	106.26	12.74	40.8	18
		-	-	10S	.188	17.62		55.37	243.95	35.76	105.71	12.67	46.4	
		-	10	-	.250	17.50		54.98	240.53	47.39	104.21	12.49	61.1	
		-	20	-	.312	17.38		54.59	237.13	58.94	102.77	12.32	75.5	
		STD	-	-	.375	17.25		54.19	233.71	70.59	101.18	12.14	89.6	
		-	30	-	.438	17.12		53.80	230.30	82.15	99.84	11.96	103.4	
		XS	-	-	.500	17.00		53.41	226.98	93.45	98.27	11.79	117.0	
		-	40	-	.562	16.88		53.02	223.68	104.87	96.93	11.62	130.1	
		-	60	-	.750	16.50		51.84	213.83	138.17	92.57	11.11	168.3	
		-	80	-	.938	16.12		50.66	204.24	170.92	88.50	10.61	203.8	
		-	100	-	1.156	15.69		49.29	193.30	207.96	83.76	10.04	242.3	
		-	120	-	1.375	15.25		47.91	182.66	244.14	79.07	9.49	277.6	
-	140	-	1.562	14.88	46.73	173.80	274.22	75.32	9.03	305.5				
-	160	-	1.781	14.44	45.36	163.72	308.50	70.88	8.50	335.6				

PIPE DATA TABLES CONT'D.

Pipe Size (in.)	Outside Diameter (in.)	Weight Class	Carbon Steel Sched.	Stainless Steel Sched.	Wall Thickness (in.)	Inside Diameter (in.)	Circum. (Ext.) (in.)	Circum (Int.) (in.)	Flow Area (sq. in.)	Weight of Pipe (lbs/Ft.)	Weight of Water (lbs/Ft.)	Gallons of Water per Ft.	Section Modulus	Pipe Size (in.)
20	20.00	-	-	5S	.188	19.62	62.83	61.65	302.46	39.78	131.06	15.71	57.4	20
		-	-	10S	.218	19.56		61.46	300.61	46.06	130.27	15.62	66.3	
		-	10	-	.250	19.50		61.26	298.65	52.73	129.42	15.51	75.6	
		-	20	-	.375	19.25		60.48	290.04	78.60	125.67	15.12	111.3	
		STD	30	-	.500	19.00		59.69	283.53	104.13	122.87	14.73	145.7	
		XS	40	-	.594	18.81		59.10	278.00	123.11	120.46	14.44	170.4	
		-	60	-	.812	18.38		57.73	265.21	166.40	114.92	13.78	225.7	
		-	80	-	1.031	17.94		56.35	252.72	208.87	109.51	13.13	277.1	
		-	100	-	1.281	17.44		54.78	238.83	256.10	103.39	12.41	331.5	
		-	120	-	1.500	17.00		53.41	226.98	296.37	98.35	11.79	375.5	
		-	140	-	1.750	16.50		51.84	213.82	341.09	92.66	11.11	421.7	
		-	160	-	1.969	16.06		50.46	202.67	379.17	87.74	10.53	458.5	
22	22.00	-	-	5S	.188	21.62	69.12	67.93	367.25	43.80	159.14	19.08	69.7	22
		-	-	10S	.218	21.56		67.75	365.21	50.71	158.26	18.97	80.4	
		-	10	-	.250	21.50		67.54	363.05	58.07	157.32	18.86	91.8	
		STD	20	-	.375	21.25		66.76	354.66	86.61	153.68	18.42	135.4	
		XS	30	-	.500	21.00		65.97	346.36	114.81	150.09	17.99	171.5	
		-	60	-	.875	20.25		63.62	322.06	197.41	139.56	16.73	295.0	
		-	80	-	1.125	19.75		62.05	306.35	250.81	132.76	15.91	366.4	
		-	100	-	1.375	19.25		60.48	291.04	302.88	126.12	15.12	432.6	
		-	120	-	1.625	18.75		58.90	276.12	353.61	119.65	14.34	493.8	
		-	140	-	1.875	18.25		57.33	261.59	403.00	113.36	13.59	550.3	
		-	160	-	2.125	17.75		55.76	247.45	451.06	107.23	12.85	602.4	
		24	24.00	-	-	5S		.218	23.56	75.40	74.03	436.10	55	
-	10			10S	.250	23.50	73.83	433.74	63		187.95	22.53	109.6	
STD	20			-	.375	23.25	73.04	424.56	95		183.95	22.05	161.9	
XS	-			-	.500	23.00	72.26	415.48	125		179.87	21.58	212.5	
-	30			-	.562	22.88	71.86	411.00	141		178.09	21.35	237.0	
-	40			-	.688	22.62	71.08	402.07	171		174.23	20.88	285.1	
-	60			-	.969	22.06	69.31	382.35	238		165.52	19.86	387.7	
-	80			-	1.219	21.56	67.74	365.22	297		158.26	18.97	472.8	
-	100			-	1.531	20.94	65.78	344.32	367		149.06	17.89	570.8	
-	120			-	1.812	20.38	64.01	326.08	430		141.17	16.94	652.1	
-	140			-	2.062	19.88	62.44	310.28	483		134.45	16.12	718.9	
-	160			-	2.344	19.31	60.67	292.98	542		126.84	15.22	787.9	
30	30.00	-	-	5S	.250	29.50	94.25	92.68	683.49	79	296.18	35.51	172.3	30
		-	10	10S	.312	29.38		92.29	677.71	99	293.70	35.21	213.8	
		STD	-	-	.375	29.25		91.89	671.96	119	291.18	34.91	255.3	
		XS	20	-	.500	29.00		91.11	660.52	158	286.22	34.31	336.1	
		-	30	-	.625	28.75		90.32	649.18	196	281.31	33.72	414.9	

PRESSURE TEMPERATURE LIMITS

Body Material and End Connection Selection

BASED ON: ANSI B16.1-1989 (Cast Iron) B16.24-1991 (Cast Bronze) B16.5-1996 (All Steels)

Enter selection table at the service temperature and read down the column. Obtain a figure for maximum allowable pressure which equals or exceeds the inlet pressure in the system. The materials are ranked in the order of their relative cost.

It is wise in most cases to make several tentative selections for body material and end connection to determine which is most economical. For instance, it may be advantageous to go to a higher body rating than to select a stronger alloy.

See product design limitations prior to final selection. Regular type (not bold) indicates recommended temperatures for each

Bold type areas indicate temperatures permitted by ANSI B16.5-1996, but NOT recommended. material.

- 2 = CLASS B CAST IRON
- 6 = GRADE WC1 (0.50% MOLY)
- 4 = GRADE C5 (5.50% CHROME)
- 22 = CAST BRONZE
- 8 = GRADE WC6 (1.25% CHROME)
- 9 = GRADE CF8 (304 SST)
- 3 = GRADE WCB CARBON STEEL
- 7 = GRADE WC9 (2.25% CHROME)
- 5 = GRADE CF8M (316 SST)

MAXIMUM PRESSURE (PSIG) AT SERVICE TEMPERATURE (°F) - (NON-SHOCK)

END CONNECTIONS	BODY MAT'L CODE	ASTM SPEC.	TEMPERATURE (°F)																			
			100	150	200	250	300	350	400	450	500	550	600	650	700	750	800	850	900	950	1000	1050
125# FLANGES THREADS 2"-12	2	AL26	200	200	190	175	165	150	140	125												
	22	B62	200	200	190	180	165	150	125													
125# FLANGES THREADS 14"-24	2	AL26	150	150	135	125	110	100	125													
	22	B62	200	200	190	180	165	150														
150# FLANGES SWE. BWE THREADS	22	B61	225	225	215	205	195	180	170	160	150	140										
	22	B62	225	225	210	195	180	165	150													
	3	A216	285		260		230		200													
	6	A217	265		260		230		200													
	8	A217	290		260		230		200													
	7	A217	290		260		230		200													
	4	A217	290		260		230		200													
	9	A351	275		230		205		190													
	5	A351	275		235		215		195													
250# FLANGES THREADS	2	AL26	500	500	460	415	375	335	290	250												
	22	B62	400	400	385	365	335	300	250													
300# FLANGES SWE. BWE THREADS	22	B61	500	500	475	450	425	400	375	350	325	300										
	22	B62	500	500	465	425	390	350	315													
	3	A216	740		675		655		635													
	6	A217	695		680		655		640													
	8	A217	750		750		720		695													
	7	A217	750		750		730		705													
	4	A217	750		745		715		705													
	9	A351	720		600		540		495													
	5	A351	720		620		560		515													
600# FLANGES SWE. BWE THREADS	3	A216	1480		1350		1315		1270													
	6	A217	1390		1360		1305		1280													
	8	A217	1500		1500		1445		1385													
	7	A217	1500		1500		1455		1410													
	4	A217	1500		1490		1430		1410													
900# FLANGES SWE. BWE	3	A216	2220		2025		1970		1900													
	6	A217	2085		2035		1955		1865													
	8	A217	2250		2250		2165		2080													
	7	A217	2250		2250		2185		2115													
	4	A217	2250		2235		2150		2115													
1500# FLANGES SWE. BWE	3	A216	3705		3375		3280		3170													
	6	A217	3470		3395		3260		3200													
	8	A217	3750		3750		3610		3465													
	7	A217	3750		3750		3640		3530													
	4	A217	3750		3725		3580		3530													
2500# FLANGES SWE. BWE	3	A216	6170		5625		5470		5280													
	6	A217	5785		5660		5435		5330													
	8	A217	6250		6250		6015		5775													
	7	A217	6250		6250		6070		5880													
	4	A217	6250		6205		5965		5880													
3500# FLANGES SWE. BWE	3	A216	8640		7870		7655		7390													
	6	A217	8100		7920		7605		7250													
	8	A217	8750		8750		8420		8085													
	7	A217	8750		8750		8495		8230													
	4	A217	8750		8685		8350		8230													
4500# FLANGES SWE. BWE	3	A216	11110		10120		9845		9505													
	6	A217	10415		10185		9780		9595													
	8	A217	11250		11250		10830		10400													
	7	A217	11250		11250		10925		10585													
	4	A217	11250		11170		10740		10585													

Notes: FOR 125# ANSI CAST IRON, PRESSURE LIMIT @ 353°F, THE TEMPERATURE OF 125 PSIG STAURATED STEAM
 FOR 250# ANSI CAST IRON, PRESSURE LIMIT @ 406°F, THE TEMPERATURE OF 250 PSIG STAURATED STEAM
 FOR 400# ANSI STEEL PRESSURE/TEMPERATURE LIMITS, SEE 5/0.3.3 - 5/79 - 3R

SPENCE TYPICAL INSTALLATION FOR SANITARY STEAM SYSTEM

1. Inlet Pipe
2. Isolation Valve
3. Strainer
4. D50A Regulator
5. Bypass Pipe
6. Bypass Valve
7. Steam Scrubber Filter
8. SRV Type
9. Sanitary Steam Trap

Provide as much straight run of pipe on both sides of regulator as possible:

- 10 pipe diameters minimum to the inlet.
- 20 pipe diameters minimum of expanded line size from the outlet.

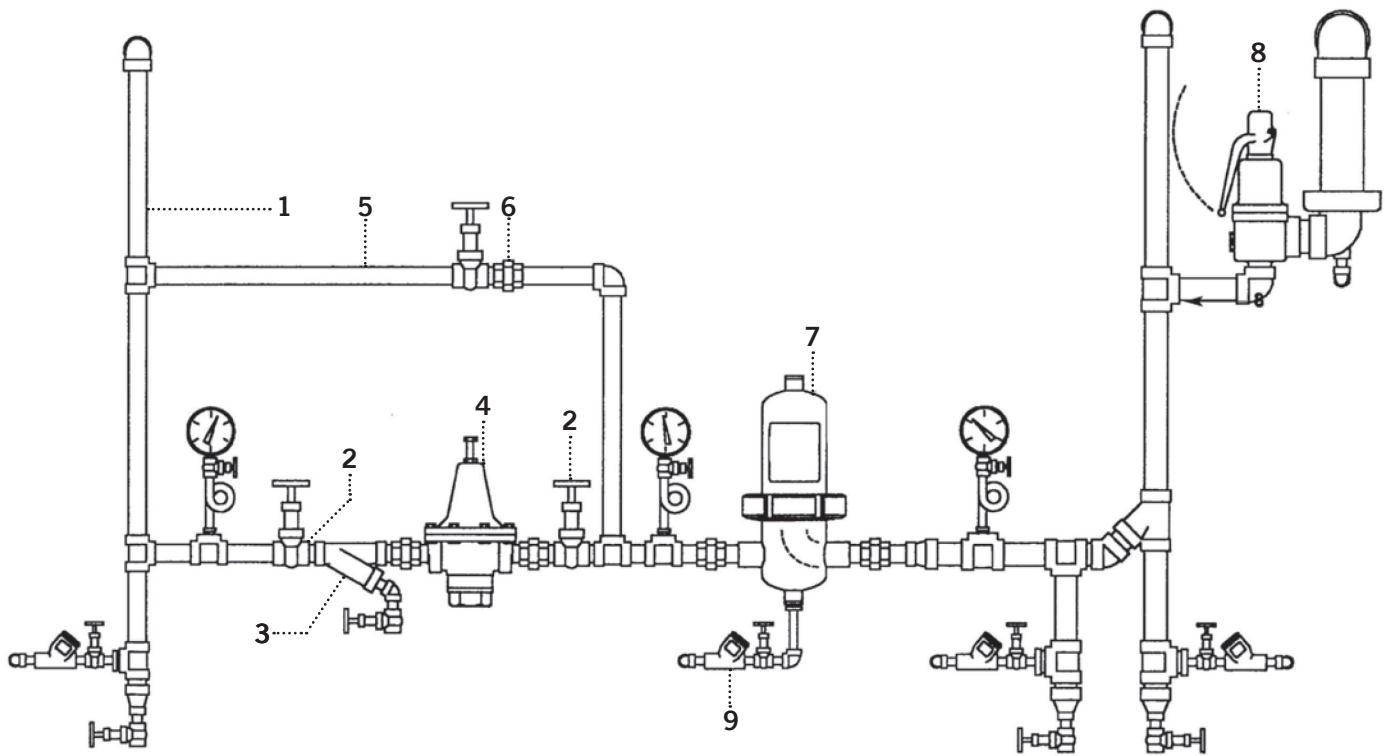

SPENCE SINGLE STAGE PRESSURE REDUCING STATION

- | | |
|--------------------|------------------------|
| 1. Inlet Pipe | 7. Delivery Pipe |
| 2. Isolation Valve | 8. SRV Type |
| 3. Strainer | 9. Drip Pan Elbow |
| 4. PRV Type | 10. Vent Stack |
| 5. Bypass Pipe | 11. Low Pressure Trap |
| 6. Bypass Valve | 12. High Pressure Trap |

Provide as much straight run of pipe on both sides of regulator as possible:

- 10 pipe diameters minimum to the inlet.
- 20 pipe diameters minimum of expanded line size from the outlet.

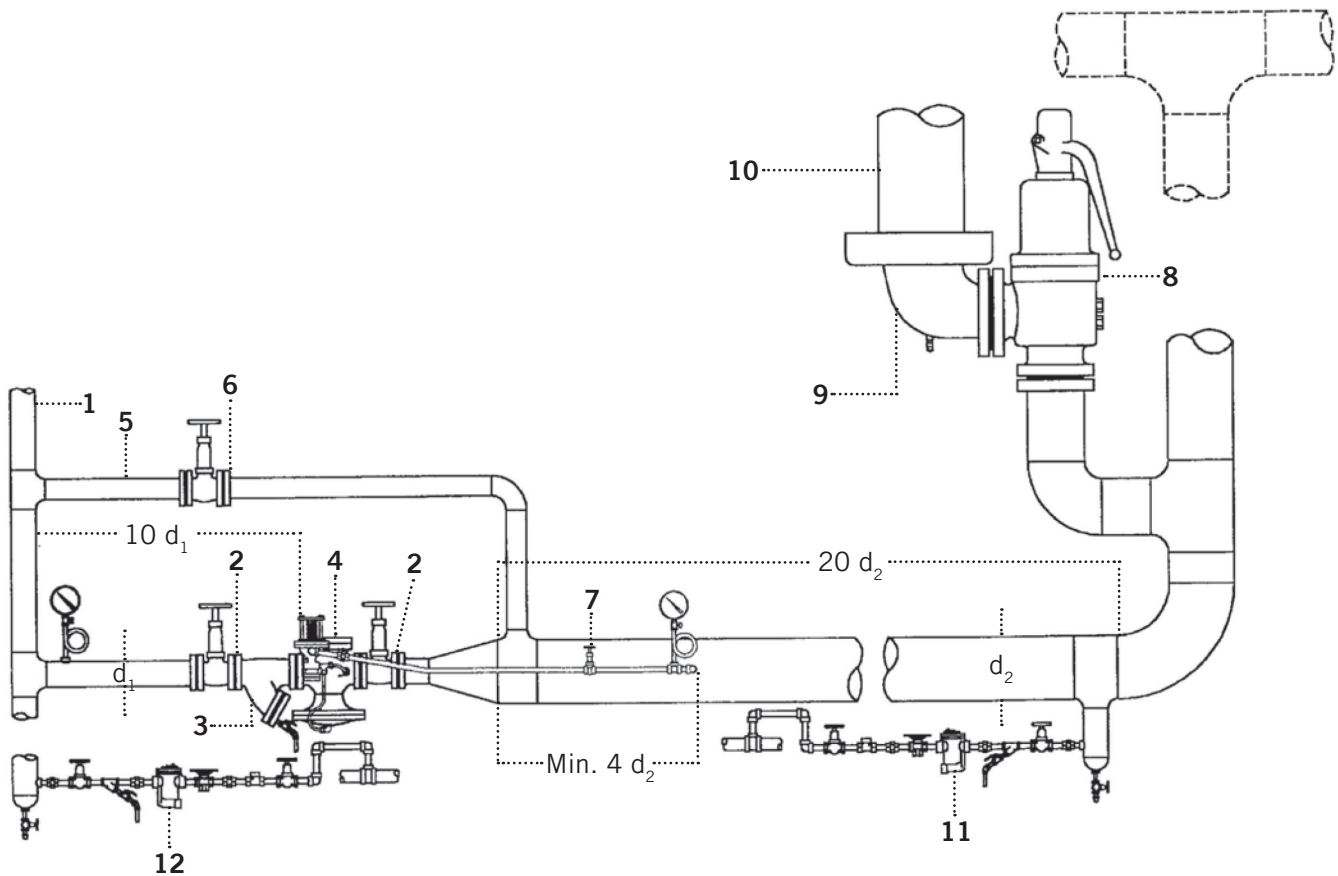

SPENCE TWO STAGE PRESSURE REDUCING STATION

- | | | |
|-------------------------------|--------------------------|------------------------|
| 1. Inlet Pipe | 8. Intermediate Pipe | 15. Delivery Pipe |
| 2. Isolation Valve | 9. Isolation Valve | 16. SRV Type |
| 3. Strainer | 10. Strainer | 17. 17. Drip Pan Elbow |
| 4. PRV Type | 11. Secondary PRV | 18. Vent Stack |
| 5. Bypass Pipe | 12. Bypass Pipe | 19. Low Pressure Trap |
| 6. High Pressure Bypass Valve | 13. Bypass Valve | |
| 7. High Pressure Trap | 14. Medium Pressure Trap | |

Provide as much straight run of pipe on both sides of regulator as possible:

- 10 pipe diameters minimum to the inlet.
- 20 pipe diameters minimum of expanded line size from the outlet.

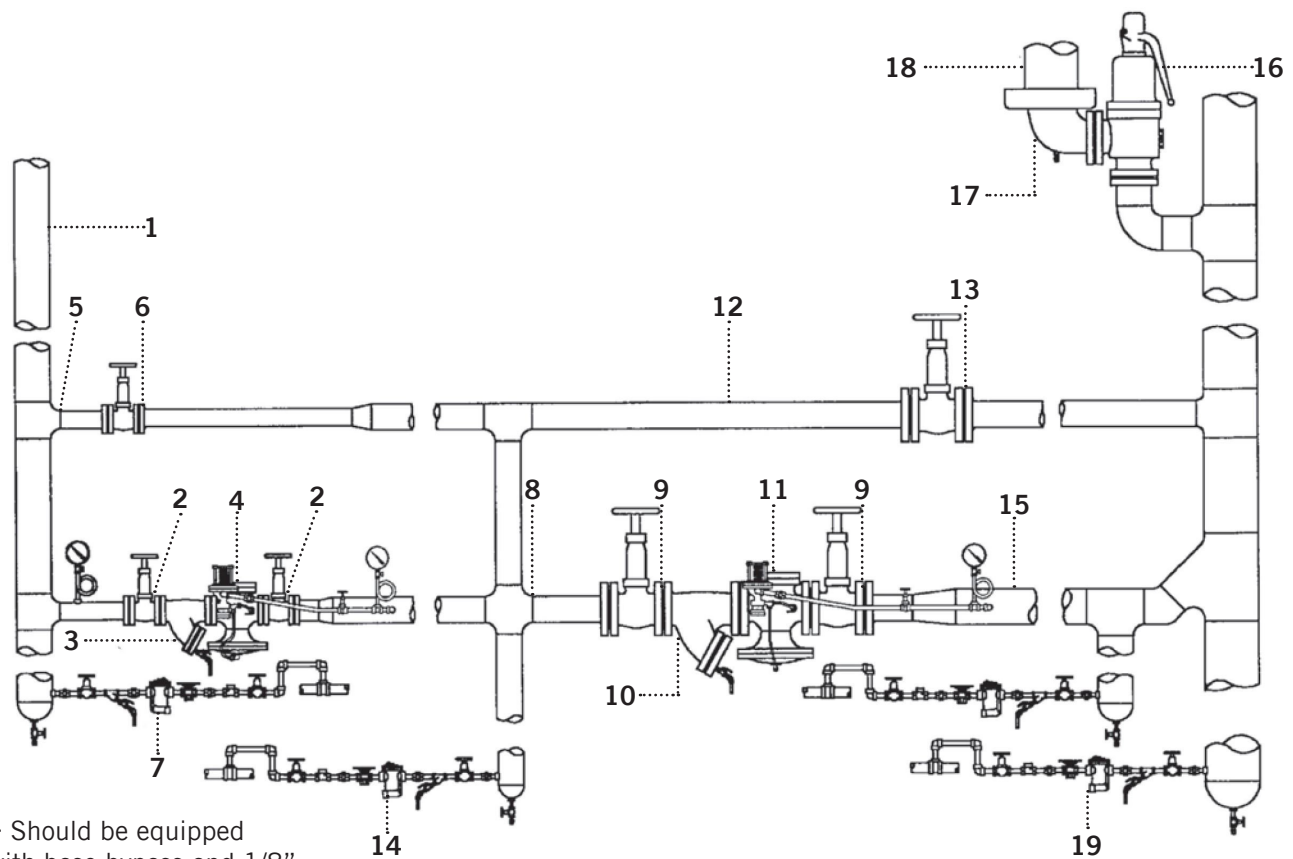

+ Should be equipped with base bypass and 1/8" bleed port.

SPENCE SINGLE STAGE PARALLEL PRESSURE REDUCING STATION

- | | |
|-----------------------|-----------------------|
| 1. Supply Pipe | 8. Intermediate Pipe |
| 2. Inlet Pipe | 9. Delivery Pipe |
| 3. Isolation Valve | 10. Discharge Pipe |
| 4. Strainer | 11. SRV Type |
| 5. PRV Type | 12. Drip Pan Elbow |
| 6. Bypass Pipe | 13. Vent Stack |
| 7. High Pressure Trap | 14. Low Pressure Trap |

Provide as much straight run of pipe on both sides of regulator as possible:

- 10 pipe diameters minimum to the inlet.
- 20 pipe diameters minimum of expanded line size from the outlet.

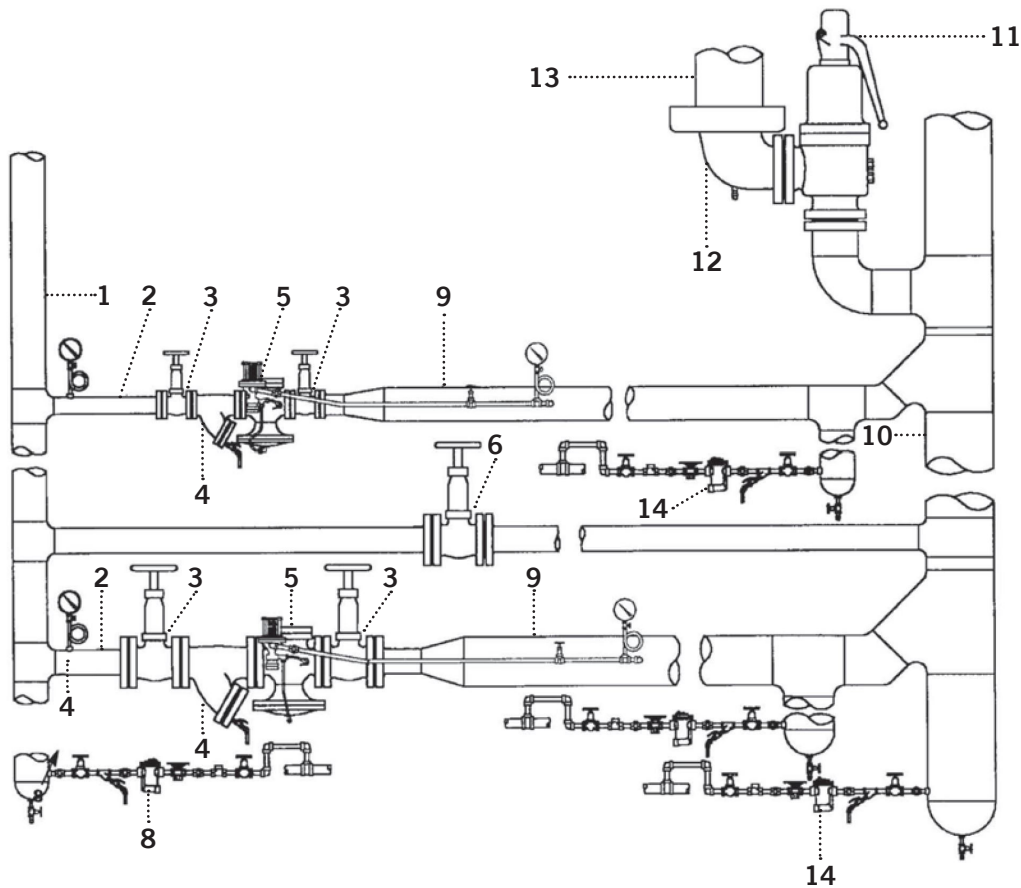

SPENCE TWO STAGE PARALLEL PRESSURE REDUCING STATION

- | | | |
|-------------------------------|-----------------------|--------------------------|
| 1. Supply Pipe | 8. High Pressure Trap | 15. Medium Pressure Trap |
| 2. Inlet Pipe | 9. Intermediate Pipe | 16. Delivery Pipe |
| 3. Isolation Valve | 10. Isolation Valve | 17. Discharge Pipe |
| 4. Strainer | 11. Strainer | 18. SRV Type |
| 5. Primary PRV+ | 12. Secondary PRV | 19. Drip Pan Elbow |
| 6. Bypass Pipe | 13. Bypass Pipe | 20. Vent Stack |
| 7. High Pressure Bypass Valve | 14. Bypass Valve | 21. Low Pressure Trap |

Provide as much straight run of pipe on both sides of regulator as possible:

- 10 pipe diameters minimum to the inlet.
- 20 pipe diameters minimum of expanded line size from the outlet.

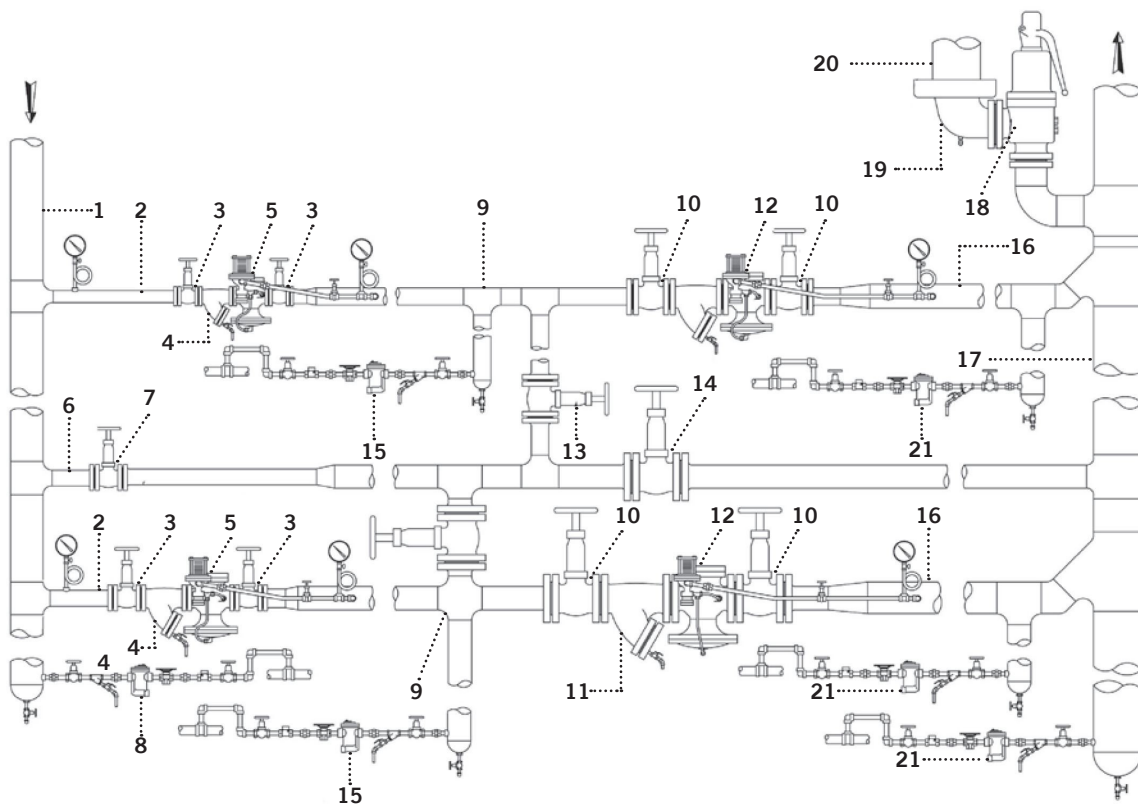

Should be equipped with base bypass and 1/8" bleed port

SPENCE TYPICAL INSTALLATION FOR INSTANTANEOUS HEATER

- | | | |
|--------------------------|------------------------|----------------------|
| 1. Inlet Pipe | 8. Thermostat | 15. Vacuum Breaker |
| 2. Isolation Valve | 9. Heat Exchanger | 16. Hot Water Outlet |
| 3. Strainer | 10. Storage Tank | |
| 4. Temperature Regulator | 11. High Pressure Trap | |
| 5. Bypass Pipe | 12. Low Pressure Trap | |
| 6. Bypass Valve | 13. Thermometer | |
| 7. Check Valve | 14. Recirculating Pump | |

Provide as much straight run of pipe on both sides of regulator as possible:

- 10 pipe diameters minimum to the inlet.
- 20 pipe diameters minimum of expanded line size from the outlet.

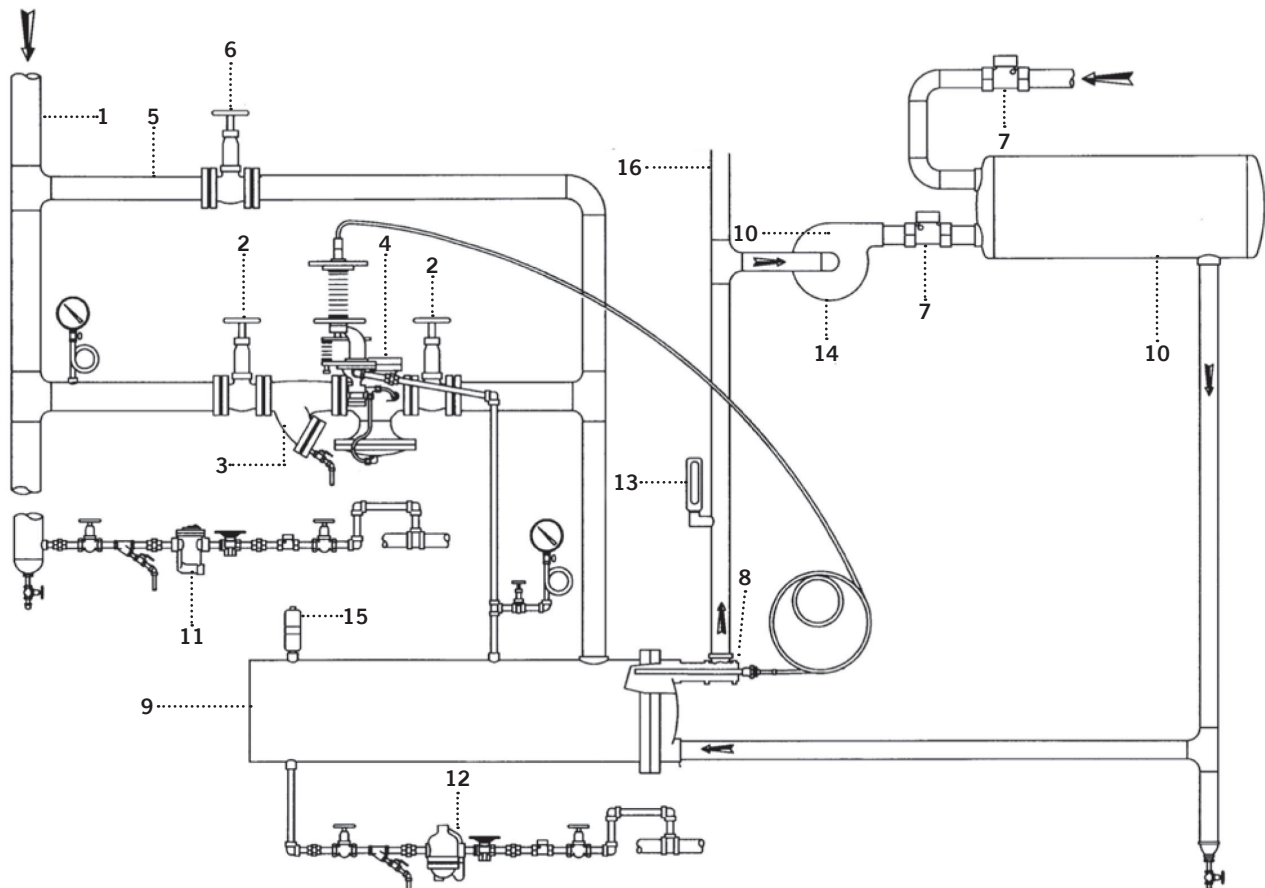

SPENCE TYPICAL INSTALLATION FOR STORAGE HEATER

- | | |
|--------------------------|------------------------|
| 1. Inlet Pipe | 7. Delivery Type |
| 2. Isolation Valve | 8. Thermostat |
| 3. Strainer | 9. Storage Heater |
| 4. Temperature Regulator | 10. Tube Budle |
| 5. Bypass Pipe | 11. High Pressure Trap |
| 6. Bypass Valve | 12. Low Pressure Trap |

Provide as much straight run of pipe on both sides of regulator as possible:

- 10 pipe diameters minimum to the inlet.
- 20 pipe diameters minimum of expanded line size from the outlet.

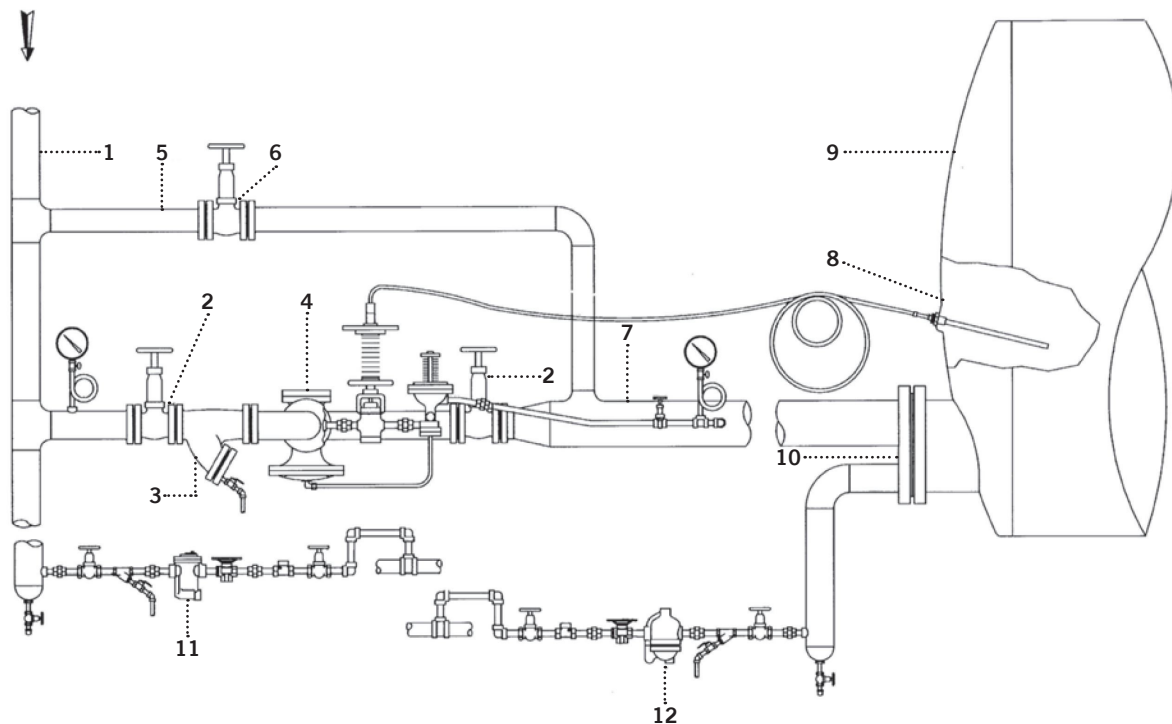

STEAM TABLE*

h = Total heat of steam, Btu per pound
 v = Specific volume, cubic feet per pound

Pres- sure psi (gage)	Tempe- rature F° (sat.)		Satur- ated Liquid	Satur- ated Vapor	TOTAL TEMPERATURE, °F																
					220	240	260	280	300	320	340	360	380	400	420	440	460				
0	212	h	180.1	1150.4	1154.4	1164.2	1173.8	1183.3	1192.8	1202.3	1211.7	1221.1	1230.5	1239.9	1249.3	1258.8	1268.2				
		v	0.0167	26.80	27.15	28.00	28.85	29.70	30.53	31.37	32.20	33.03	33.85	34.68	35.50	36.32	37.14				
5	228	h	196.2	1156.3		1162.3	1172.2	1182.0	1191.6	1201.2	1210.8	1220.3	1229.7	1239.2	1248.7	1258.2	1267.6				
		v	0.0168	20.089		20.48	21.11	21.74	22.36	22.98	23.60	24.21	24.82	25.43	26.04	26.65	27.25				
10	240	h	208.4	1160.6			1170.7	1180.6	1190.5	1200.2	1209.8	1219.4	1229.0	1238.5	1248.1	1257.6	1267.1				
		v	0.0169	16.303			16.819	17.330	17.836	18.337	18.834	19.329	19.821	20.31	20.80	21.29	21.77				
15	250	h	218.8	1164.1			1169.1	1179.3	1189.3	1199.1	1208.9	1218.6	1228.3	1237.9	1247.5	1257.0	1266.6				
		v	0.0170	13.746			13.957	14.390	14.816	15.238	15.657	16.072	16.485	16.897	17.306	17.714	18.121				
20	259	h	227.9	1167.1			1167.5	1177.9	1188.1	1198.1	1208.0	1217.8	1227.5	1237.2	1246.8	1256.4	1266.1				
		v	0.0171	11.898			11.911	12.288	12.659	13.025	13.387	13.746	14.103	14.457	14.810	15.162	15.512				
25	267	h	236.0	1169.7				1176.5	1186.8	1197.0	1207.0	1216.9	1226.7	1236.5	1246.2	1255.9	1265.5				
		v	0.0171	10.498				10.711	11.040	11.364	11.684	12.001	12.315	12.628	12.938	13.247	13.555				
30	274	h	243.4	1172.0				1175.0	1185.6	1195.9	1206.0	1216.0	1225.9	1235.8	1245.6	1255.3	1265.0				
		v	0.0172	9.401				9.484	9.781	10.072	10.359	10.643	10.925	11.204	11.482	11.758	12.033				
40	287	h	256.3	1175.9					1183.0	1193.6	1204.0	1214.3	1224.4	1234.3	1244.3	1254.1	1263.9				
		v	0.0173	7.787					7.947	8.192	8.432	8.668	8.902	9.134	9.364	9.592	9.819				
50	298	h	267.5	1179.1					1180.3	1191.3	1202.0	1212.5	1222.7	1232.9	1242.9	1252.9	1262.8				
		v	0.0174	6.655					6.676	6.889	7.096	7.300	7.501	7.700	7.896	8.091	8.285				
60	308	h	277.4	1181.9						1188.9	1199.9	1210.6	1221.1	1231.4	1241.6	1251.7	1261.7				
		v	0.0175	5.816						5.9321	6.116	6.296	6.473	6.648	6.820	6.991	7.161				
70	316	h	286.4	1184.2						1186.4	1197.7	1208.7	1219.4	1229.9	1240.2	1250.4	1260.6				
		v	0.0176	5.168						5.200	5.366	5.528	5.687	5.843	5.997	6.150	6.301				
80	324	h	294.6	1186.2							1195.5	1206.7	1217.7	1228.3	1238.8	1249.2	1259.4				
		v	0.0177	4.652							4.773	4.921	5.065	5.207	5.347	5.485	5.621				
90	331	h	302.1	1188.1							1193.2	1204.7	1215.9	1226.7	1237.4	1247.9	1258.2				
		v	0.0178	4.232							4.292	4.429	4.562	4.693	4.821	4.947	5.071				
100	338	h	309.1	1189.7							1190.8	1202.7	1214.1	1225.2	1236.0	1246.6	1257.1				
		v	0.0178	3.882							3.895	4.022	4.146	4.267	4.385	4.502	4.617				
125	353	h	324.8	1193.0								1197.3	1209.4	1221.1	1232.3	1243.3	1254.1				
		v	0.0180	3.220									3.258	3.365	3.468	3.569	3.667	3.764			
150	366	h	338.5	1195.6									1204.5	1216.7	1228.4	1239.8	1251.0				
		v	0.0182	2.752										2.818	2.910	2.998	3.085	3.169			
175	378	h	350.8	1197.6									1199.3	1212.2	1224.5	1236.3	1247.8				
		v	0.0183	2.404										2.414	2.498	2.577	2.655	2.730			
200	388	h	361.9	1199.3										1207.4	1220.3	1232.6	1244.5				
		v	0.0185	2.134											2.180	2.253	2.324	2.393			
225	397	h	372.1	1200.6											1202.5	1216.0	1228.8	1241.1			
		v	0.0186	1.9183												1.9276	1.9964	2.062	2.126		
250	406	h	381.6	1201.7												1211.5	1224.9	1237.6			
		v	0.0187	1.7422													1.7870	1.8488	1.9081		
275	414	h	390.5	1202.6													1206.8	1220.8	1234.0		
		v	0.0188	1.5954														1.6130	1.6717	1.7277	
300	422	h	398.8	1203.2															1216.5	1230.3	
		v	0.0190	1.4711																1.5222	1.5755
350	436	h	414.1	1204.1																1207.5	1222.4
		v	0.0192	1.2720																	1.2831
400	448	h	428.1	1204.6																	1214.0
		v	0.0194	1.1194																	
450	460	h	440.9	1204.6																	
		v	0.0196	0.9985																	
500	470	h	452.9	1204.2																	
		v	0.0198	0.9004																	
550	480	h	464.1	1203.7																	
		v	0.0200	0.8191																	
600	489	h	474.7	1203.0																	
		v	0.0202	0.7503																	

*Adapted with permission from "Thermodynamic Properties of Steam", Keenan and Keyes, published by John Wiley & Sons, Inc.

STEAM TABLE*

h = Total heat of steam, Btu per pound
v = Specific volume, cubic feet per pound

TOTAL TEMPERATURE, °F															Temperature F° (sat.)	Pressure psi (gage)	
480	500	520	540	560	580	600	620	640	660	680	700	720	740	750			
1277.6	1287.1	1296.6	1306.2	1315.7	1325.3	1334.8	1344.5	1354.2	1363.8	1373.5	1383.2	1393.0	1402.8	1407.7	h	212	0
37.96	38.78	39.60	40.41	41.23	42.04	42.86	43.68	44.49	45.31	46.12	46.94	47.75	48.56	48.97	v		
1277.1	1286.6	1296.2	1305.7	1315.3	1324.8	1334.4	1344.1	1353.8	1363.5	1373.2	1382.9	1392.7	1402.6	1407.5	h	228	5
27.86	28.46	29.06	29.67	30.27	30.87	31.47	32.07	32.67	33.27	33.87	34.47	35.07	35.67	35.96	v		
1276.6	1286.2	1295.8	1305.3	1314.9	1324.5	1334.1	1343.8	1353.5	1363.2	1372.9	1382.6	1392.5	1402.3	1407.2	h	240	10
22.26	22.74	23.22	23.71	24.19	24.68	25.16	25.64	26.12	26.60	27.08	27.56	28.04	28.52	28.76	v		
1276.2	1285.7	1295.3	1304.9	1314.5	1324.2	1333.8	1343.5	1353.2	1362.9	1372.6	1382.4	1392.3	1402.1	1407.0	h	250	15
18.528	18.933	19.337	19.741	20.144	20.547	20.95	21.35	21.75	22.15	22.56	22.96	23.36	23.76	23.96	v		
1275.7	1285.3	1294.9	1304.5	1314.1	1323.8	1333.5	1343.2	1352.9	1362.6	1372.3	1382.1	1391.9	1401.8	1406.7	h	259	20
15.862	16.210	16.558	16.905	17.251	17.597	17.943	18.288	18.633	18.977	19.322	19.666	20.01	20.35	20.52	v		
1275.2	1284.8	1294.5	1304.1	1313.8	1323.4	1333.1	1342.8	1352.5	1362.3	1372.1	1381.9	1391.7	1401.6	1406.5	h	267	25
13.862	14.168	14.473	14.778	15.082	15.385	15.688	15.990	16.293	16.595	16.896	17.198	17.499	17.801	7.951	v		
1274.7	1284.4	1294.0	1303.7	1313.4	1323.1	1332.8	1342.5	1352.2	1362.0	1371.8	1381.6	1391.5	1401.4	1406.3	h	274	30
12.307	12.580	12.852	13.123	13.394	13.665	13.935	14.204	14.473	14.742	15.011	15.279	15.547	15.815	15.949	v		
1273.7	1283.4	1293.2	1302.9	1312.6	1322.4	1332.1	1341.9	1351.7	1361.5	1371.3	1381.1	1391.0	1400.9	1405.8	h	287	40
10.044	10.269	10.493	10.717	10.940	11.162	11.384	11.605	11.826	12.047	12.268	12.488	12.708	12.927	13.037	v		
1272.7	1282.5	1292.3	1302.1	1311.9	1321.7	1331.5	1341.3	1351.1	1360.9	1370.8	1380.6	1390.5	1400.4	1405.4	h	298	50
8.478	8.670	8.861	9.051	9.240	9.429	9.618	9.806	9.993	10.181	10.368	10.555	10.741	10.928	11.021	v		
1271.6	1281.5	1291.4	1301.3	1311.1	1321.0	1330.8	1340.6	1350.5	1360.3	1370.2	1380.1	1390.0	1399.9	1404.9	h	308	60
7.329	7.496	7.663	7.829	7.994	8.159	8.323	8.486	8.649	8.812	8.975	9.138	9.300	9.462	9.543	v		
1270.6	1280.6	1290.5	1300.5	1310.4	1320.2	1330.1	1340.0	1349.9	1359.8	1369.7	1379.6	1389.6	1399.5	1404.5	h	316	70
6.450	6.599	6.747	6.894	7.041	7.187	7.332	7.477	7.622	7.766	7.910	8.054	8.198	8.341	8.413	v		
1269.5	1279.6	1289.6	1299.6	1309.6	1319.5	1329.4	1339.4	1349.3	1359.3	1369.2	1379.1	1389.1	1399.0	1404.0	h	324	80
5.756	5.891	6.024	6.156	6.288	6.419	6.550	6.680	6.810	6.940	7.069	7.199	7.327	7.456	7.520	v		
1268.5	1278.6	1288.7	1298.8	1308.8	1318.8	1328.7	1338.7	1348.7	1358.6	1368.6	1378.5	1388.5	1398.5	1403.5	h	331	90
5.195	5.317	5.439	5.559	5.679	5.799	5.918	6.036	6.154	6.272	6.389	6.506	6.623	6.740	6.798	v		
1267.4	1277.7	1287.8	1297.9	1308.0	1318.0	1328.1	1338.1	1348.0	1358.0	1368.0	1378.0	1388.1	1398.1	1403.1	h	338	100
4.730	4.843	4.955	5.066	5.176	5.285	5.394	5.503	5.611	5.719	5.827	5.934	6.041	6.148	6.201	v		
1266.4	1276.2	1286.1	1296.0	1306.0	1316.2	1326.4	1336.5	1346.6	1356.6	1366.7	1376.8	1386.9	1397.0	1402.0	h	353	125
3.860	3.954	4.047	4.140	4.232	4.323	4.413	4.503	4.593	4.683	4.772	4.861	4.949	5.038	5.082	v		
1261.9	1272.6	1283.2	1293.6	1304.0	1314.3	1324.6	1334.8	1345.0	1355.2	1365.3	1375.4	1385.6	1395.8	1400.8	h	366	150
3.252	3.334	3.414	3.494	3.573	3.652	3.730	3.807	3.884	3.960	4.037	4.113	4.188	4.264	4.301	v		
1259.0	1270.0	1280.8	1291.4	1302.0	1312.4	1322.8	1333.2	1343.5	1353.7	1363.9	1374.2	1384.4	1394.6	1399.7	h	378	175
2.804	2.877	2.948	3.019	3.089	3.157	3.226	3.294	3.361	3.429	3.495	3.562	3.628	3.694	3.727	v		
1256.0	1267.3	1278.3	1289.2	1299.9	1310.5	1321.0	1331.4	1341.8	1352.2	1362.5	1372.8	1383.1	1393.3	1398.5	h	388	200
2.460	2.525	2.590	2.653	2.716	2.777	2.839	2.900	2.960	3.019	3.079	3.139	3.198	3.256	3.286	v		
1253.0	1264.5	1275.8	1286.9	1297.8	1308.5	1319.2	1329.8	1340.3	1350.7	1361.1	1371.5	1381.9	1392.2	1397.3	h	397	225
2.187	2.247	2.306	2.364	2.421	2.477	2.533	2.587	2.642	2.696	2.750	2.804	2.857	2.910	2.936	v		
1249.9	1261.7	1273.2	1284.5	1295.6	1306.5	1317.3	1328.0	1338.7	1349.2	1359.7	1370.2	1380.6	1391.0	1396.2	h	406	250
1.9654	2.021	2.076	2.129	2.181	2.233	2.284	2.334	2.384	2.434	2.483	2.532	2.580	2.629	2.653	v		
1246.6	1258.8	1270.6	1282.1	1293.4	1304.5	1315.5	1326.3	1337.0	1347.7	1358.3	1368.8	1379.3	1389.8	1395.0	h	414	275
1.7816	1.8338	1.8846	1.9342	1.9829	2.031	2.078	2.125	2.171	2.217	2.262	2.307	2.352	2.396	2.418	v		
1243.3	1255.8	1267.9	1279.7	1291.2	1302.5	1313.6	1324.5	1335.4	1346.1	1356.8	1367.4	1378.0	1388.6	1393.8	h	422	300
1.6266	1.6759	1.7237	1.7703	1.8159	1.8607	1.9048	1.9483	1.9912	2.034	2.076	2.118	2.159	2.200	2.220	v		
1236.4	1249.6	1262.4	1274.7	1286.6	1298.2	1309.7	1320.9	1332.0	1343.0	1353.9	1364.7	1375.4	1386.1	1391.4	h	436	350
1.3795	1.4243	1.4675	1.5094	1.5501	1.5900	1.6291	1.6676	1.7056	1.7430	1.7801	1.8168	1.8531	1.8892	1.9071	v		
1229.0	1243.2	1256.6	1269.4	1281.8	1293.9	1305.7	1317.2	1328.6	1339.8	1350.9	1361.9	1372.8	1383.6	1389.0	h	448	400
1.1908	1.2325	1.2724	1.3108	1.3480	1.3842	1.4196	1.4544	1.4885	1.5222	1.5554	1.5883	1.6207	1.6529	1.6689	v		
1221.2	1236.3	1250.5	1264.0	1276.9	1289.4	1301.6	1313.5	1325.1	1336.5	1347.8	1359.0	1370.1	1381.1	1386.5	h	460	450
1.0416	1.0811	1.1186	1.1544	1.1889	1.2224	1.2550	1.2868	1.3180	1.3488	1.3789	1.4088	1.4382	1.4675	1.4819	v		
1212.8	1229.0	1244.0	1258.3	1271.8	1284.8	1297.3	1309.6	1321.5	1333.2	1344.7	1356.1	1367.3	1378.4	1384.0	h	470	500
0.9204	0.9584	0.9941	1.0280	1.0604	1.0917	1.1221	1.1516	1.1805	1.2088	1.2367	1.2641	1.2913	1.3180	1.3313	v		
	1221.4	1237.4	1252.4	1266.5	1280.0	1293.0	1305.6	1317.8	1329.8	1341.6	1353.2	1364.6	1375.8	1381.4	h	480	550
	0.8565	0.8909	0.9234	0.9542	0.9838	1.0124	1.0401	1.0671	1.0935	1.1195	1.1449	1.1700	1.1947	1.2070	v		
	1213.2	1230.3	1246.1	1261.0	1275.1	1288.5	1301.5	1314.1	1326.3	1338.3	1350.2	1361.8	1373.2	1378.9	h	489	600
	0.7703	0.8040	0.8353	0.8649	0.8931	0.9203	0.9465	0.9720	0.9968	1.0211	1.0450	1.0684	1.0916	1.1030	v		

*Adapted with permission from "Thermodynamic Properties of Steam", Keenan and Keyes, published by John Wiley & Sons, Inc.



All the information in this Spence Designer's Guide
can be found on www.SpenceValve.com.

Emerson

Americas

McKinney, Texas 75069 USA
T +1 972 548 3574

Europe

T +39 051 419 0611

Asia Pacific

T +65 6777 8211

Middle East / Africa

T +971 4811 8100

 www.SpenceValve.com

